

PALM BEACH COUNTY TRAFFIC SIGNAL INSTALLATION STANDARDS AND DETAILS 2022

TYPICAL NO.

- T-1 COVER - TABLE OF CONTENTS
- T-2 NOTE
- T-3 BLANK
- T-4 STANDARD SYMBOLS
- T-5 TYPICAL SPAN SIGNAL OPERATION INSTALLATION
- T-5.1 TYPICAL FYA OPERATION AND INSTALLATION
- T-5.2 CABLES DISTRIBUTION SYSTEM FOR SPAN WIRE INSTALLATION
- T-5.3 CONCRETE SERVICE POLE DETAILS FOR SPAN WIRE
- T-5.4 CONCRETE POLE, TYPICAL GUY, CLEAR ZONE DETAIL, STANDARD LUMINAIRE DETAIL
- T-5.5 SPAN WIRE DISCONNECT WIRING DIAGRAM PER SIGNAL HEAD
- T-5.6 MODIFICATION TO SPAN WIRE INSTALLATION DETAIL OF FDOT STANDARD INDEX 17727
- T-5.7 DISCONNECT WITH DOUBLE DRIP LOOP SIGNAL HEAD
- T-6 TYPICAL MAST ARM SIGNAL OPERATION AND INSTALLATION
- T-6.1 CABLE DISTRIBUTION SYSTEM FOR MAST ARM INSTALLATION

INDEX OF SHEETS

- T-6.2 SERVICE DISCONNECT/BREAKER ASSEMBLY, STUB POLE DETAIL, MAST ARM ASSEMBLY INSTALLATION
- T-6.3 POWER SOURCE METER AND BREAKER BOX STUB POLE DETAIL
- T-7 PEDESTRIAN SIGNAL, SIGN AND EQUIPMENT INSTALLATION
- T-8 SCHOOL ZONE FLASHER DETAIL
- T-8.1 PED, RECTANGULAR RAPID BEACON & EQUESTRIAN FLASHER DETAIL
- T-9 CABINET-FOUNDATION DETAIL, TYPICAL GROUND ROD ARRAY
- T-9.1 ATX40 CABINET-FOUNDATION DETAIL, GROUND ROD ARRAY
- T-9.2 ATX32 CABINET-FOUNDATION DETAIL, GROUND ROD ARRAY
- T-10 ILLUMINATED STREET NAME SIGN DETAIL
- T-11 STOP BAR LOOPS AND ADVANCE LOOPS
- T-11.1 INDUCTANCE LOOP DETECTOR SPLICING DETAIL, LOOP LEAD-IN DETAIL, VIDEO DETECTION ZONE DETAIL
- T-12 PERMANENT COUNT STATION AND LOOP DETAIL
- T-13 BLANK
- T-14 TWO CONDUITS WITH PULL BOXES, ROUTE WITNESS MARKERS, MARKING TAPE, LOCATING WIRE AND PULL LINE (JET LINE)

| | | | | | |
|-----|------|-----------|----|------|---------------|
| | | | | | DRAWING T-1 |
| NO. | DATE | REVISIONS | BY | APP. | SHEET 1 OF 28 |

ALL NOTES

- ALL NEW PERMISSIVE AND PROTECTED/PERMISSIVE SIGNALS WILL BE FYA.

PALM BEACH COUNTY, FLORIDA
 TRAFFIC DIVISION
 SIGNAL TYPICAL

NOTE

Fatme N. Jafar
 SIGNATURE NAME DATE DATE FATMEH N. JAFAR
 ENGINEER OF RECORD
 DRAWN BY N. T. S. CONTRACT NO.
 CHECKED BY

| NO. | DATE | REVISIONS | BY | APP. |
|-----|------|-----------|----|------|
| | | | | |

THIS SHEET IS INTENTIONALLY LEFT BLANK

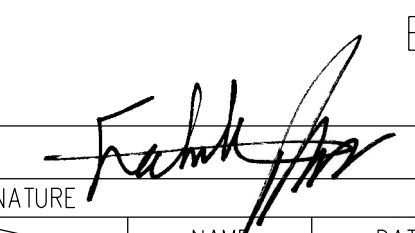
| | | | | | |
|---|--|--|--------------------|--|--|
| PALM BEACH COUNTY, FLORIDA | | | | | |
| TRAFFIC DIVISION | | | | | |
| SIGNAL TYPICAL | | | | | |
| BLANK | | | | | |
| SIGNATURE  | | | DATE | | |
| DRAWN BY | | | ENGINEER OF RECORD | | |
| CHECKED BY | | | SCALE | | |
| | | | N. T. S. | | |
| | | | CONTRACT NO. | | |

| NO. | DATE | REVISIONS | BY | APP. |
|-----|------|-----------|----|------|
| | | | | |

SYMBOL LEGEND

- | | |
|---|--|
| <ul style="list-style-type: none"> CONCRETE POLE CONCRETE POLE WITH PEDESTRIAN DETECTOR CONCRETE POLE WITH PEDESTRIAN SIGNAL HEAD CONCRETE POLE WITH PEDESTRIAN DETECTOR & PEDESTRIAN SIGNAL HEAD LUMINAIRE ON CONCRETE POLE WOOD POLE LUMINAIRE ON WOOD POLE WOOD POLE WITH PEDESTRIAN DETECTOR WOOD POLE WITH PEDESTRIAN DETECTOR & PEDESTRIAN SIGNAL HEAD PEDESTRIAN DETECTOR ON ALUMINUM POST ALUMINUM PEDESTAL PEDESTAL WITH PEDESTRIAN DETECTOR PEDESTAL WITH PEDESTRIAN DETECTOR & PEDESTRIAN SIGNAL HEAD CONTROLLER CABINET | <ul style="list-style-type: none"> 3-SECTION/4-SECTION SIGNAL HEAD & 3-SECTION/4-SECTION FYA SIGNAL HEAD 5-SECTION SIGNAL HEAD OVERHEAD SIGN GROUND MOUNTED SIGN AUDIBLE PEDESTRIAN DETECTOR MAST ARM MAST ARM WITH PEDESTRIAN DETECTOR MAST ARM WITH PEDESTRIAN SIGNAL HEAD MAST ARM WITH PEDESTRIAN DETECTOR & PEDESTRIAN SIGNAL HEAD VIDEO DETECTION CAMERA CONCRETE STUB POLE PULL BOX 17"x30"x12" PULL BOX 17"x30"x24" PULL BOX 30"x48"x24" SCHOOL ZONE FLASHER ON POST SCHOOL ZONE FLASHER ON OVERHEAD |
|---|--|

GENERAL NOTES:
 1. THIS DRAWING IS NOT TO SCALE.
 2. DESIGN, LAYOUT & DATA ON THIS SHEET ARE FOR ILLUSTRATION PURPOSE ONLY.

PALM BEACH COUNTY, FLORIDA
 TRAFFIC DIVISION
 SIGNAL TYPICAL

STANDARD SYMBOLS

| | | | | |
|------------|---------------------------------------|------|-------|--------------|
| | FATMEH N. JAFAR ENGINEER OF RECORD | | | |
| DRAWN BY | NAME | DATE | SCALE | CONTRACT NO. |
| CHECKED BY | | | | N. T. S. |

| NO. | DATE | REVISIONS | BY | APP. |
|-----|------|-----------|----|------|
| | | | | |

ASSOCIATED PHASE MOVEMENTS

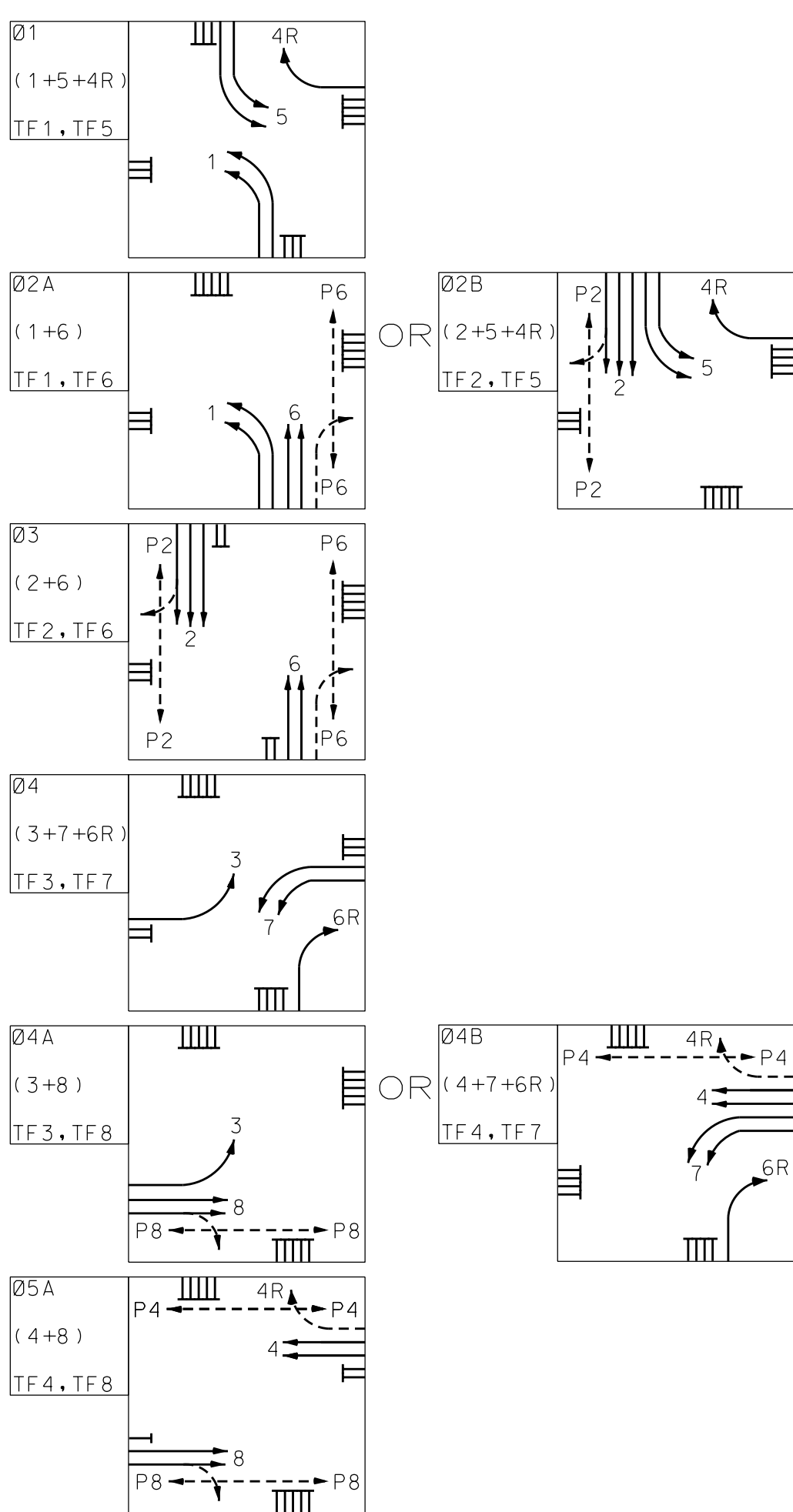

DETAIL OF SIGNAL HEADS

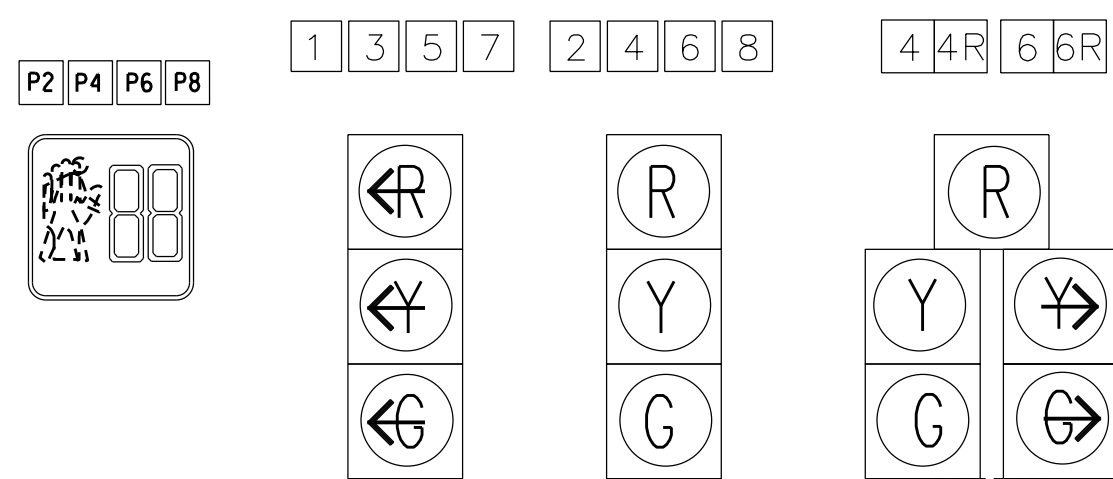

DESIGN NOTES: 1. LUMINAIRE LOCATIONS: NE, NW, SE, SW (PBC)
 2. FLASHING OPERATION: YELLOW --- 2 AND 6, RED ----- 1, 3, 4, 5, 7, AND 8
 3. SPEED LIMITS: MAJOR BOULEVARD - 45 MPH, MINOR ROAD - 45 MPH

DETAIL OF SIGNS

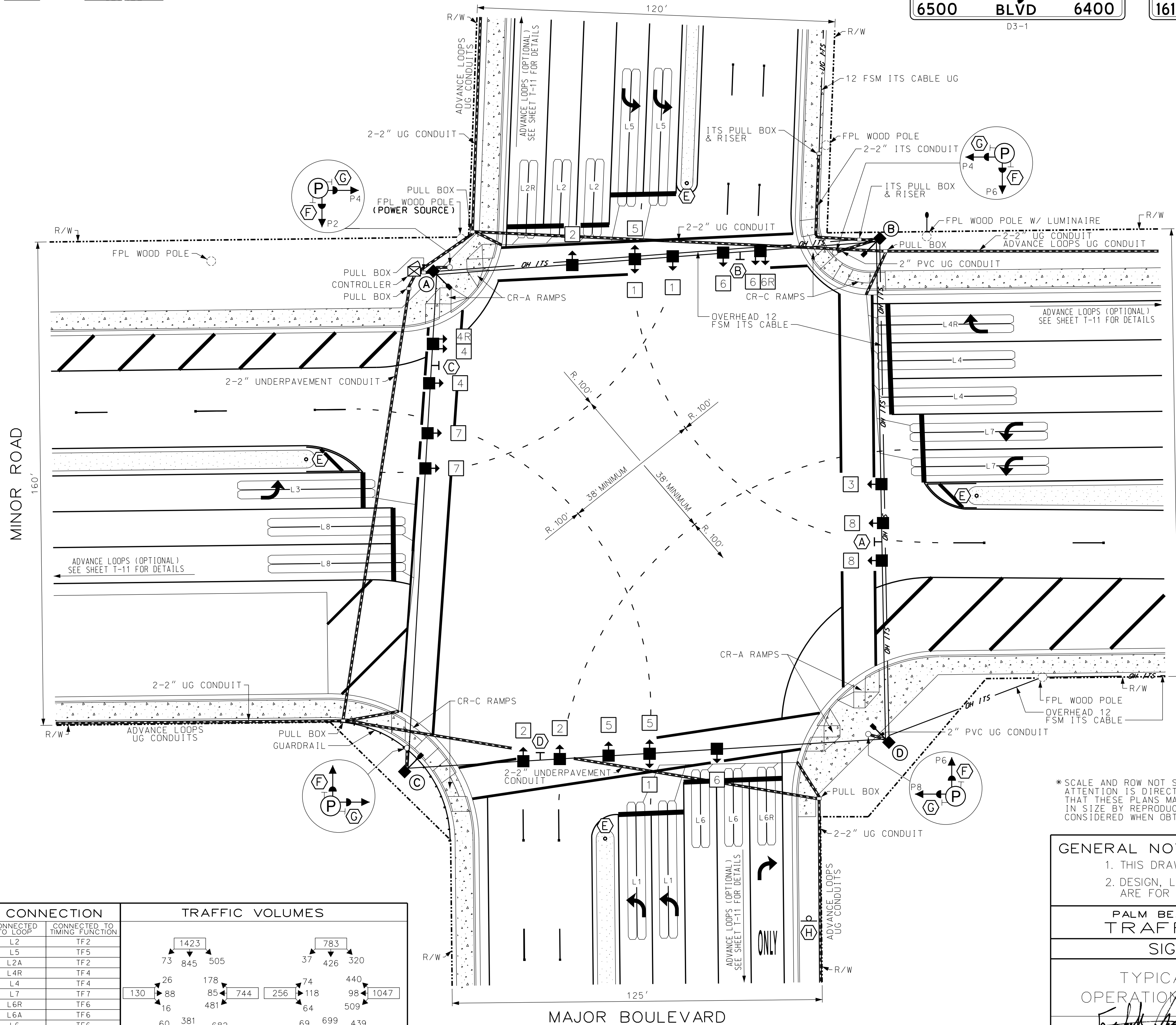
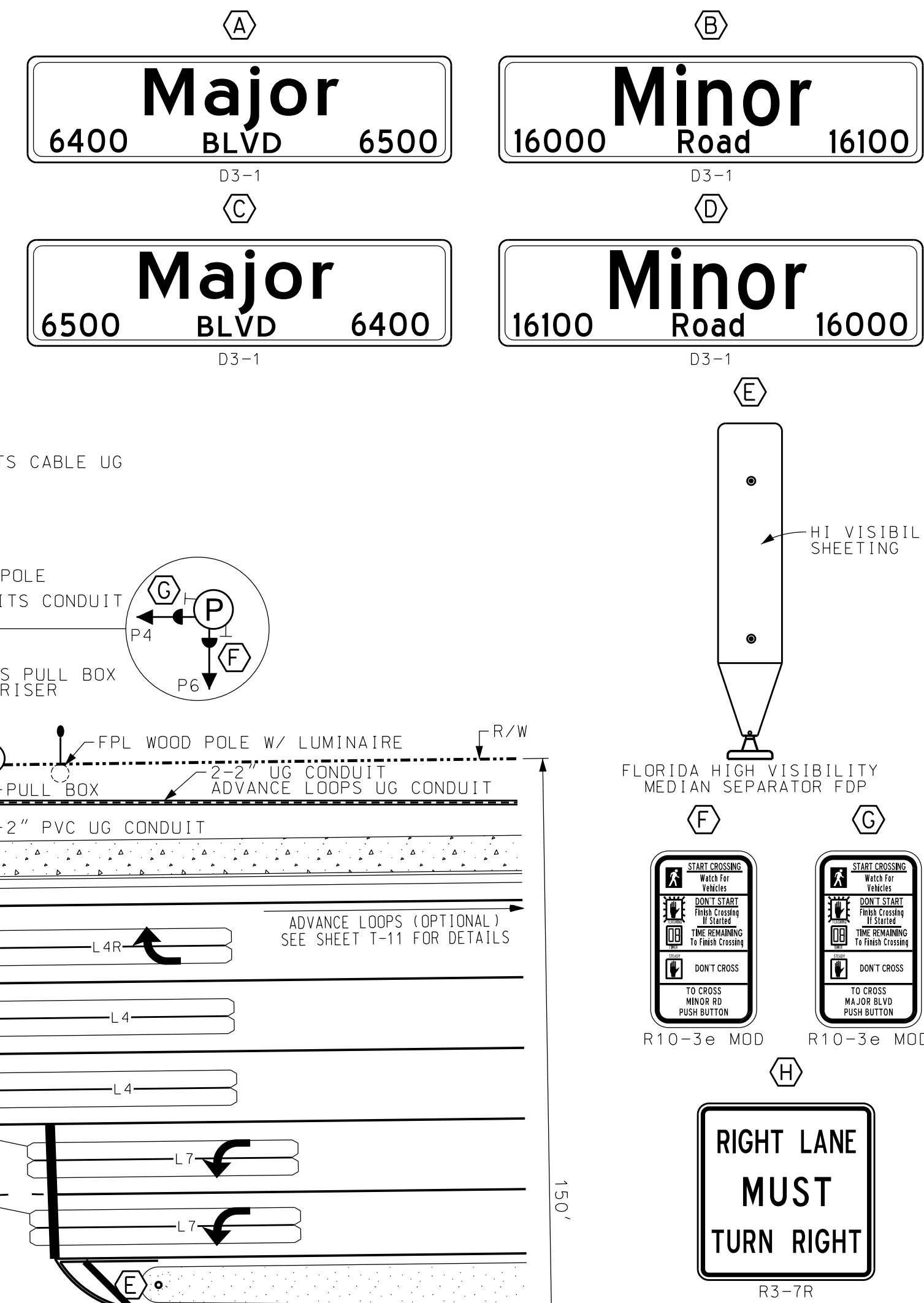

*(A,B,D & E) REFER TO SHEET T-5.3 (CONCRETE POLE DETAIL)

| POLE TABULATION | | | | | | | | | | | |
|-----------------|----------------------------------|----------------------------------|------|-------------------|-------------------------------------|-------------------------------------|----------------------------|------|-------|----------------------------|--------------------------|
| POLE I.D. | UPPER TIE-INTO TOP OF POLE * (A) | LOWER TIE-INTO TOP OF POLE * (B) | SPAN | POLE LENGTH * (D) | UPPER TIE-INTO GROUND LEVEL (D-E-A) | LOWER TIE-INTO GROUND LEVEL (D-E-B) | LOWER TIE-INTO CROWN LEVEL | TYPE | CLASS | ROAD-CROWN TO GROUND LEVEL | DEPTH BELOW GROUND * (E) |
| A | 4' | 14' | 161' | 46' | 33' | 23' | 23' | CONC | VII | 0' | 9' |
| B | 4' | 14' | 166' | 46' | 33' | 23' | 23' | CONC | VII | 0' | 9' |
| C | 4' | 14' | 161' | 46' | 33' | 23' | 23' | CONC | VII | 0' | 9' |
| D | 4' | 14' | 166' | 46' | 33' | 23' | 23' | CONC | VII | 0' | 9' |

| LOOP DETECTOR CONNECTION | | | |
|--------------------------|--------------------|-------------------|------------------------------|
| DETECTOR UNIT NO. | DETECTOR OPERATION | CONNECTED TO LOOP | CONNECTED TO TIMING FUNCTION |
| 1 | DELAY/STRETCH | L2 | TF2 |
| 2 | NORMAL | L5 | TF5 |
| 3 | NORMAL | L2A | TF2 |
| 4 | DELAY/NORMAL | L4R | TF4 |
| 5 | DELAY/STRETCH | L4 | TF4 |
| 6 | NORMAL | L7 | TF7 |
| 7 | DELAY/NORMAL | L6R | TF6 |
| 8 | NORMAL | L6A | TF6 |
| 9 | DELAY/STRETCH | L6 | TF6 |
| 10 | NORMAL | L1 | TF1 |
| 11 | DELAY/STRETCH | L8 | TF8 |
| 12 | DELAY/NORMAL | L3 | DISCONNECTED |
| 13 | DELAY/NORMAL | L2R | TF2 |
| 14 | NORMAL | L3 | TF3 |

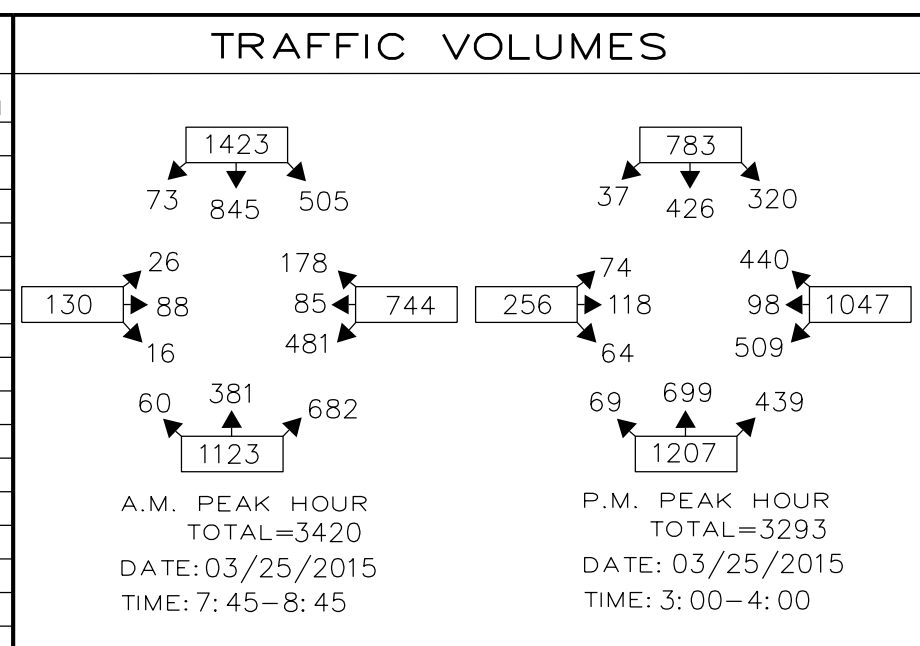

* SCALE AND ROW NOT SURVEY ACCURATE. ATTENTION IS DIRECTED TO THE FACT THAT THESE PLANS MAY HAVE BEEN ALTERED IN SIZE BY REPRODUCTION. THIS MUST BE CONSIDERED WHEN OBTAINING SCALED DATA.

GENERAL NOTES:
 1. THIS DRAWING IS NOT TO SCALE.
 2. DESIGN, LAYOUT & DATA ON THIS SHEET ARE FOR ILLUSTRATION PURPOSE ONLY.

PALM BEACH COUNTY, FLORIDA
 TRAFFIC DIVISION
 SIGNAL TYPICAL

TYPICAL SPAN SIGNAL
 OPERATION AND INSTALLATION

SIGNATURE: *Fatmeh N. Jafar* DATE: _____ FATMEH N. JAFAR ENGINEER OF RECORD
 DRAWN BY: _____ DATE: _____ SCALE: _____ CONTRACT NO. _____
 CHECKED BY: _____ * N. T. S.
 DRAWING T-5 SHEET 5 OF 28

ASSOCIATED PHASE MOVEMENTS

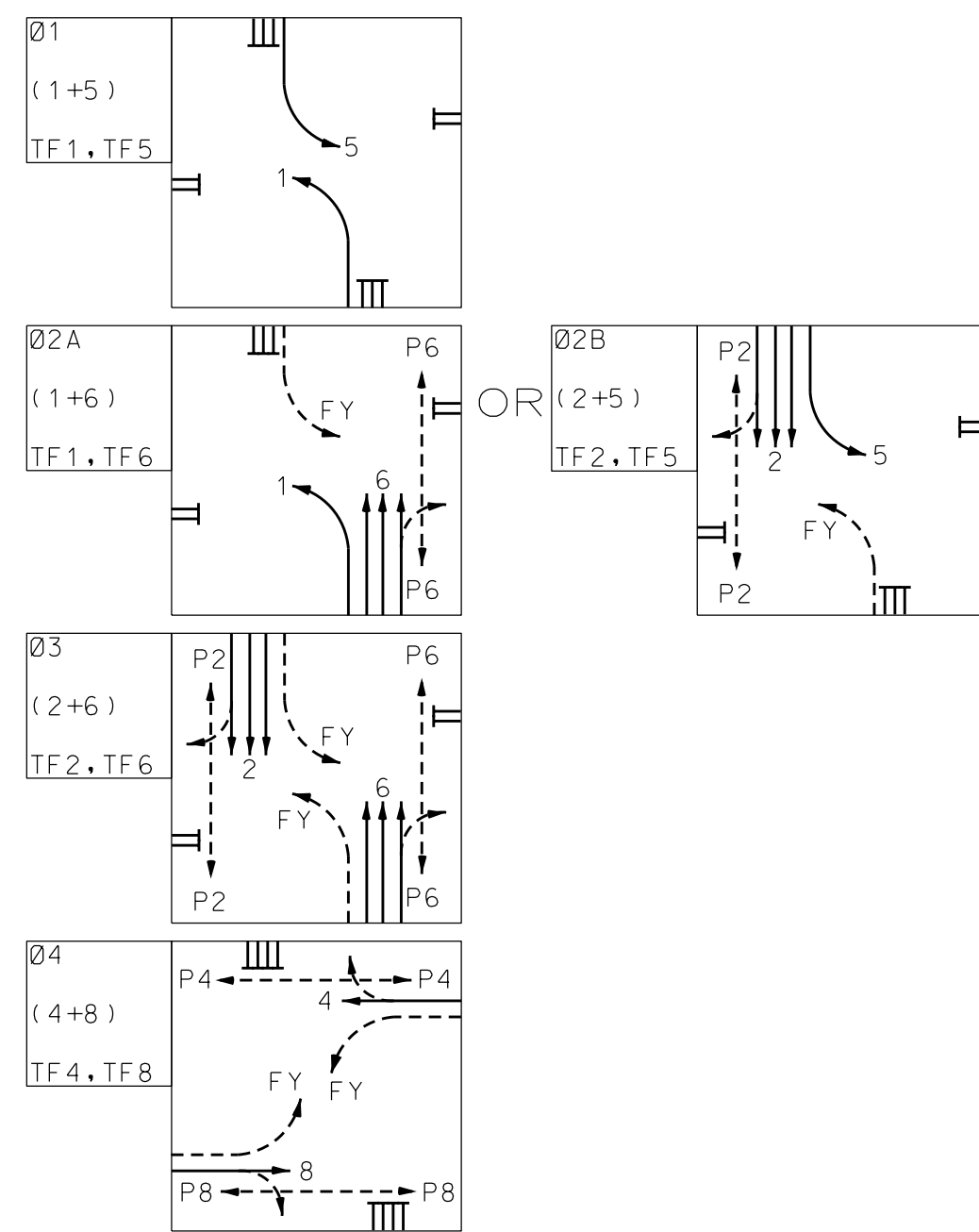

DETAIL OF SIGNAL HEADS

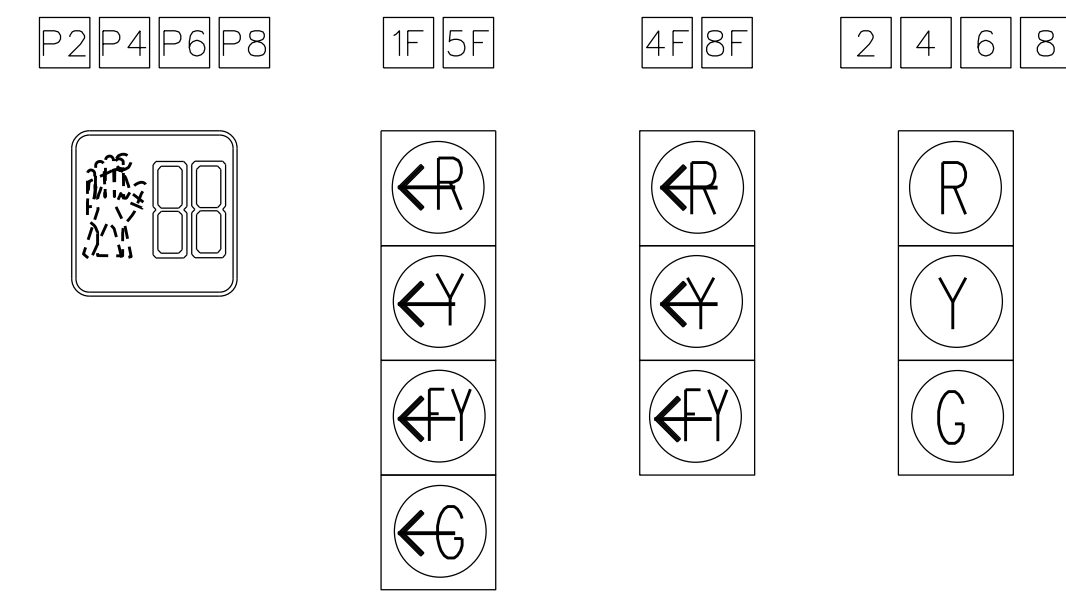

DETAIL OF SIGNS

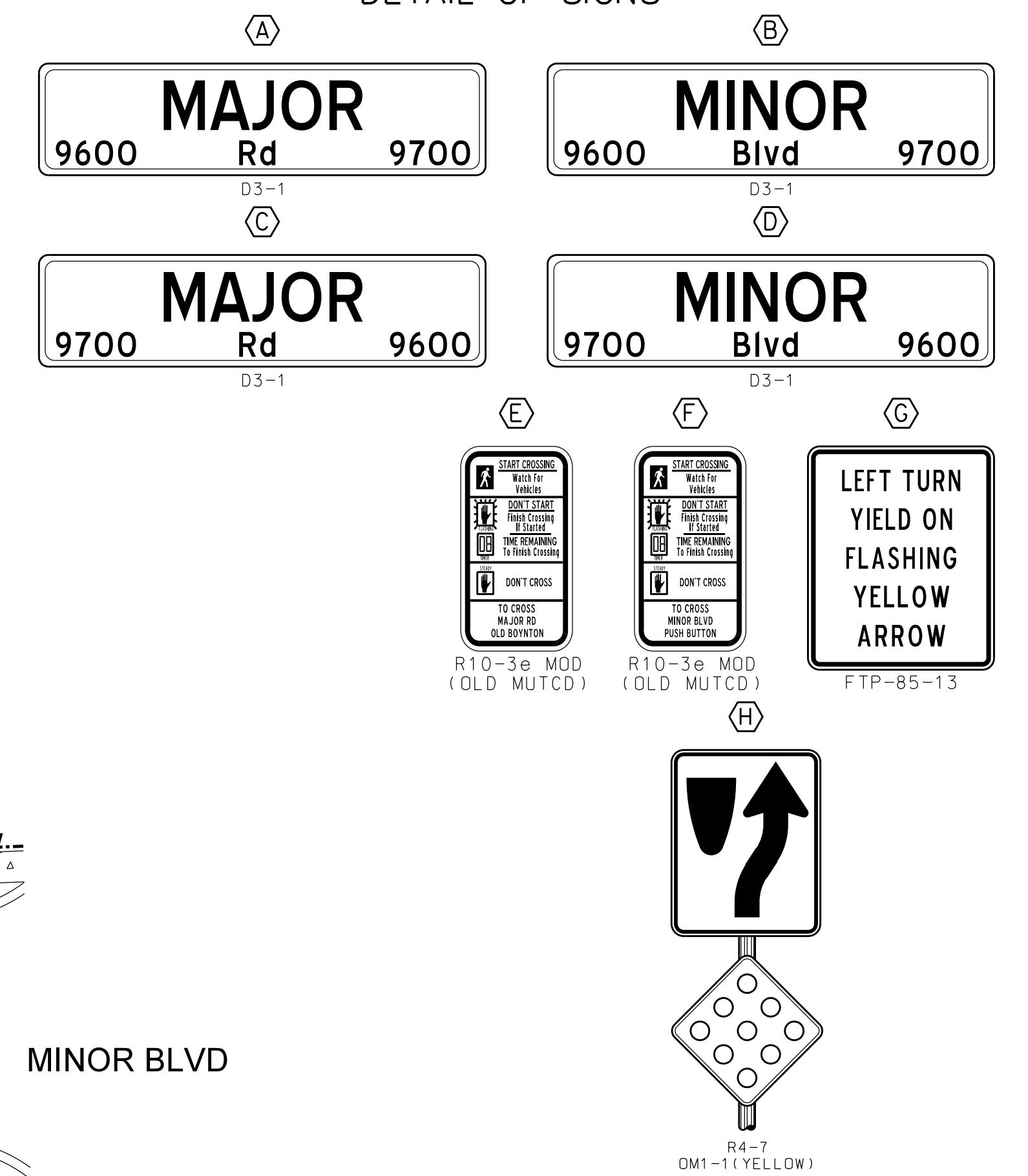

DESIGN NOTES:

- LUMINAIRE LOCATIONS:**
NE, NW, SE, SW (PBC) (LED)
- FLASHING OPERATION:**
YELLOW --- 2 AND 6
RED ----- 1F, 4, 4F, 5F, 8 AND 8F
- SPEED LIMITS:**
MINOR BLVD - 30 MPH
MAJOR RD - 45 MPH

NOTES:

- FLASHING YELLOW ARROW SIGNAL HEADS AND SIGNING TO BE USED ON BOTH SPAN WIRE AND MAST ARM SIGNALS.

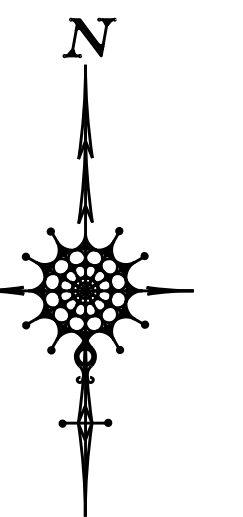
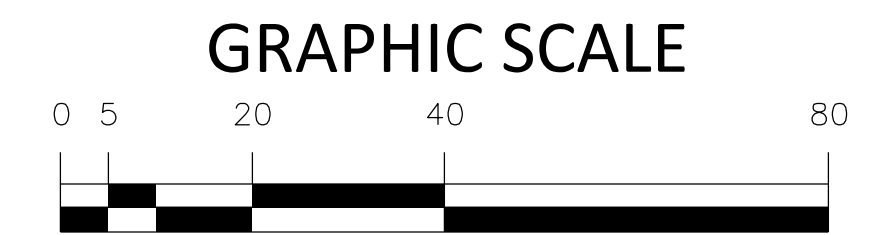
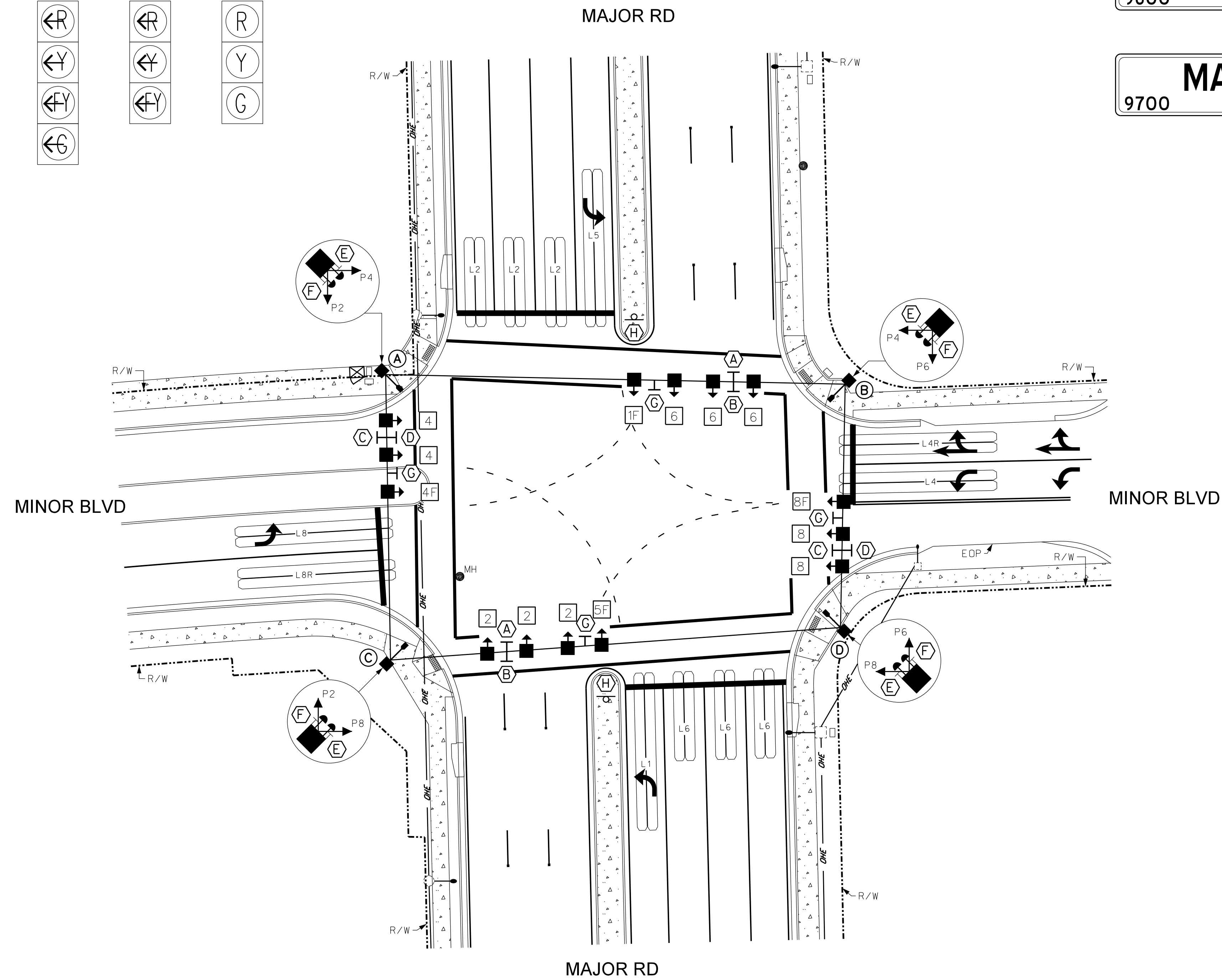

* SCALE AND ROW NOT SURVEY ACCURATE. ATTENTION IS DIRECTED TO THE FACT THAT THESE PLANS MAY HAVE BEEN ALTERED IN SIZE BY REPRODUCTION. THIS MUST BE CONSIDERED WHEN OBTAINING SCALED DATA.

- GENERAL NOTES:**
- THIS DRAWING IS NOT TO SCALE.
 - DESIGN, LAYOUT & DATA ON THIS SHEET ARE FOR ILLUSTRATION PURPOSE ONLY.

PALM BEACH COUNTY, FLORIDA
TRAFFIC DIVISION

SIGNAL TYPICAL

TYPICAL FYA
OPERATION AND
INSTALLATION

| | | | | | |
|------------------------|------|------|------------|--------------------|--|
| SIGNATURE | | DATE | | ENGINEER OF RECORD | |
| <i>Fatmeh N. Jafar</i> | | | | FATMEH N. JAFAR | |
| DRAWN BY | NAME | DATE | SCALE | CONTRACT NO. | |
| CHECKED BY | | | * N. T. S. | | |

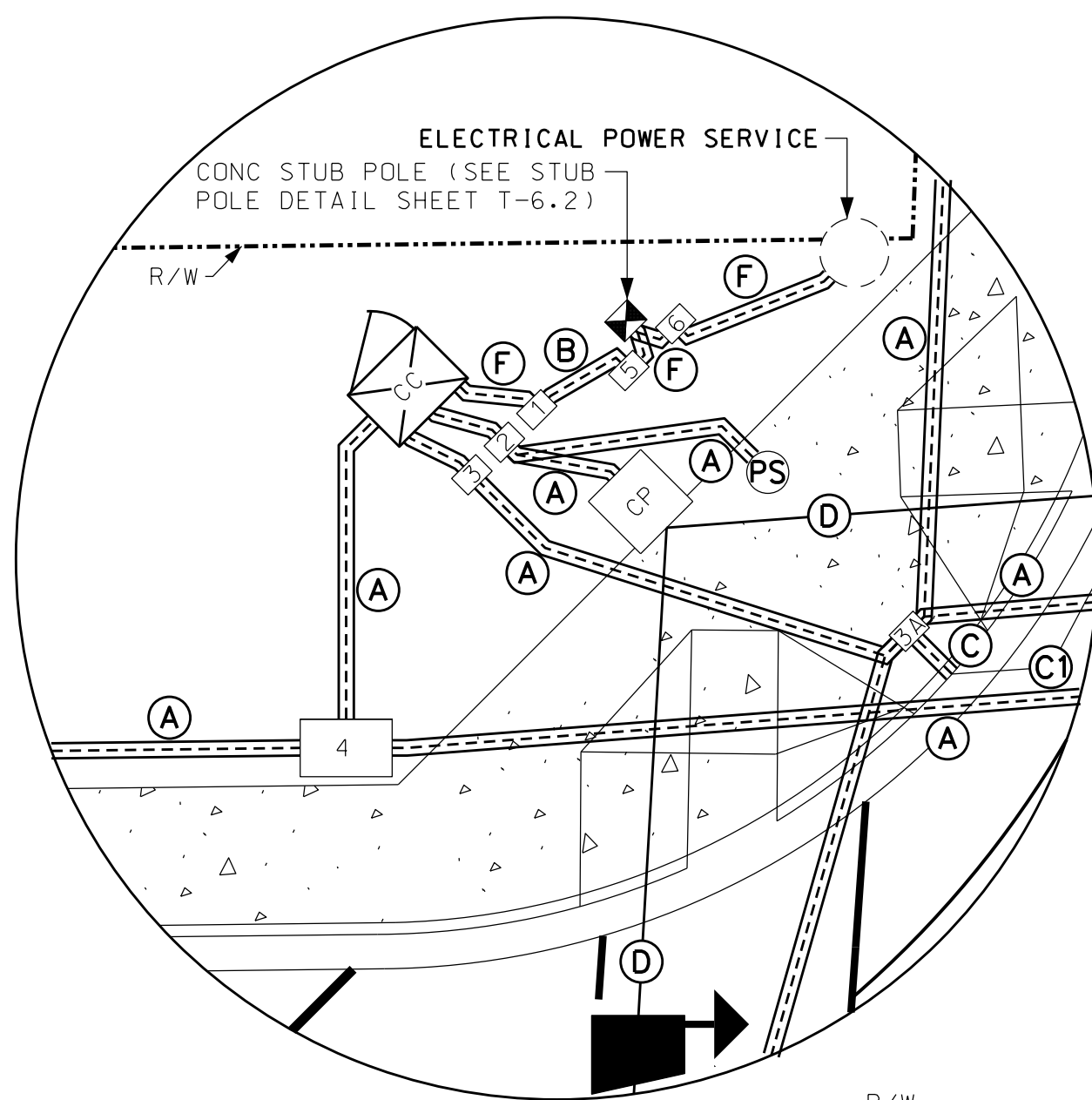

DETAIL "A"

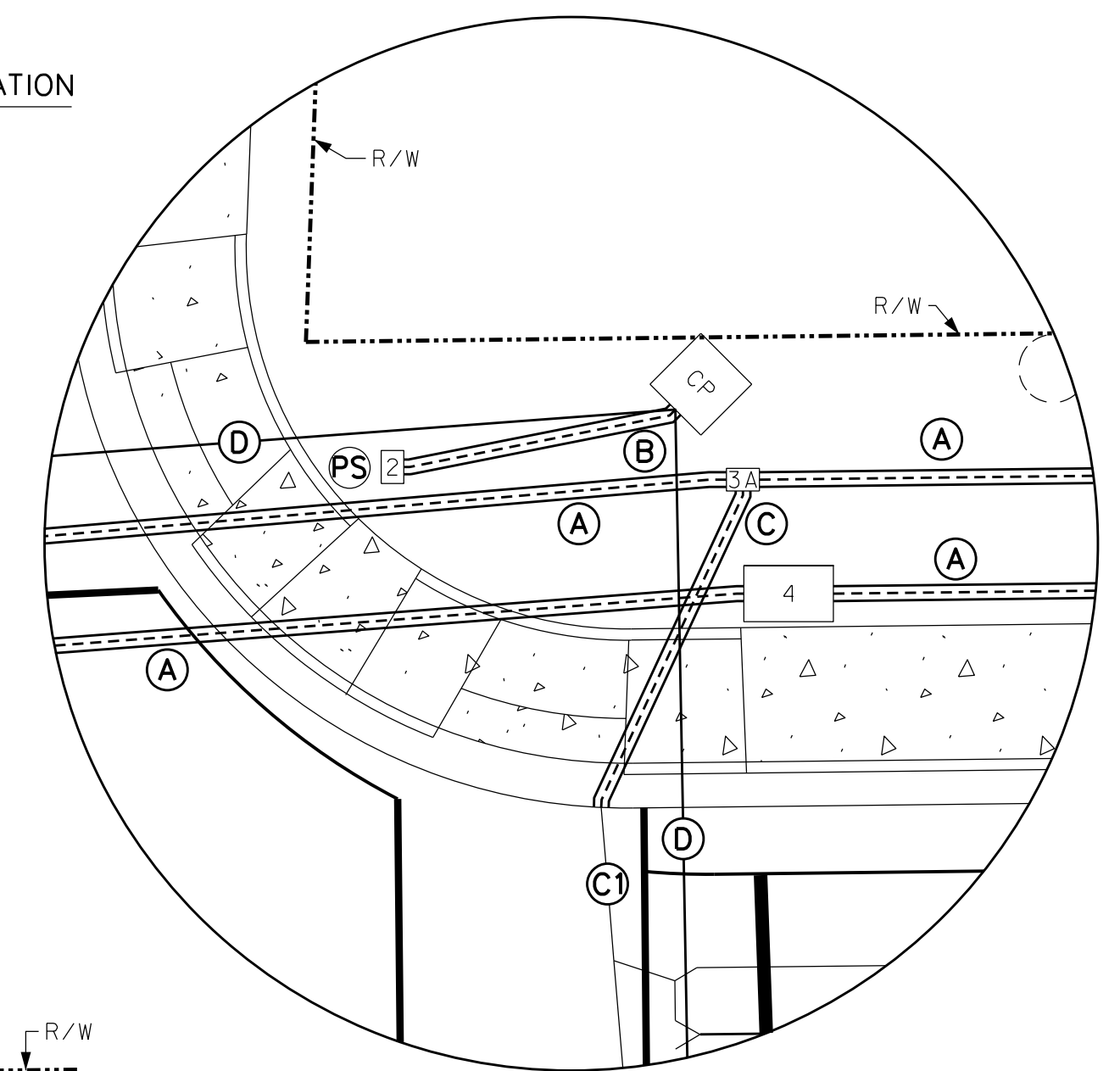

DETAIL "B"

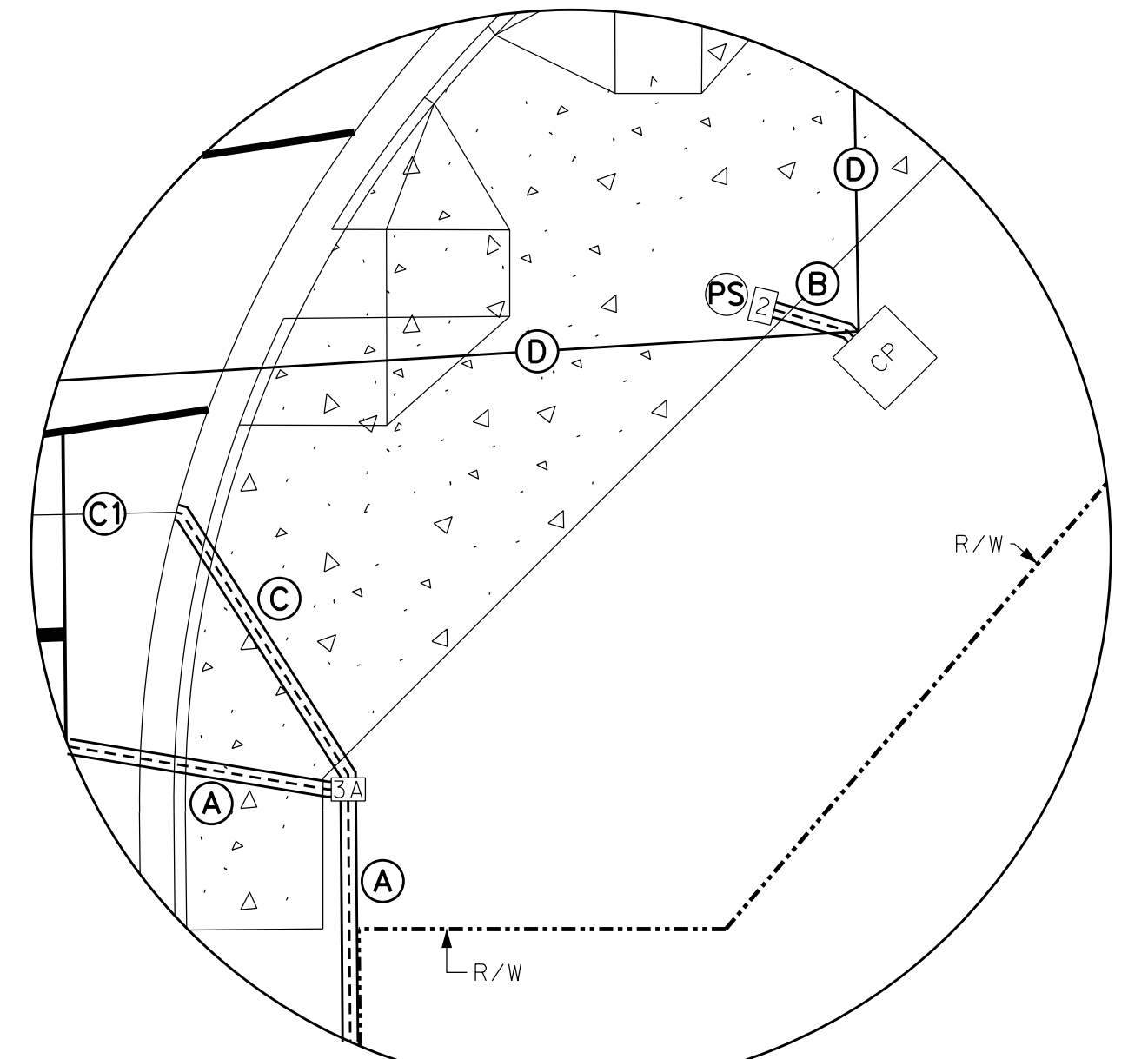

DETAIL "D"

LEGEND

- CC = CONTROLLER CABINET
- CP = CONCRETE POLE
- PS = PEDESTRIAN SIGNAL
- 1 = PULL BOX FOR POWER SERVICE (13X24X12)
- 2 = PULL BOX FOR SIGNAL & PEDESTRIAN CABLE (17X30X12)
- 3 = PULL BOX FOR ALL LOOPS (17X30X12)
- 3A = PULL BOX FOR CONNECTING STOP BAR LOOPS & FOR OPTIONAL ADVANCE LOOPS (17X30X12)
- 4 = PULL BOX FOR ITS (30X48X24), OPTIONAL SIZE (17X30X24) OR AS DETERMINED BY ENGINEER.
- 5 = PULL BOX FOR POWER SERVICE (17X30X12) OPTIONAL AS DETERMINED BY ENGINEER.
- 6 = PULL BOX FOR FPL POWER CONNECTION (17X30X12)
- A = 2-2" UNDERGROUND/UNDER PAVEMENT CONDUIT
- B = 1-2" UNDERGROUND/UNDER PAVEMENT CONDUIT (PVC)
- C = 2-2" UNDERGROUND CONDUIT FOR LOOP LEAD-IN (PIPE 1' (FT) UNDER CURB)
- C1 = LOOP LEAD-IN
- D = SPAN WIRE WHEN SPECIFIED WIRING (VIDEO OR MICROWAVE WITH SIGNAL CABLE)

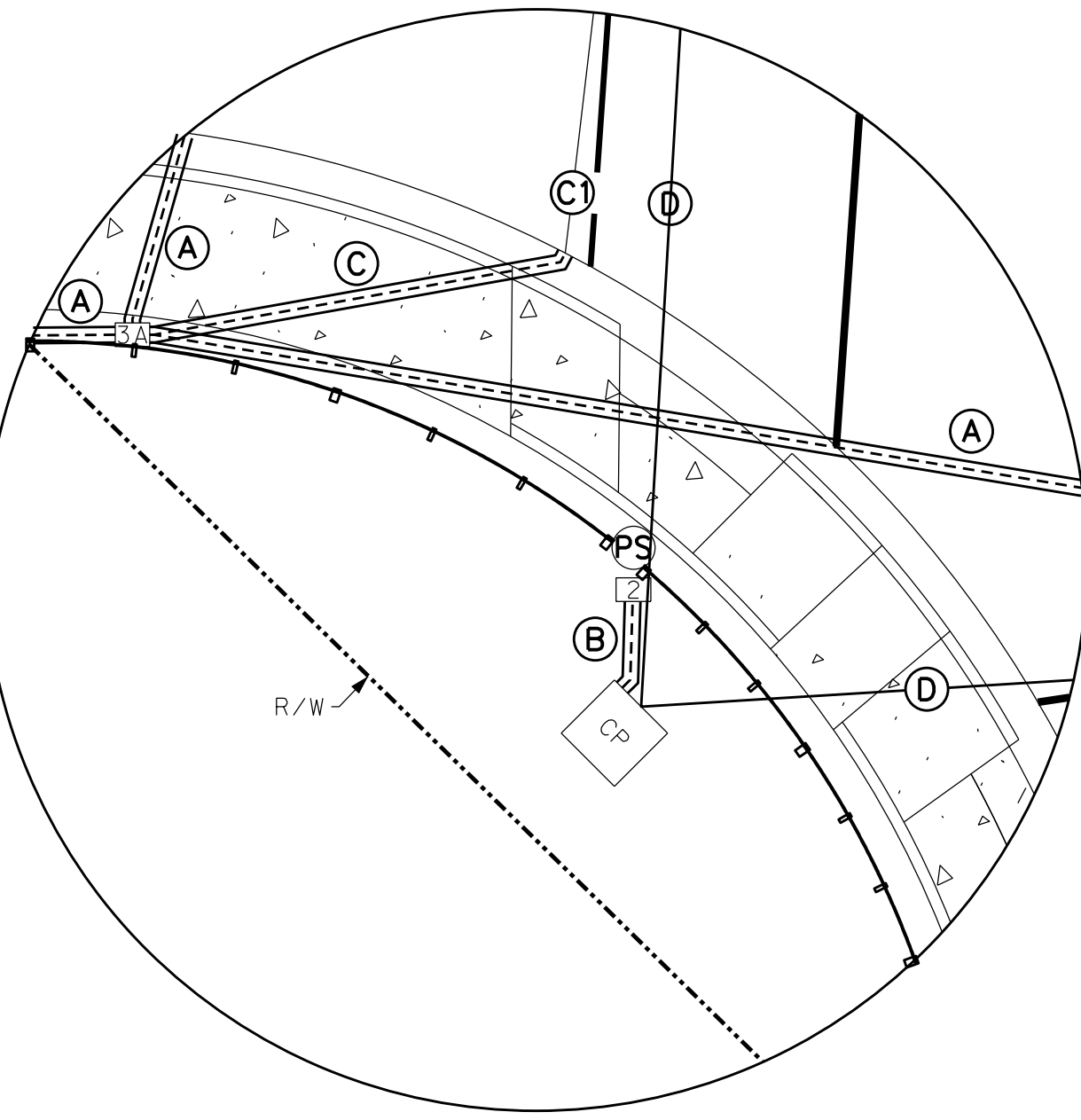

DETAIL "C"

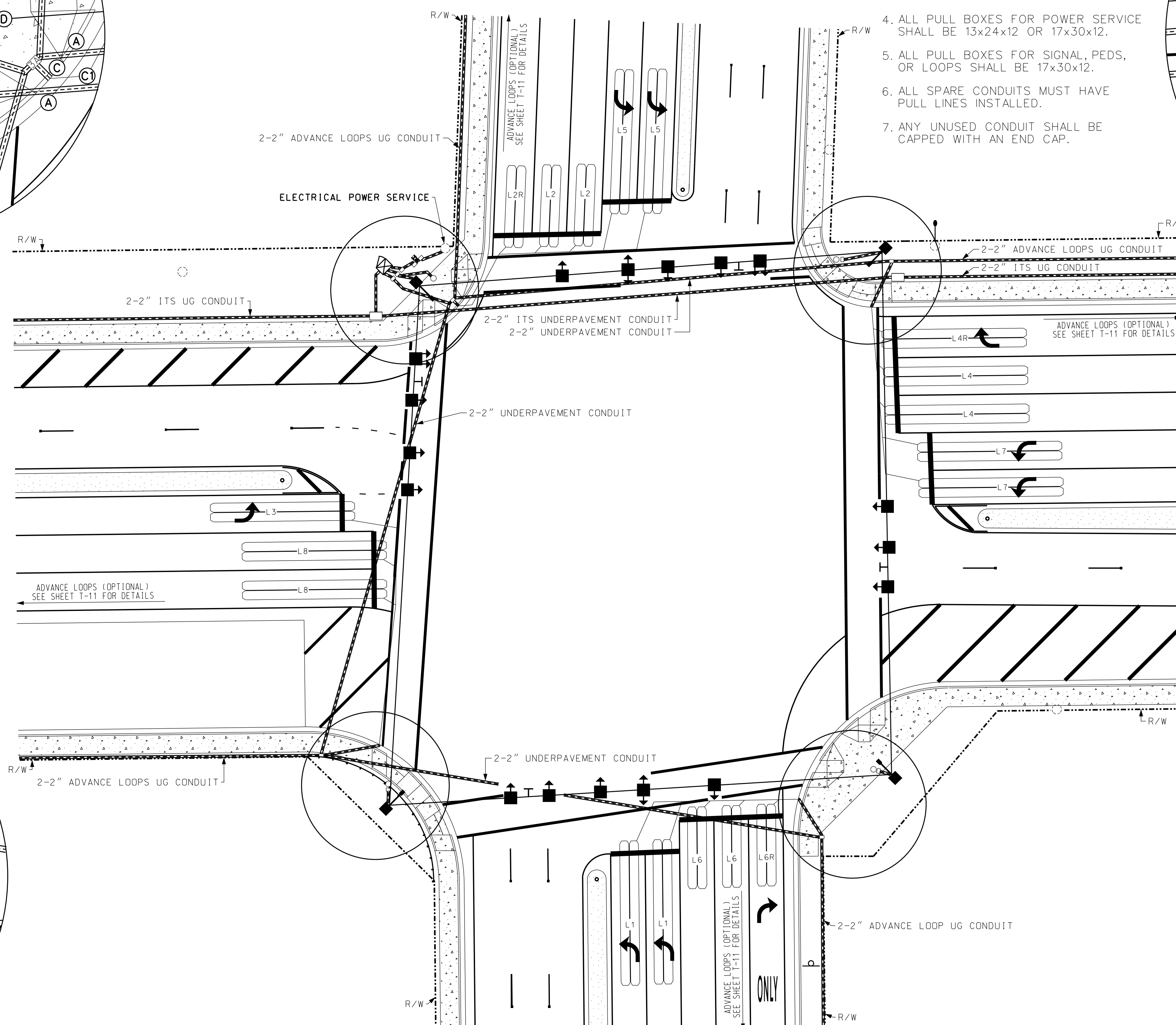

NOTES FOR MAST ARM & SPAN WIRE INSTALLATION

1. ANY CONDUIT ABOVE GROUND SHALL BE ALUMINUM OR HD GALVANIZED.
2. ANY CONDUIT BELOW GROUND SHALL BE SCHEDULE 40 ELECTRICAL PVC.
3. ANY VIDEO AND LOOPS USED AT AN INTERSECTION SHALL BE INSTALLED IN ITS OWN SEPERATE CONDUIT AND PULL BOX.
4. ALL PULL BOXES FOR POWER SERVICE SHALL BE 13x24x12 OR 17x30x12.
5. ALL PULL BOXES FOR SIGNAL, PEDS, OR LOOPS SHALL BE 17x30x12.
6. ALL SPARE CONDUITS MUST HAVE PULL LINES INSTALLED.
7. ANY UNUSED CONDUIT SHALL BE CAPPED WITH AN END CAP.

GENERAL NOTES:
 1. THIS DRAWING IS NOT TO SCALE.
 2. DESIGN, LAYOUT & DATA ON THIS SHEET ARE FOR ILLUSTRATION PURPOSE ONLY.

**PALM BEACH COUNTY, FLORIDA
 TRAFFIC DIVISION
 SIGNAL TYPICAL**

**CABLES DISTRIBUTION SYSTEM
 FOR SPAN WIRE INSTALLATION**

SIGNATURE: *Fatme N. Jafar* DATE: _____ FATMEH N. JAFAR
 ENGINEER OF RECORD
 DRAWN BY: _____ SCALE: _____ CONTRACT NO. _____
 CHECKED BY: _____ * N. T. S.

| NO. | DATE | REVISIONS | BY | APP. |
|-----|------|-----------|----|------|
| | | | | |

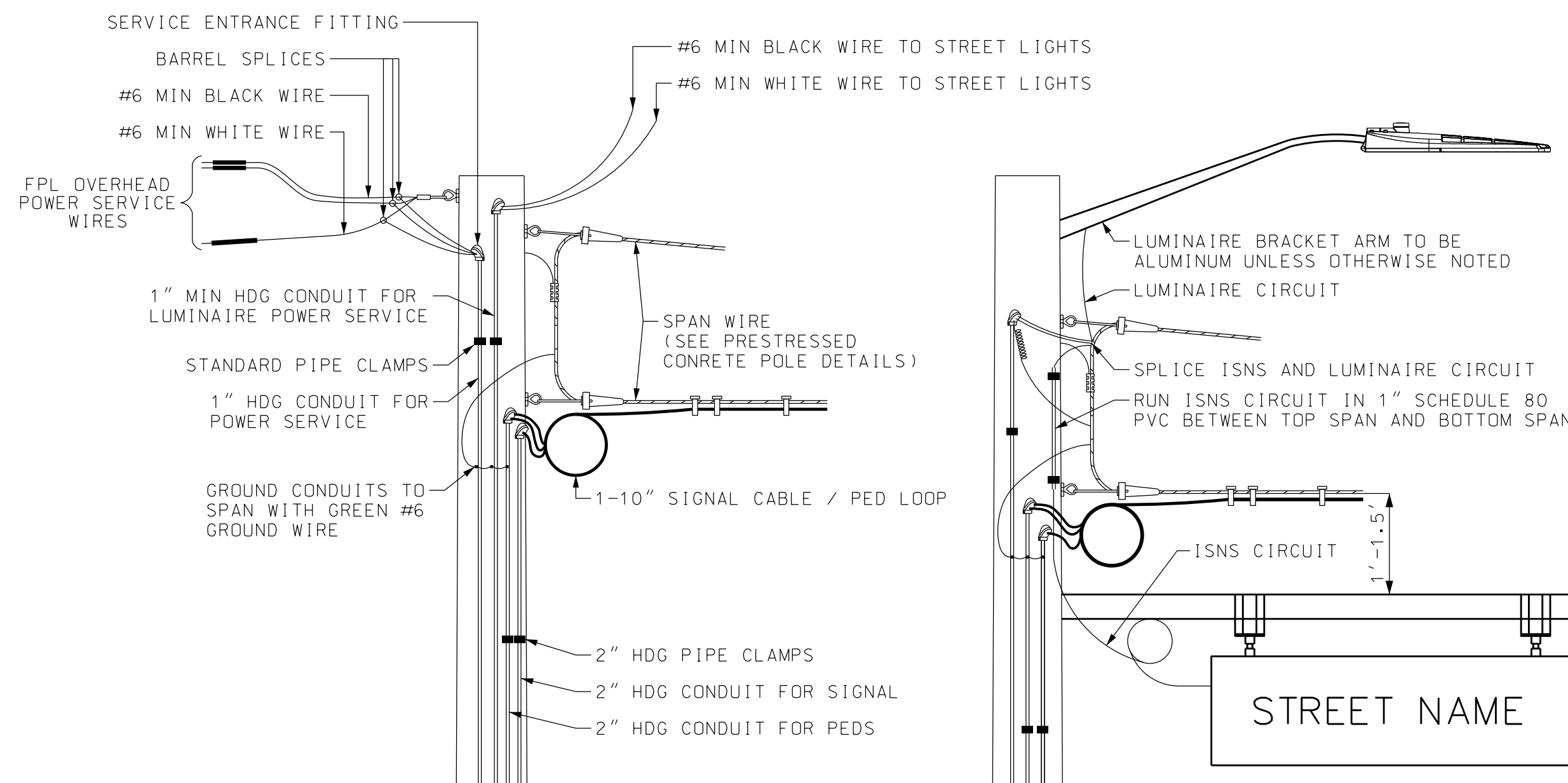

LUMINAIRE / ISNS WIRING DETAIL

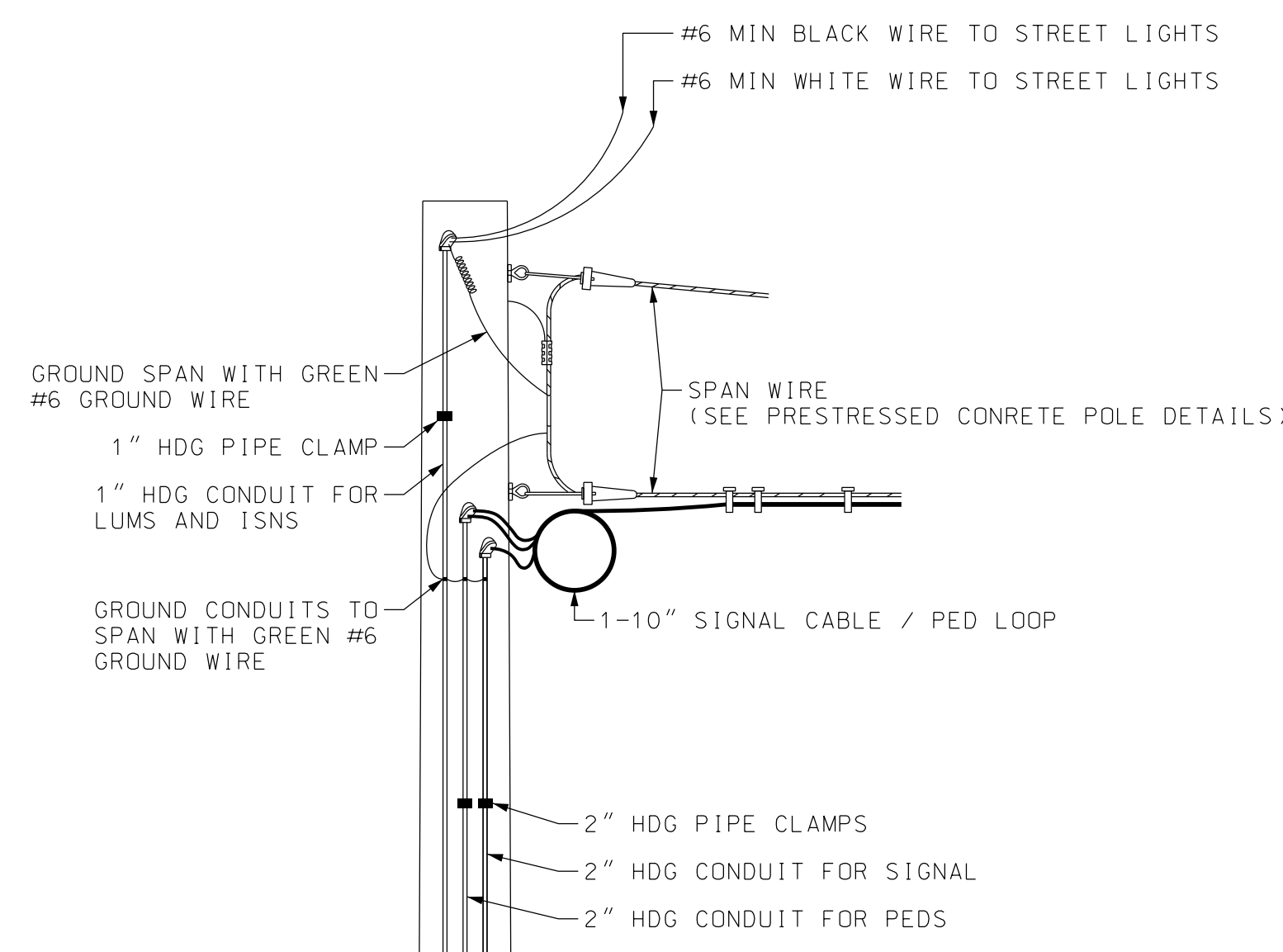

CONCRETE POLE DETAIL (UNDERGROUND SERVICE)

NOTES:

1. BREAKER BOX SQUARE D MODEL #0024L70RB, OR APPROVED EQUIVALENT.
2. THE LIGHTING ARRESTOR TO BE LOCATED ON THE SIDE OF THE MAIN DISCONNECT ENCLOSURE.
3. THE MAIN DISCONNECT SHALL BE LOCKABLE.
4. THE MAIN DISCONNECT ENCLOSURE SHALL BE NEMA 4X OR BETTER.
5. FOR GROUNDING ROD INFORMATION SEE NOTES ON T-6.3.
6. BOND ALL ELEMENTS TOGETHER TO FORM AN INTERSECTION GROUNDING NETWORK IN ACCORDANCE WITH SECTION 620 OF THE FDOT CURRENT STANDARD SPECIFICATIONS FOR ROAD AND BRIDGE CONSTRUCTION. THE BOND WIRE SHALL BE RUN IN CONDUIT WITH THE ELECTRICAL SERVICE WIRE OR SIGNAL CABLE.
7. STAINLESS STEEL FLEXIBLE CONDUITS ARE APPROVED FOR USE FROM THE ELECTRICAL DISCONNECT TO THE CABINET THEN BOTH ARE ON THE SAME POLE AND INSULATED.
8. NEW INSTALLATIONS REQUIRE COMPLETE HARDWARE AS SHOWN FOR THE OPTION: INSTALLATION AT EXISTING SIGNALS REQUIRE NEW DEVICE WIRE, SECOND BREAKER, CONDUIT RISER, AND OTHER ASSOCIATED HARDWARE FOR COMPLETE AND OPERATIONAL PRODUCT. GROUNDING IS REQUIRED FOR ALL PROJECTS.
9. LUMINAIRE SERVICE TO BE TIE-WRAPPED TO CATENARY (UPPER) CABLE, SPACED MAXIMUM OF 1 FOOT APART.
10. THE LUMINAIRE SERVICE SHALL HAVE A SEPARATE BREAKER INSIDE THE MAIN DISCONNECT.
11. MINIMUM CLEARANCE FROM BOTTOM OF NIPPLE TO GROUND LEVEL IS TO BE 8 FEET.
12. ALL ABOVE GROUND METAL CONDUITS TO BE BONDED WITH BONDING CLAMPS WHEN TRANSITIONED FROM PVC. IF ENTIRE RUN IS METAL BONDING SHALL BE DONE IN PULL BOX WITH GROUNDING BUSHING.

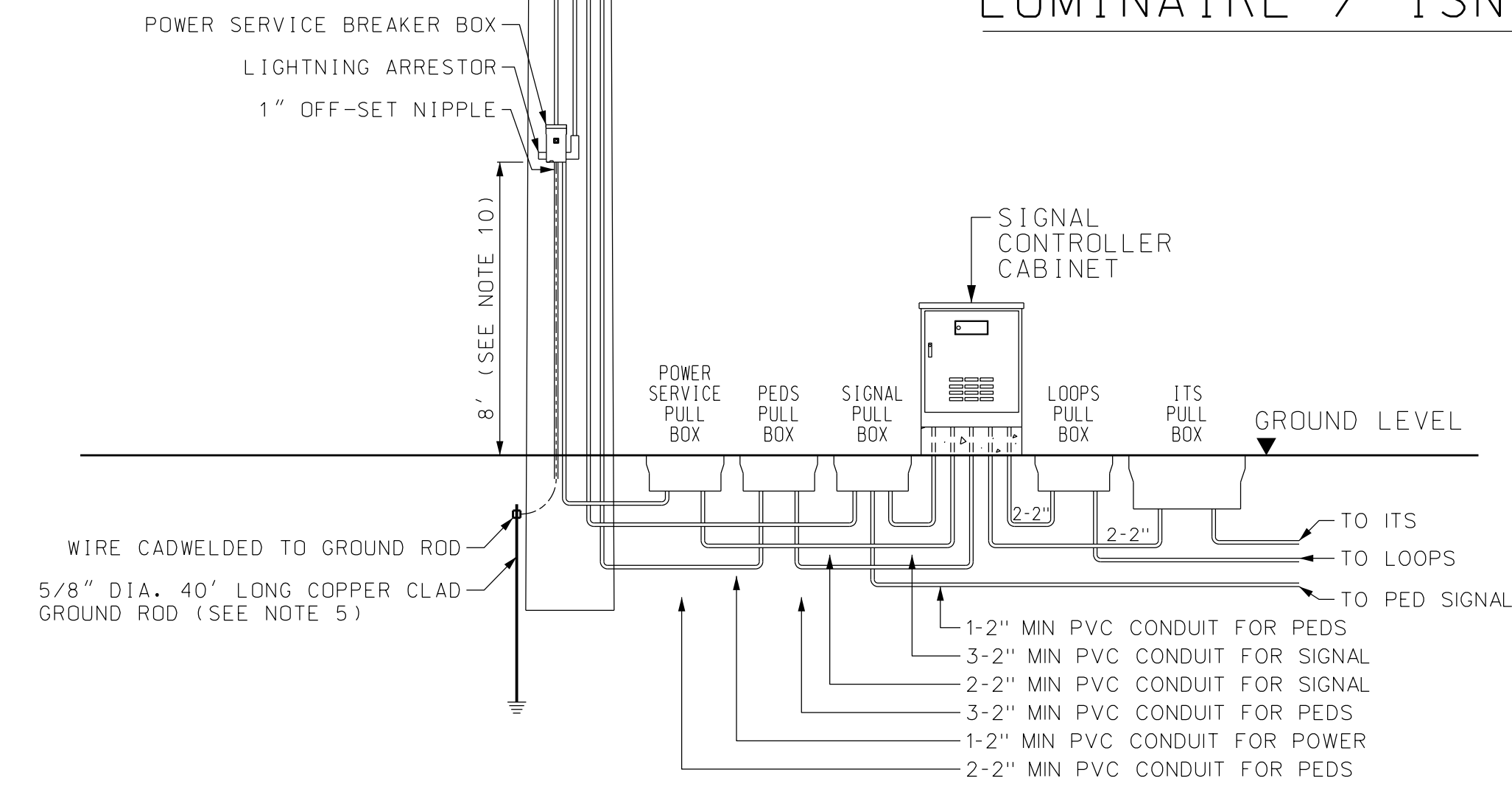

CONCRETE POLE DETAIL (OVERHEAD SERVICE)

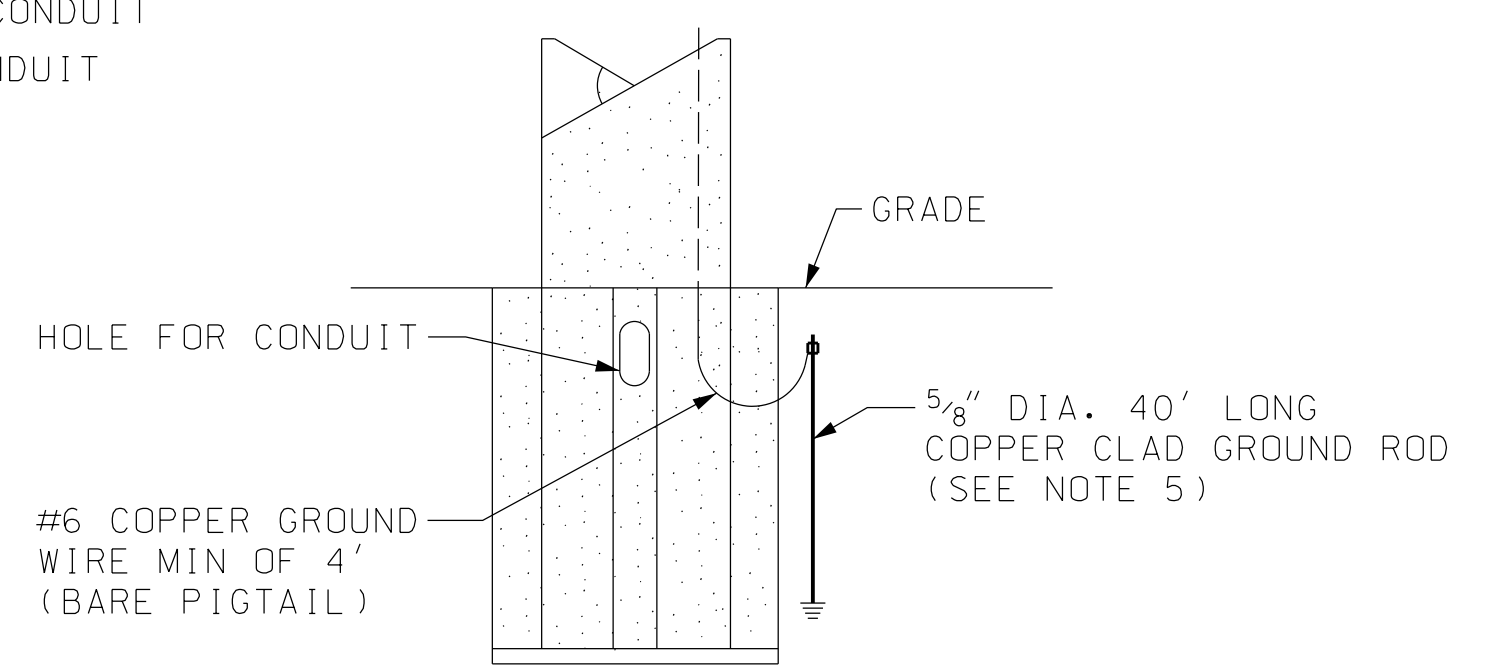
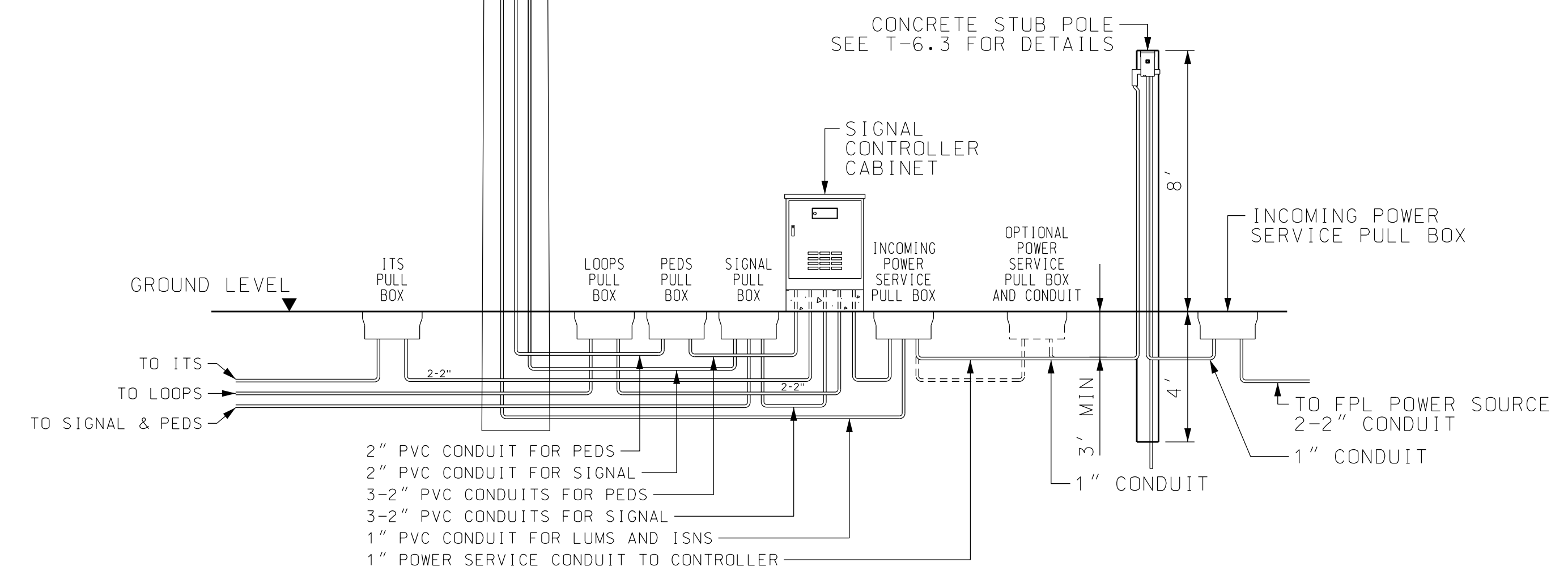

PRESTRESSED CONCRETE POLE DETAIL

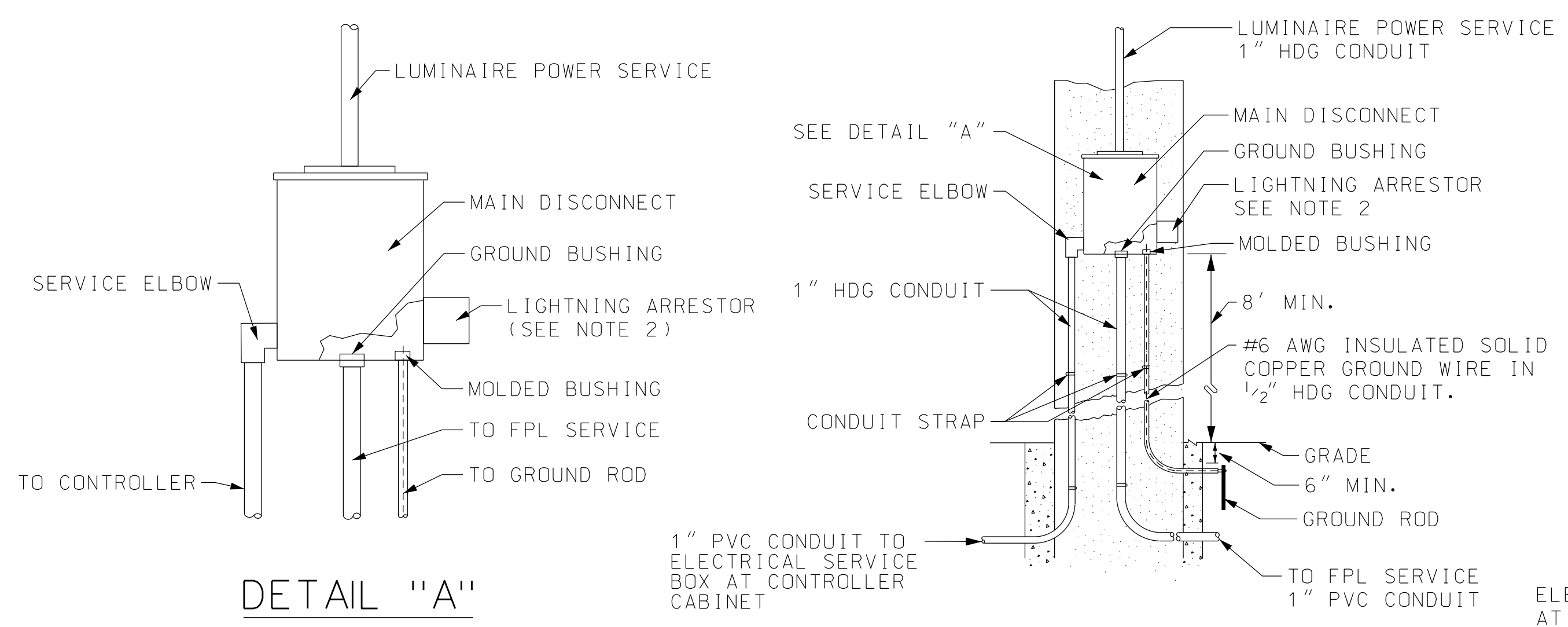

MAIN DISCONNECT / UNDERGROUND FEED DETAIL

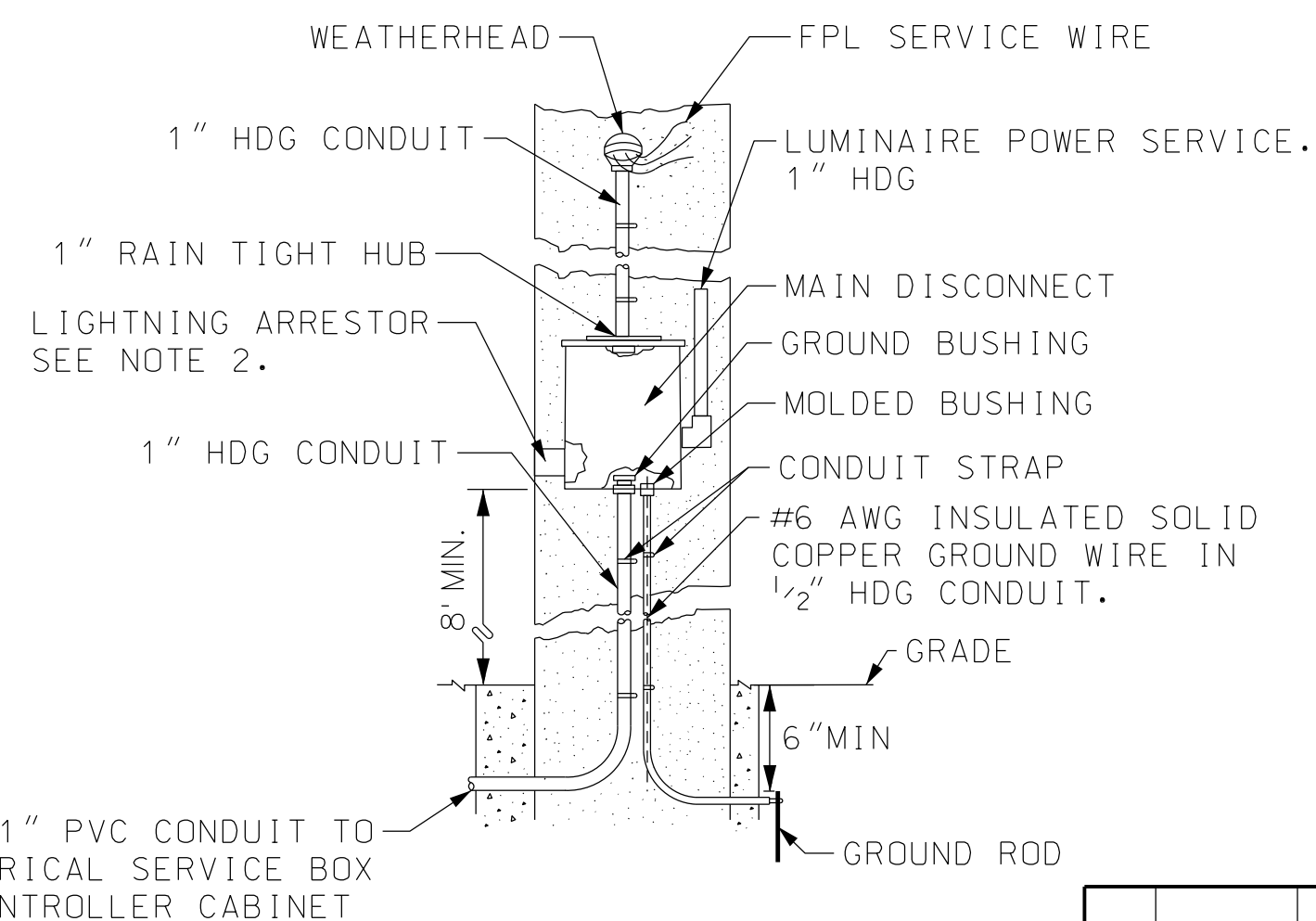

AERIAL FEED DETAIL

GENERAL NOTES:
 1. THIS DRAWING IS NOT TO SCALE.
 2. DESIGN, LAYOUT & DATA ON THIS SHEET ARE FOR ILLUSTRATION PURPOSE ONLY.

PALM BEACH COUNTY, FLORIDA
 TRAFFIC DIVISION
 SIGNAL TYPICAL
 CONCRETE SERVICE POLE
 DETAIL FOR SPAN WIRE
 LUMINAIRE WIRING DETAIL

SIGNATURE: *Fatme N. Jafar* DATE: _____ FATMEH N. JAFAR
 ENGINEER OF RECORD
 DRAWN BY: _____ SCALE: * N. T. S. CONTRACT NO.: _____
 CHECKED BY: _____

| NO. | DATE | REVISIONS | BY | APP. |
|-----|------|-----------|----|------|
| | | | | |

TYPICAL GUYING & CLEAR ZONE (NO EXCAVATION) DETAIL

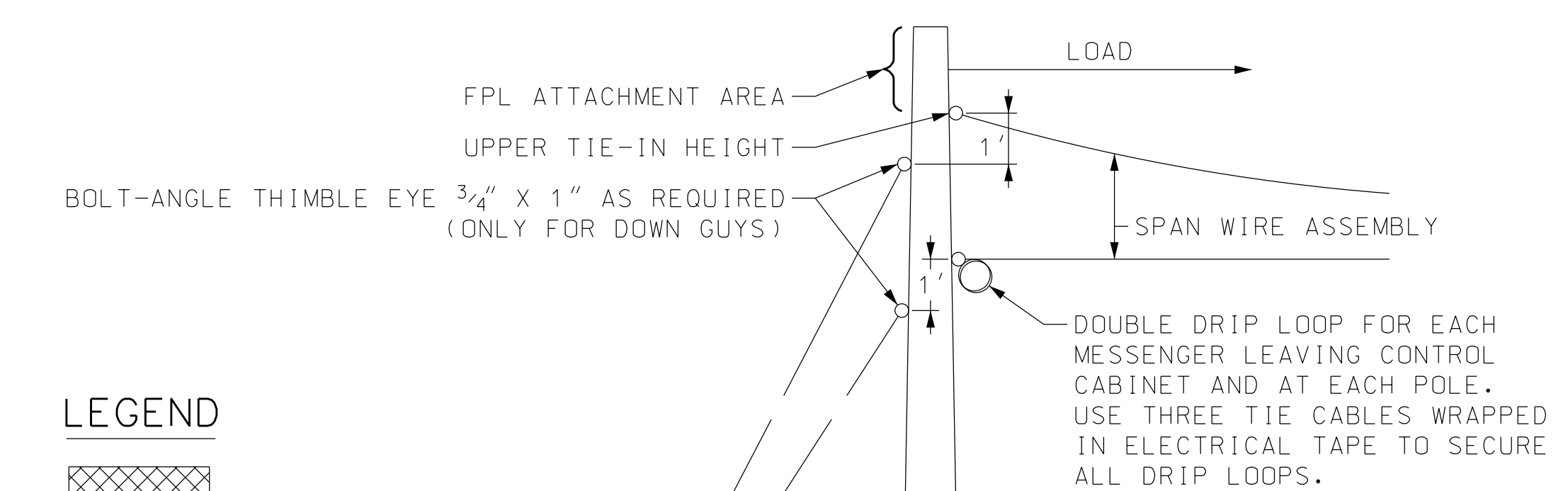

LEGEND

RESTRICTED EXCAVATION AREAS AROUND TRAFFIC SIGNAL POLES. MATERIAL NOT TO BE DISTURBED.

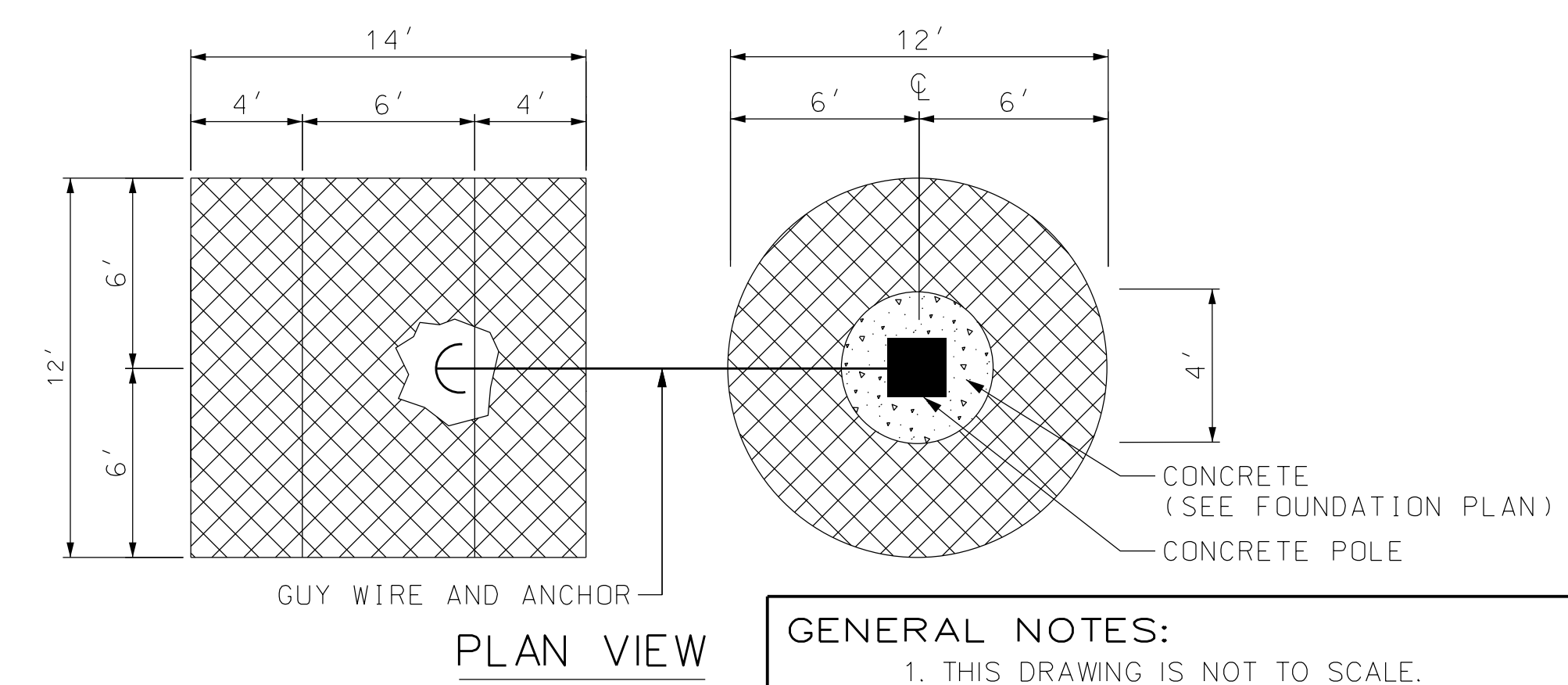
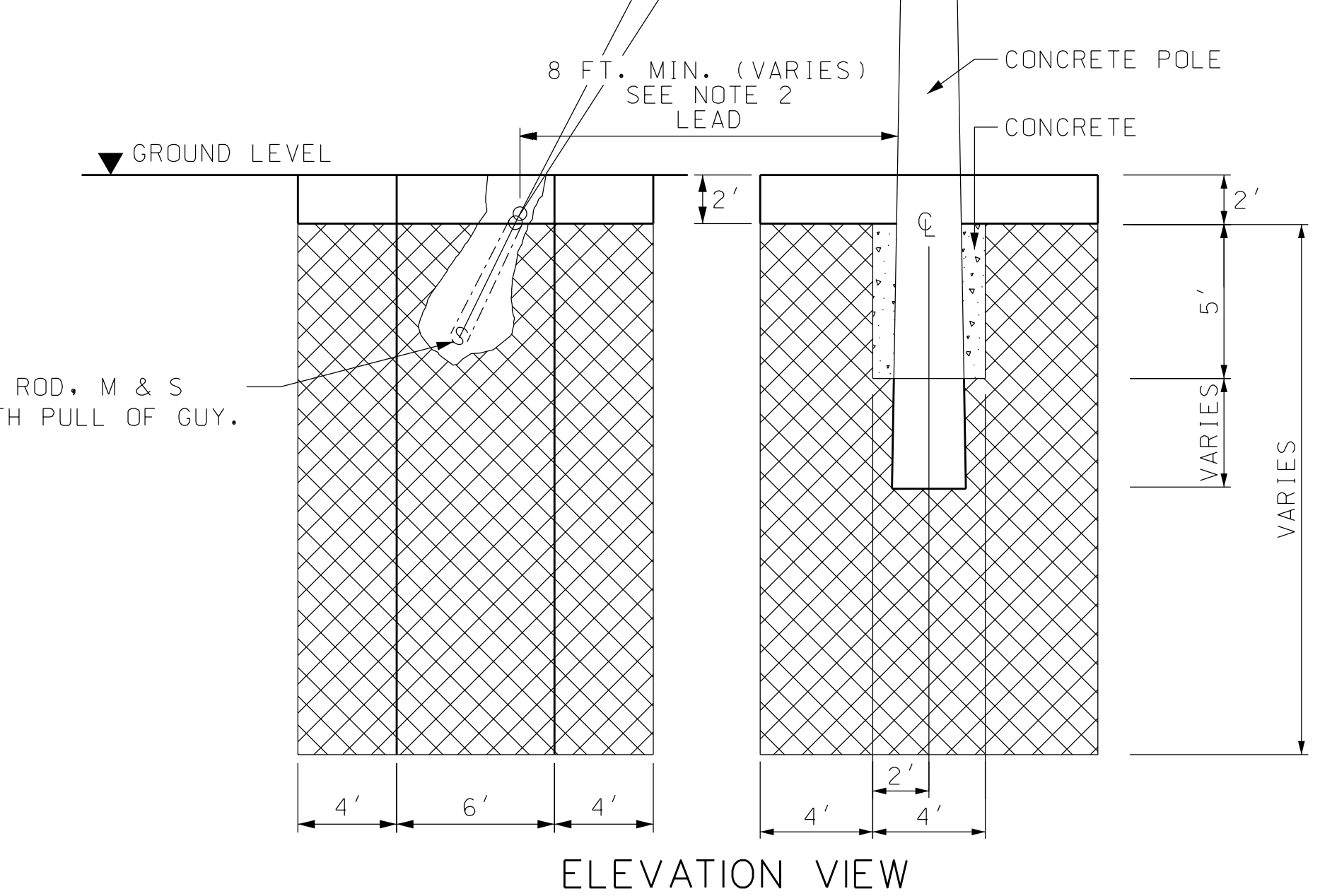

GENERAL NOTES:
 1. THIS DRAWING IS NOT TO SCALE.
 2. DESIGN, LAYOUT & DATA ON THIS SHEET ARE FOR ILLUSTRATION PURPOSE ONLY.

**PALM BEACH COUNTY, FLORIDA
 TRAFFIC DIVISION
 SIGNAL TYPICAL**

**CONCRETE POLE,
 TYPICAL GUYING CLEAR ZONE,
 STANDARD LUMINAIRE DETAIL**

SIGNATURE: *Fatme N. Jafar* DATE: _____ FATMEH N. JAFAR
 ENGINEER OF RECORD
 DRAWN BY: _____ DATE: _____ SCALE: _____ CONTRACT NO. _____
 CHECKED BY: _____ * N. T. S.

| NO. | DATE | REVISIONS | BY | APP. | SCALE | CONTRACT NO. |
|-----|------|-----------|----|------|-------|--------------|
| | | | | | | |

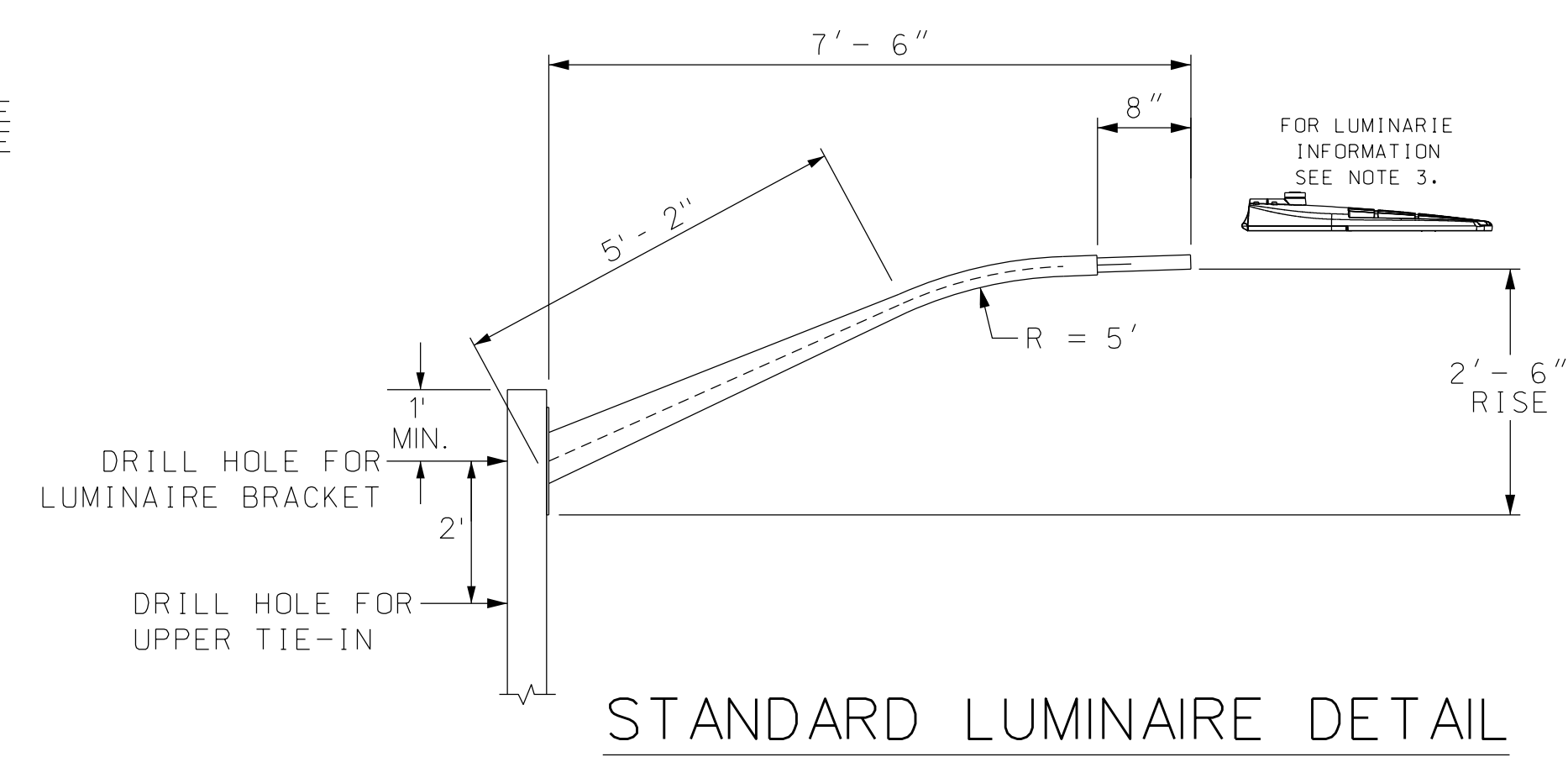

STANDARD LUMINAIRE DETAIL

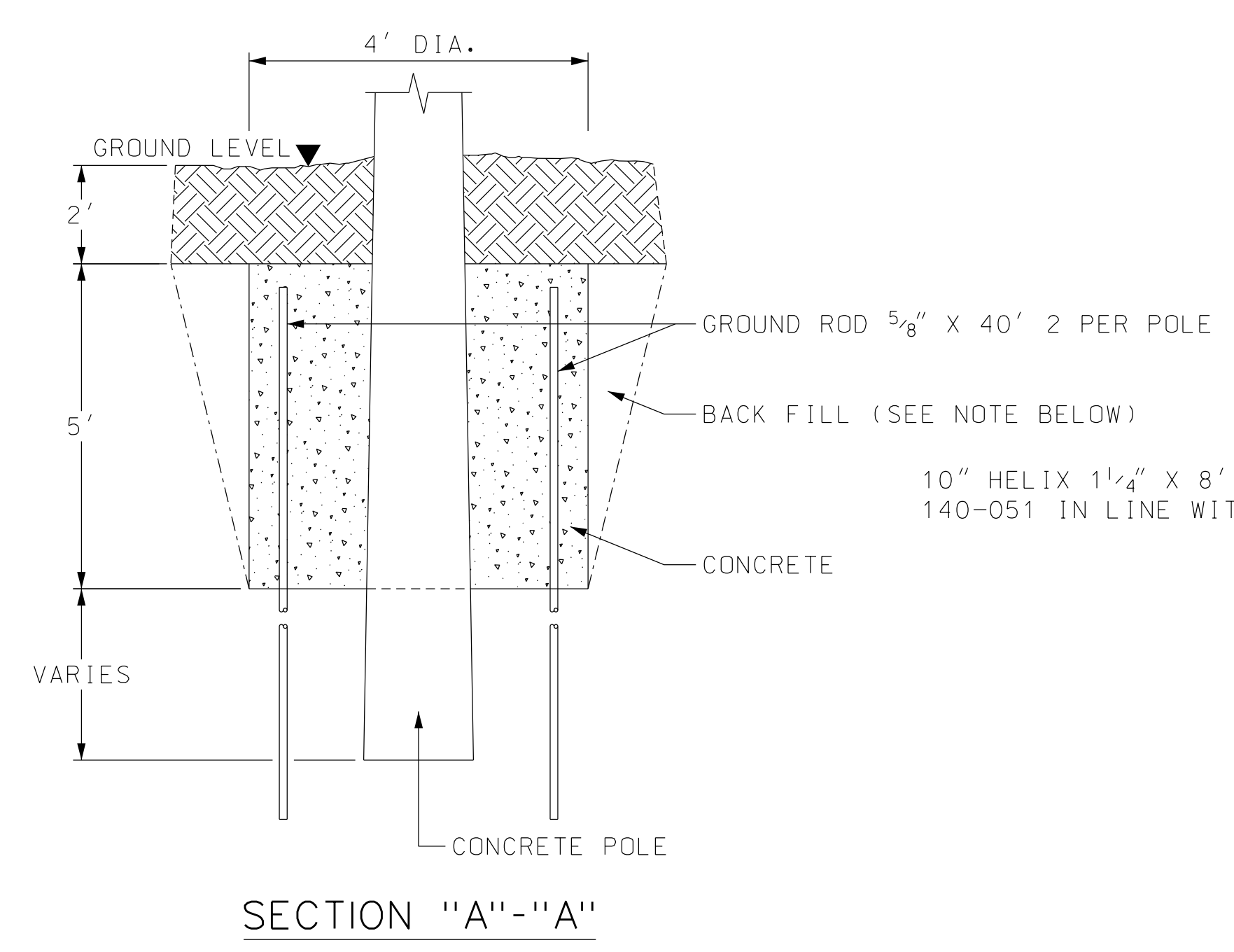

SECTION "A"- "A"

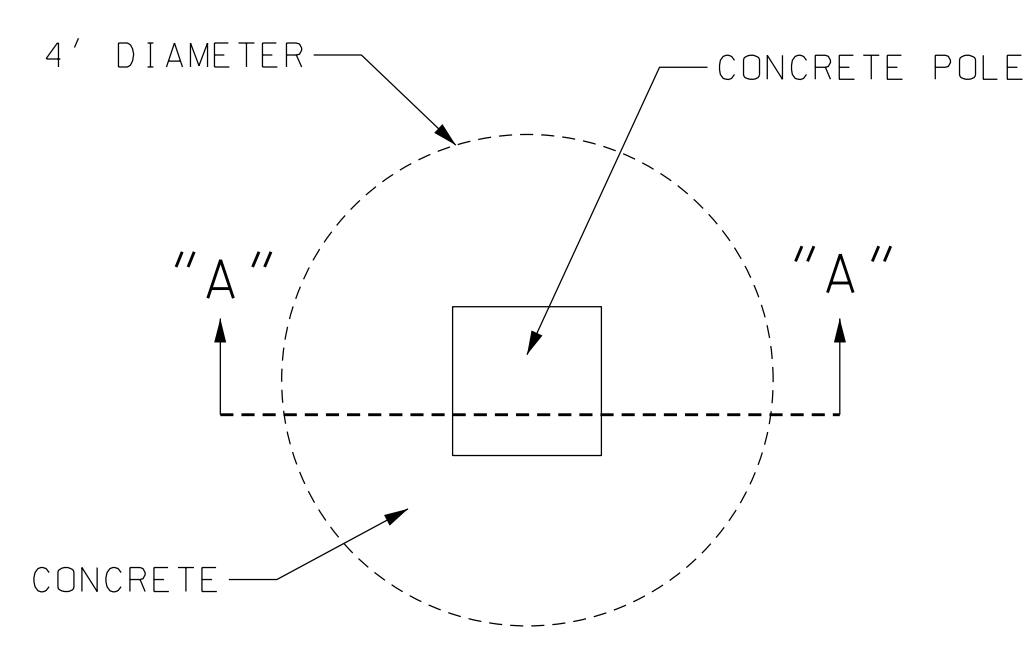

FOUNDATION PLAN

A = UPPER TIE IN FROM TOP OF POLE
 B = LOWER TIE IN FROM TOP OF POLE
 C = SERVICE POINT
 D = POLE HEIGHT
 E = POLE DEPTH BELOW GROUND

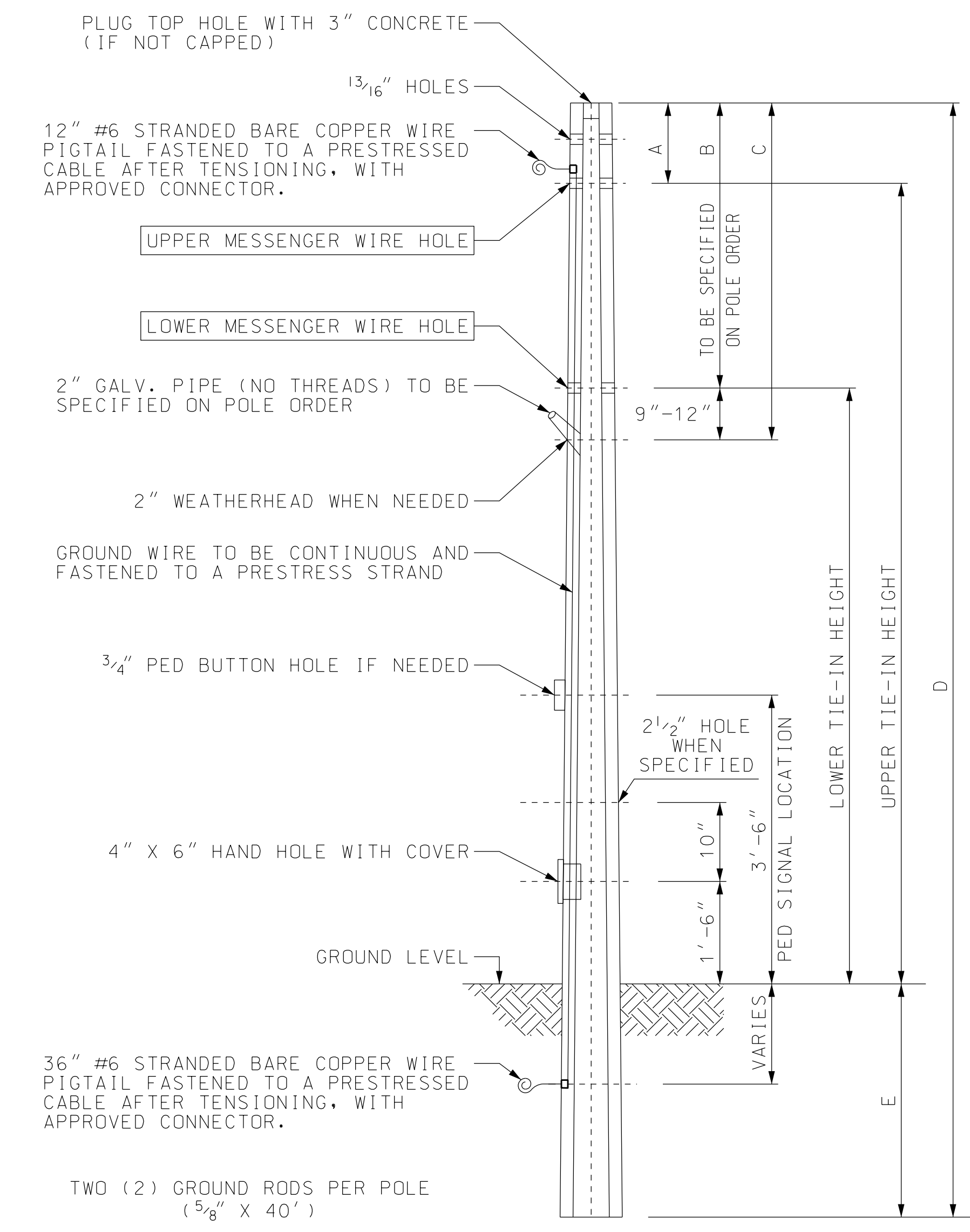

CONCRETE POLE DETAIL

AT THE OPTION OF THE CONTRACTOR, A PRECAST LEVELING PAD MAY BE USED AS SHOWN BELOW.

- * CLASS VI P POLE - 3.5 CU. YDS. MIN. CONCRETE PER POLE BASE
- * CLASS VII P POLE - 4 CU. YDS. MIN. CONCRETE PER POLE BASE
- * CLASS VIII P POLE - 5 CU. YDS. MIN. CONCRETE PER POLE BASE

FOUNDATION NOTES:

EXCAVATION & BACKFILL: EXCAVATION AND BACKFILL FOR THE FOOTINGS SHALL BE IN ACCORDANCE WITH ARTICLES 125-4 AND 125-8.2 WITH THE EXCEPTION OF THE BACKFILL IN LIEU OF THE REQUIREMENTS FOR OBTAINING THE SPECIFIED DENSITY, MAY BE HAND TAMPED IN FOUR INCH MAXIMUM LAYERS OR MACHINE TAMPED IN MAXIMUM SIX INCH LAYERS. THE MATERIAL SHOULD BE NEITHER DRY NOR SATURATED. BACKFILLING SHALL BE DONE WITH POURED CONCRETE SUFFICIENT TO FILL CAVITY.

CONCRETE: FOOTING & BACKFILL TO BE POURED WITH 2500 PSI CONCRETE (PER FDOT SSRBC SECTION 346 & 347).

FORMS: SHALL BE IN ACCORDANCE WITH ARTICLE 400-5 IF THE FOOTING IS POURED IN AN OVERSIZE HOLE, THE CONCRETE IN THE TOP SIX INCHES SHALL BE PLACED IN A FORM. ALL EXPOSED SURFACES SHALL BE TROWELLED TO A SMOOTH FINISH, AND 48" TUNNEL LINERS SHALL BE USED.

NOTES:

1. TRAFFIC SIGNAL POLES TO BE LOCATED WITHIN RIGHT OF WAY AND MAINTAIN CLEARANCES AS SPECIFIED BY FDOT LATEST DESIGN STANDARDS.
2. GUY WIRE LEAD DISTANCE TO BE 8 FT. MINIMUM OR AS SPECIFIED BY STRUCTURAL ANALYSIS.
3. LED LUMINAIRES ARE TO BE AUTOBAHN SERIES ATB2 OR EQUAL TO BE APPROVED BY PALM BEACH COUNTY ENGINEER.
4. EACH LUMINAIRE SHALL HAVE ITS OWN SEPERATE PHOTOCCELL.
5. FOR GROUNDING ROD INFORMATION SEE NOTES ON T-6.3.
6. FOR LUMINAIRE WIRING SPECS SEE NOTES ON T-5.3.

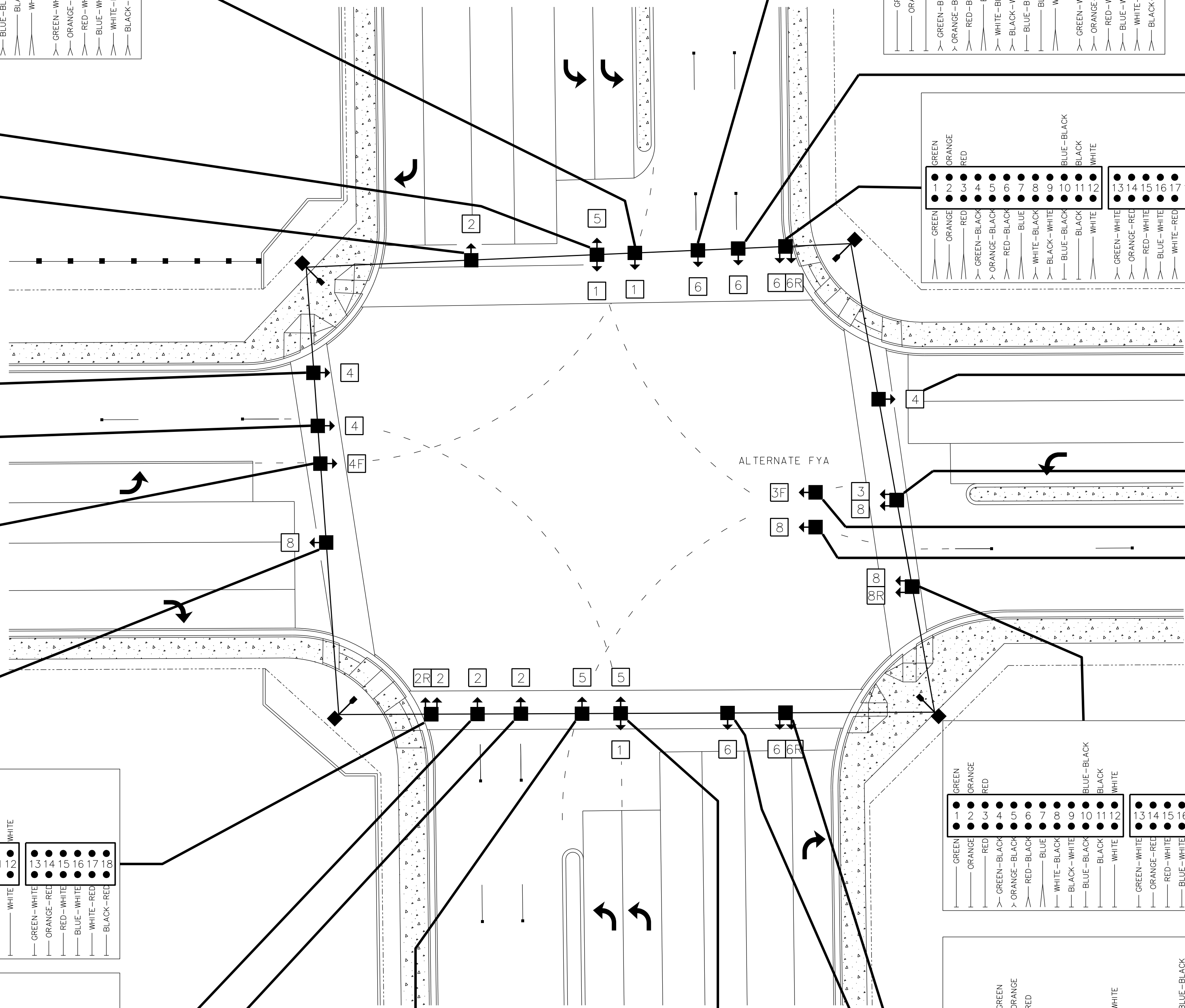
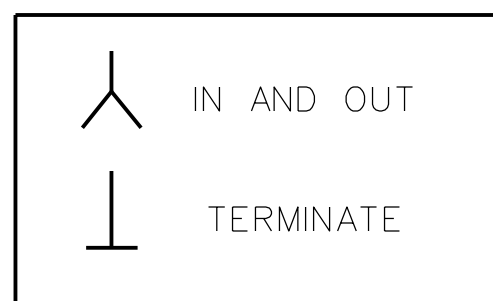
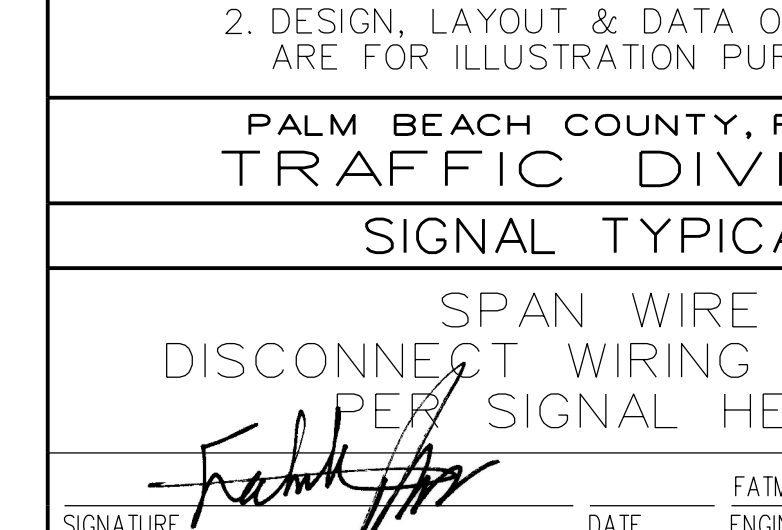
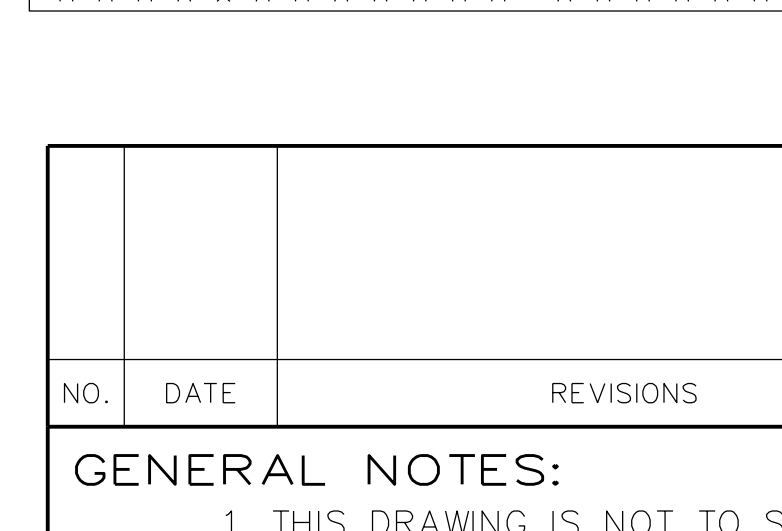
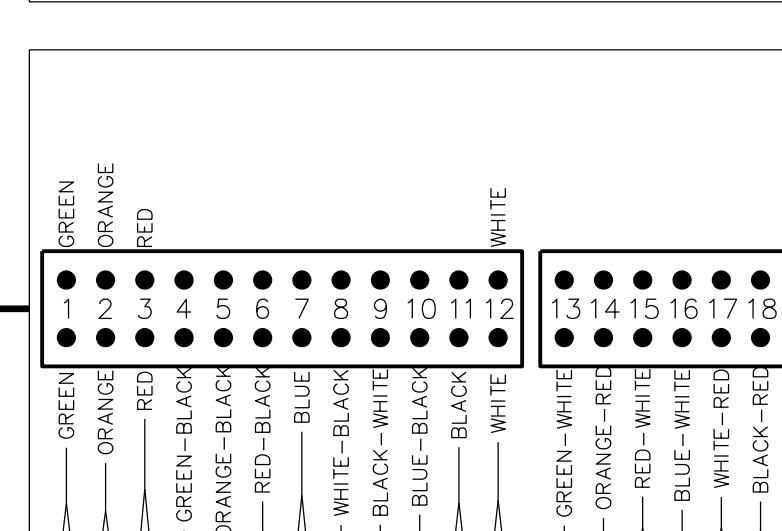
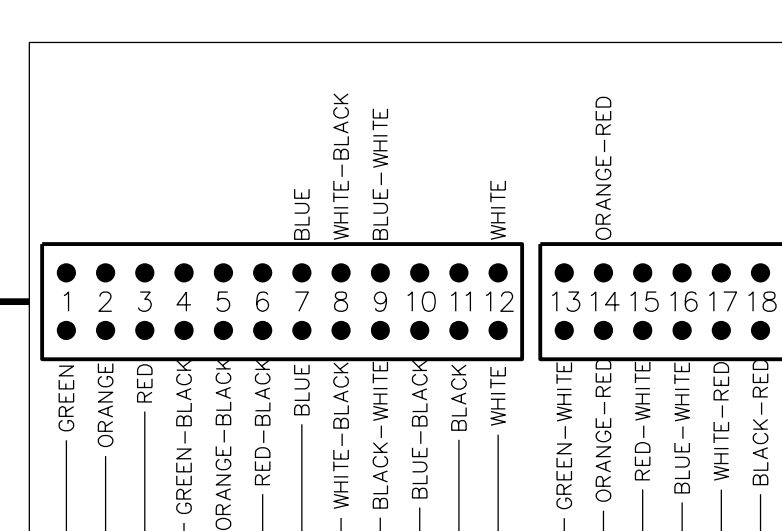
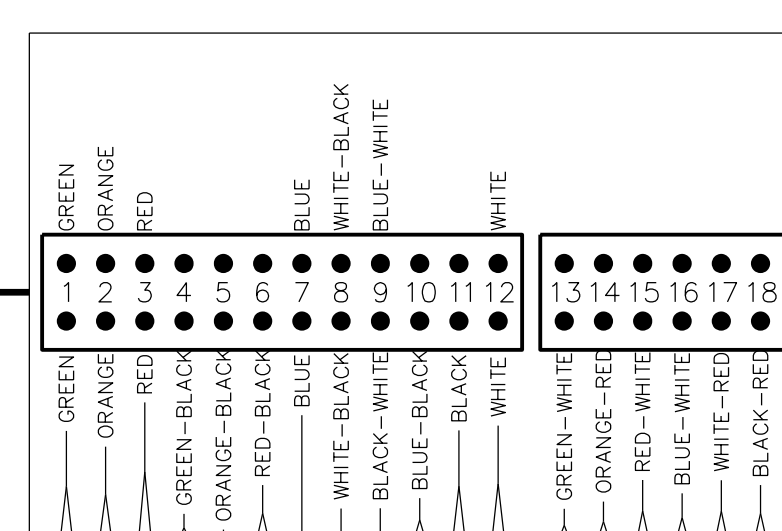
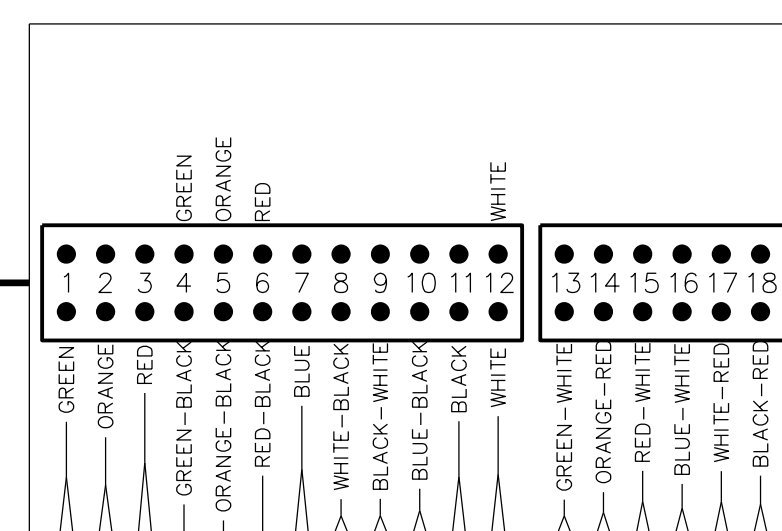
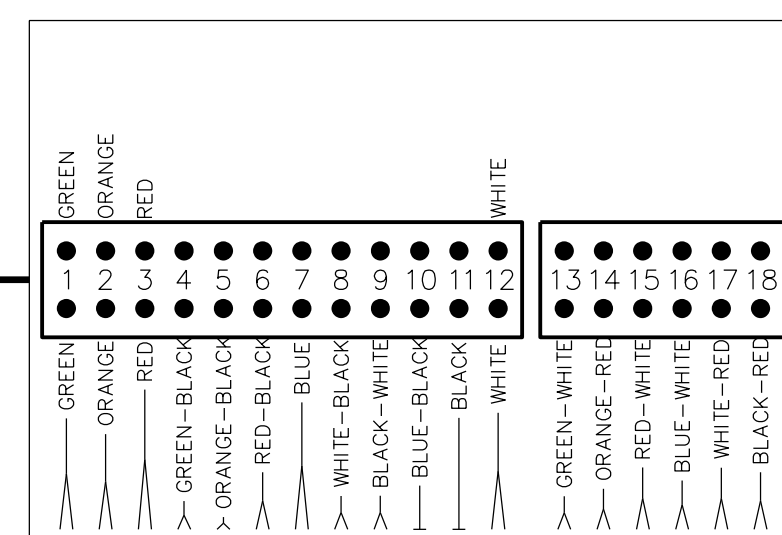
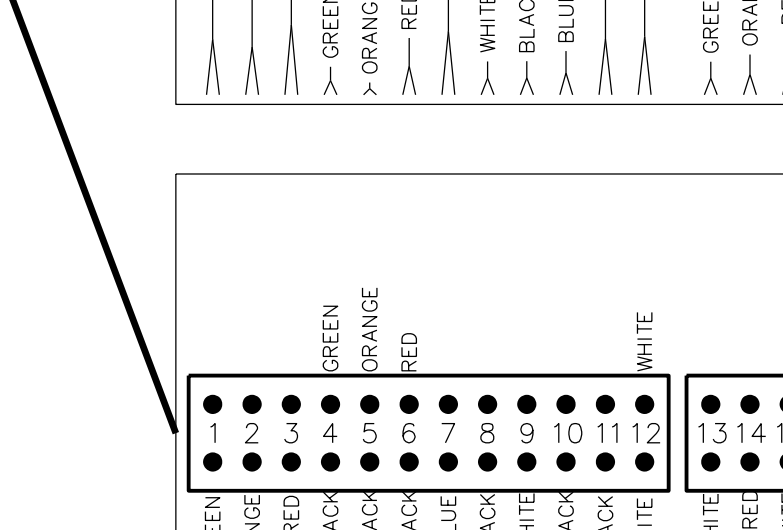
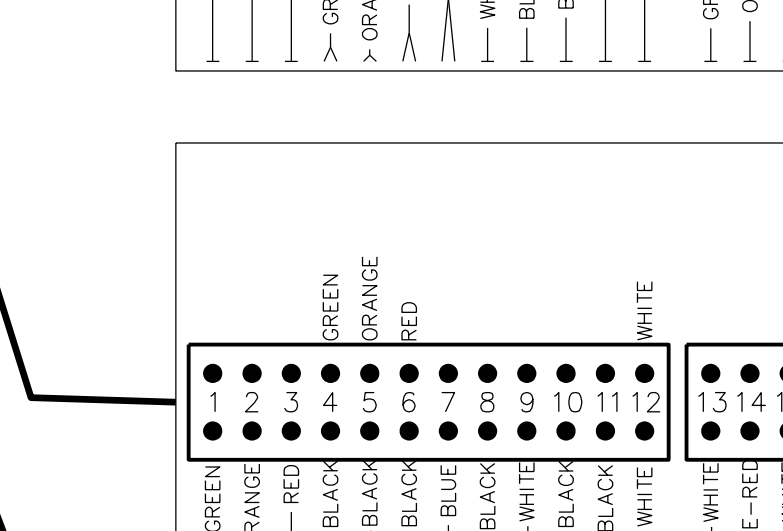
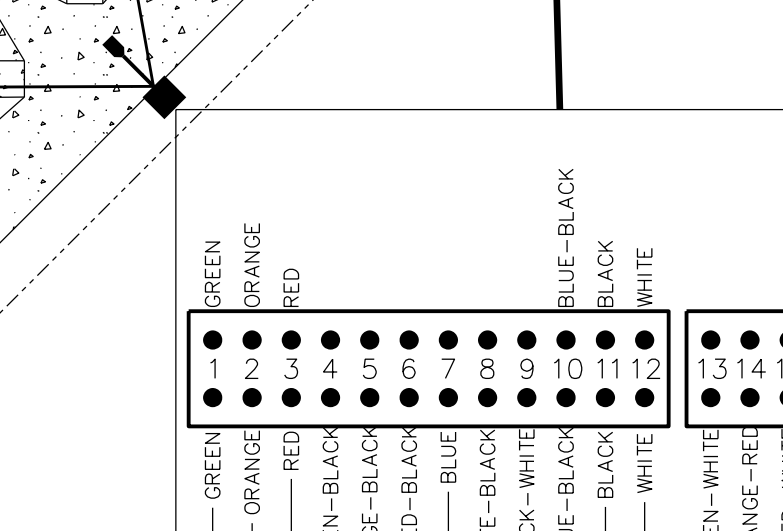
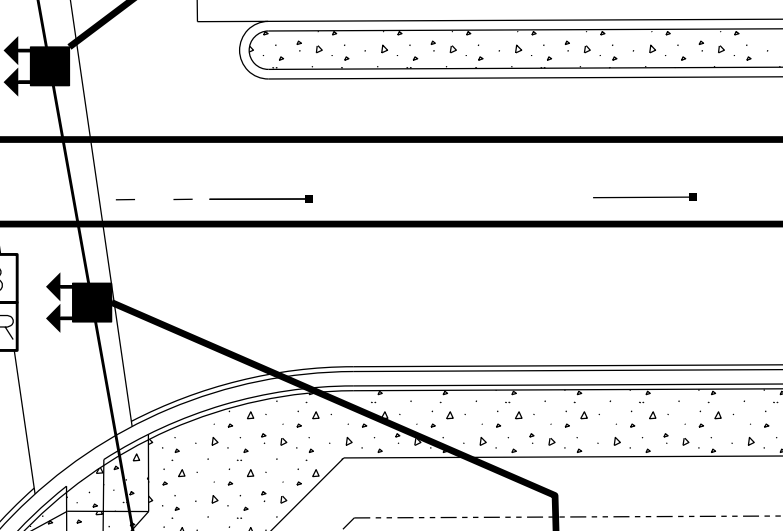
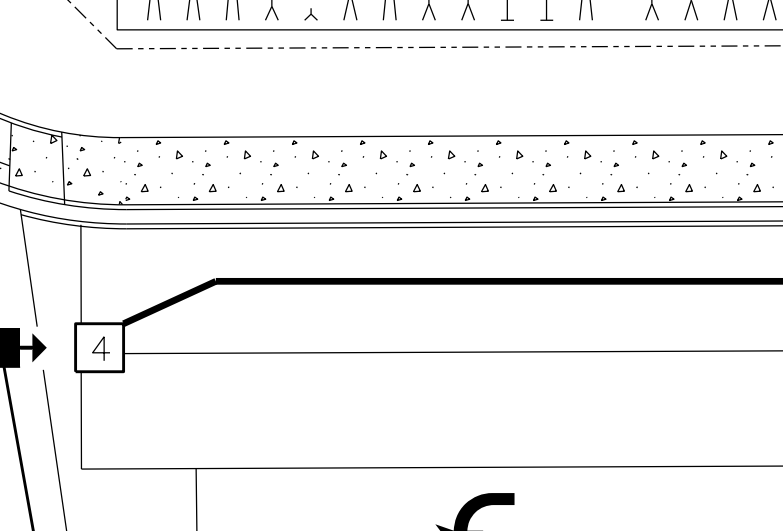
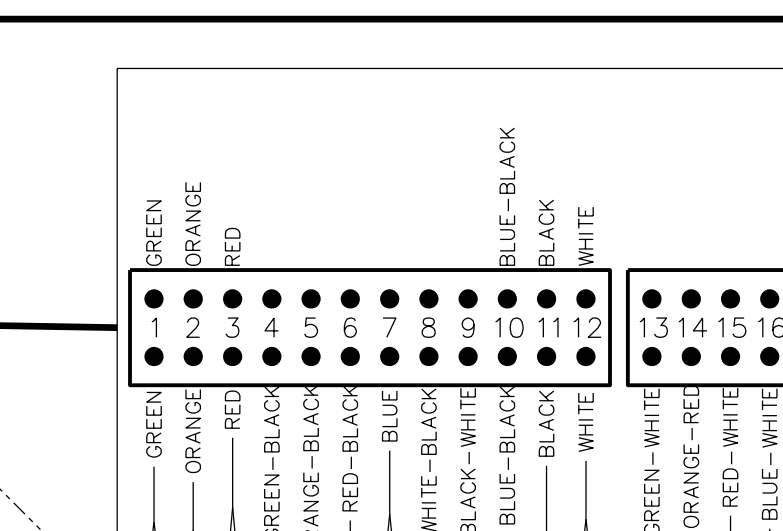
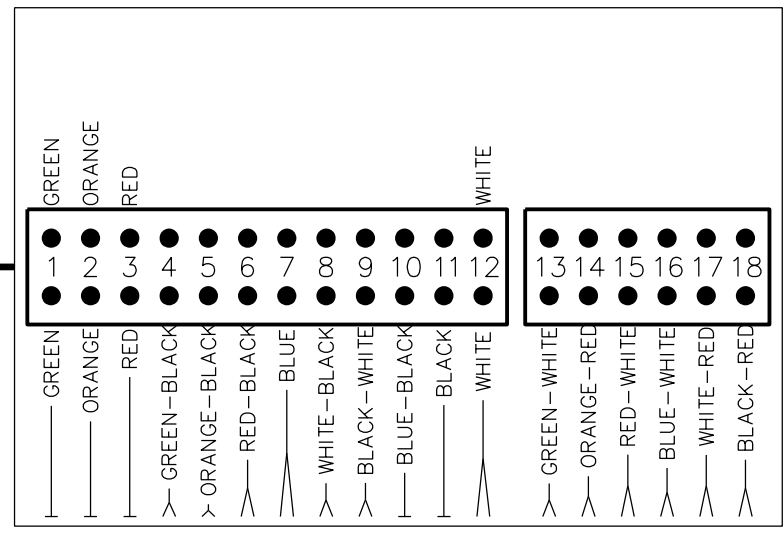
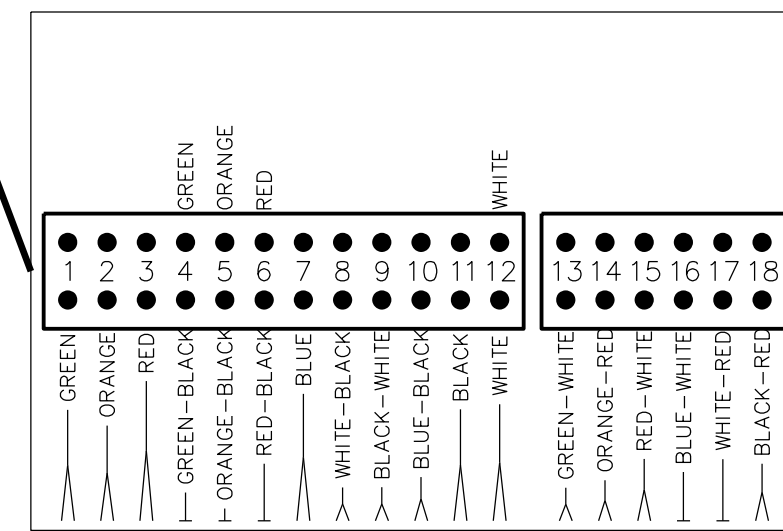
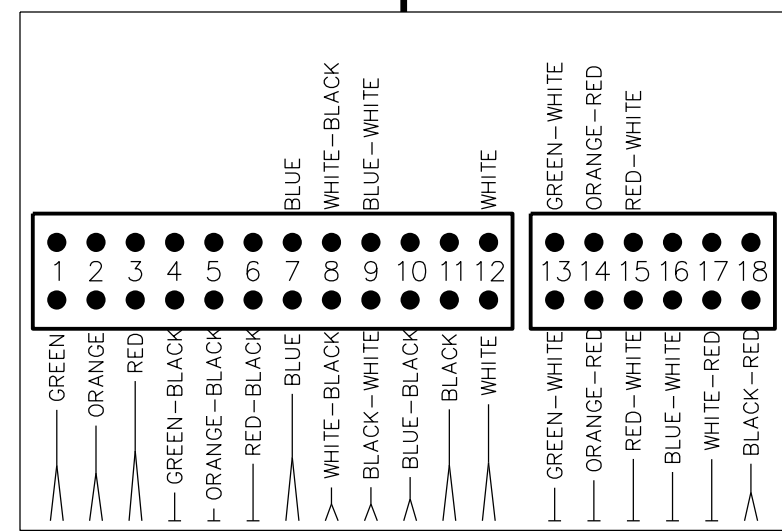
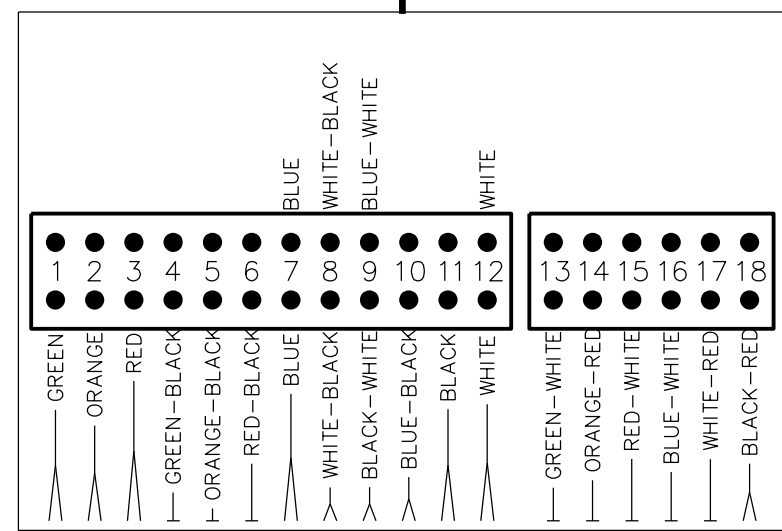
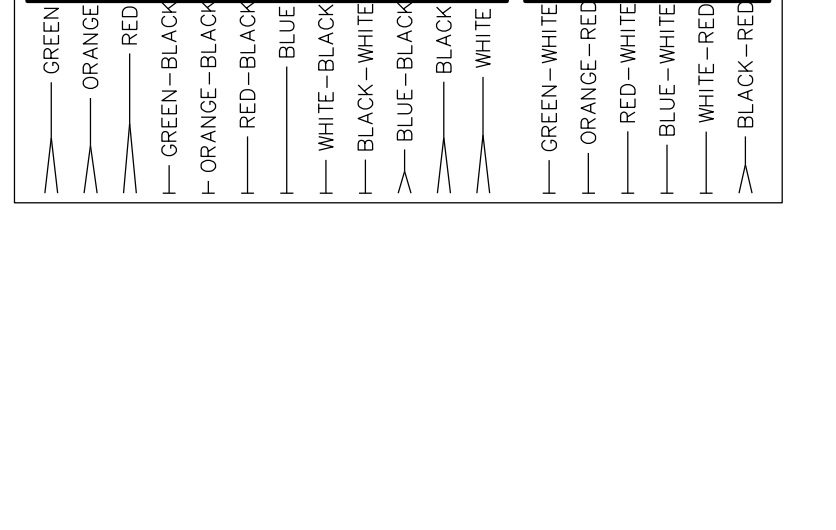
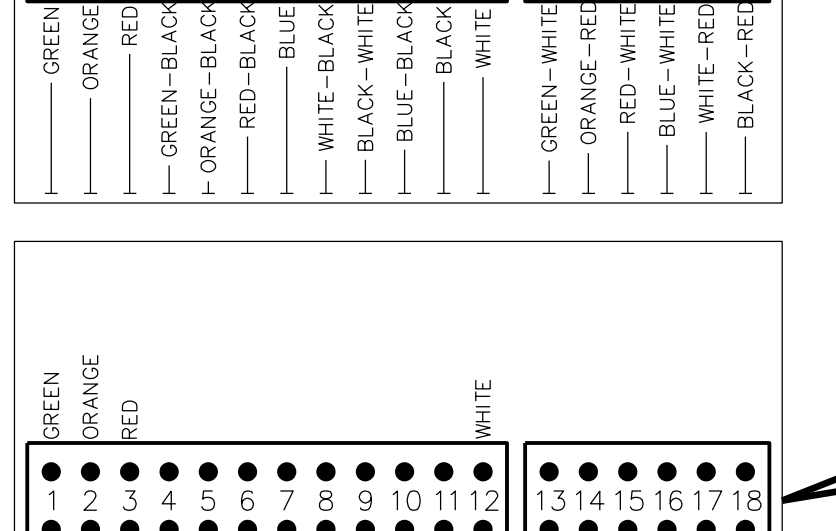
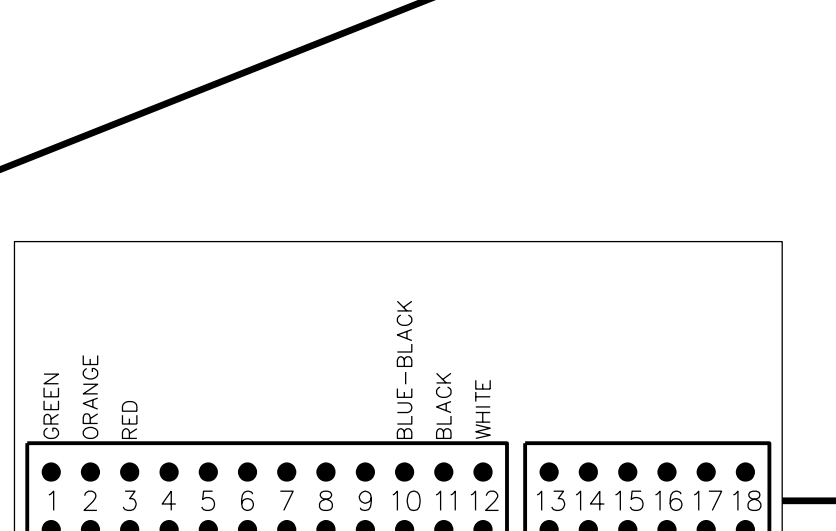
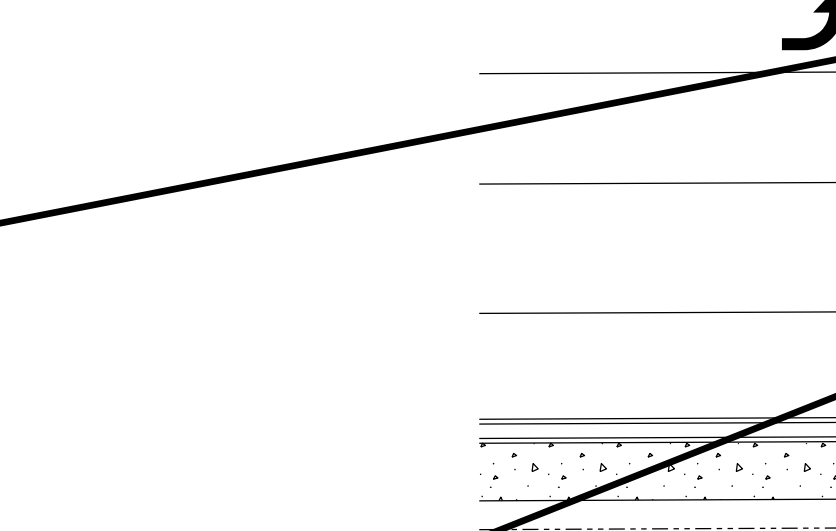
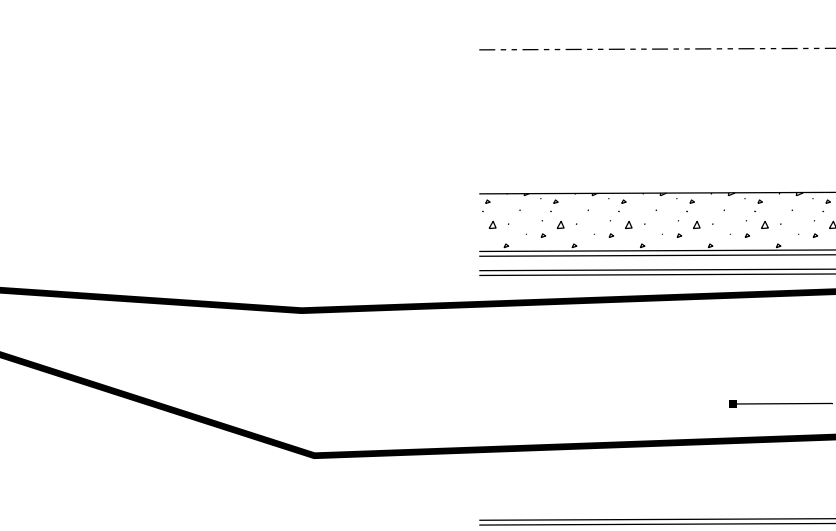
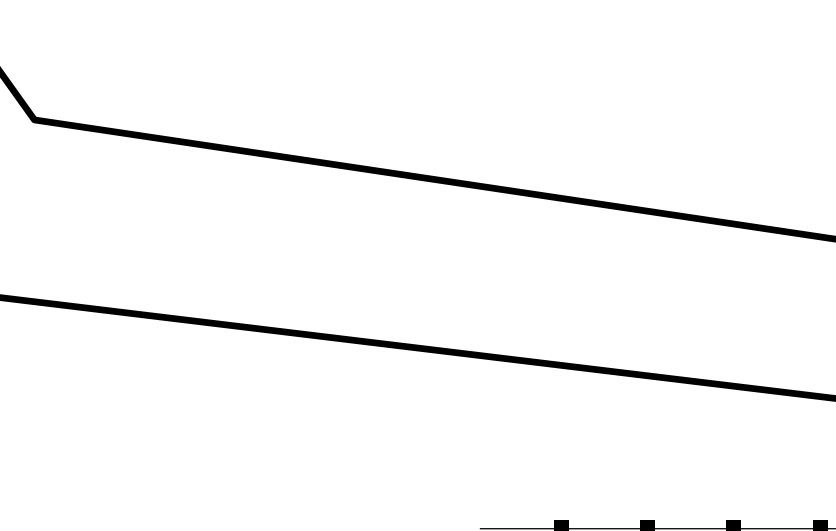
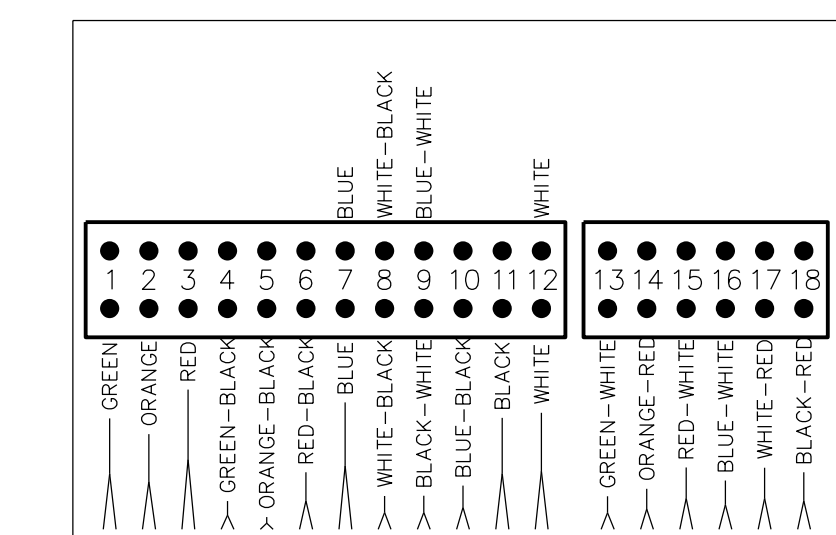
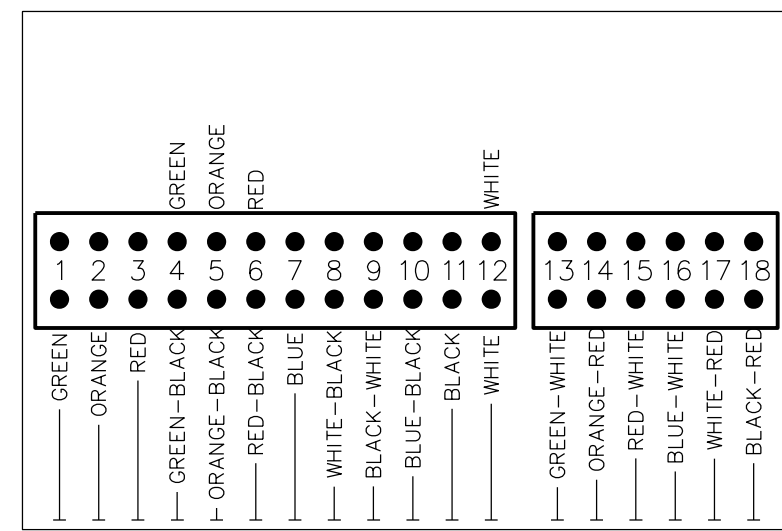
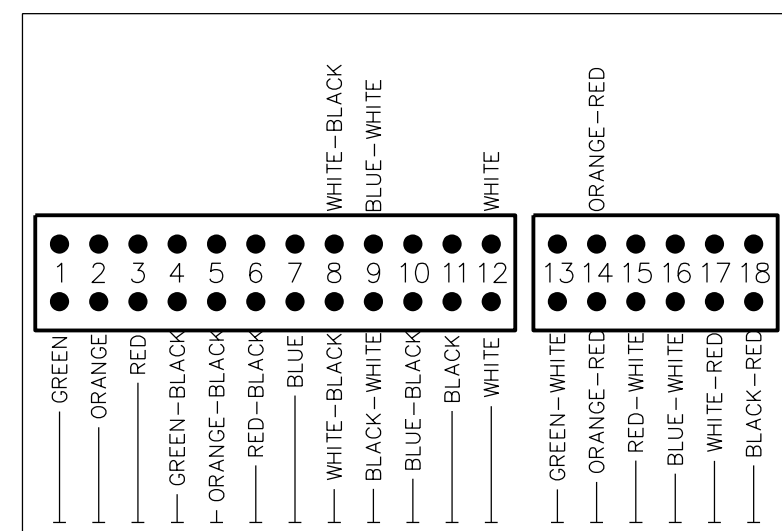
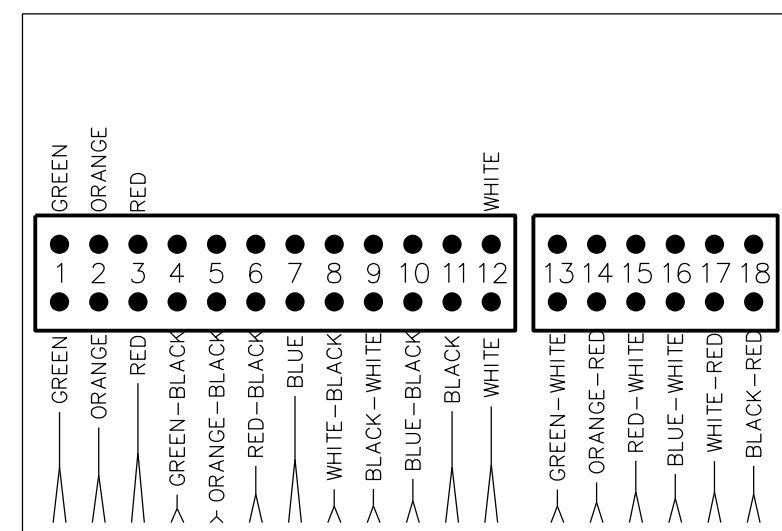
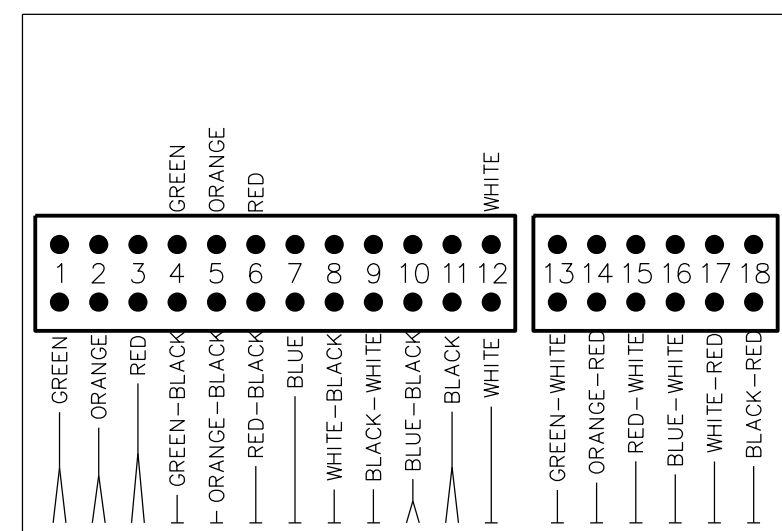
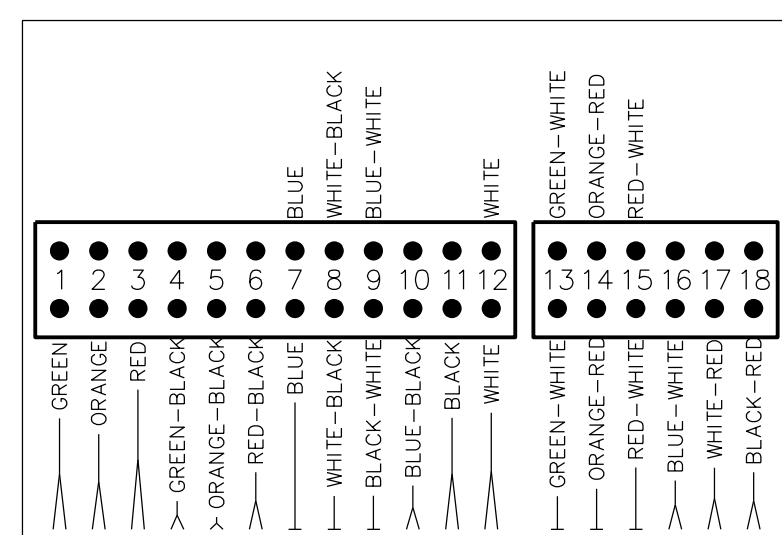

| NO. | DATE | REVISIONS | BY | APP. |
|---|------|----------------|--------------|------|
| GENERAL NOTES: | | | | |
| 1. THIS DRAWING IS NOT TO SCALE. | | | | |
| 2. DESIGN, LAYOUT & DATA ON THIS SHEET ARE FOR ILLUSTRATION PURPOSE ONLY. | | | | |
| PALM BEACH COUNTY, FLORIDA TRAFFIC DIVISION | | | | |
| SIGNAL TYPICAL | | | | |
| SPAN WIRE DISCONNECT WIRING DIAGRAM PER SIGNAL HEAD | | | | |
| SIGNATURE | | DATE | | |
| <i>Fateme N. Jafar</i> | | | | |
| DRAWN BY | | SCALE | CONTRACT NO. | |
| CHECKED BY | | * N. T. S. | | |
| DRAWING T-5.5 | | SHEET 10 OF 28 | | |

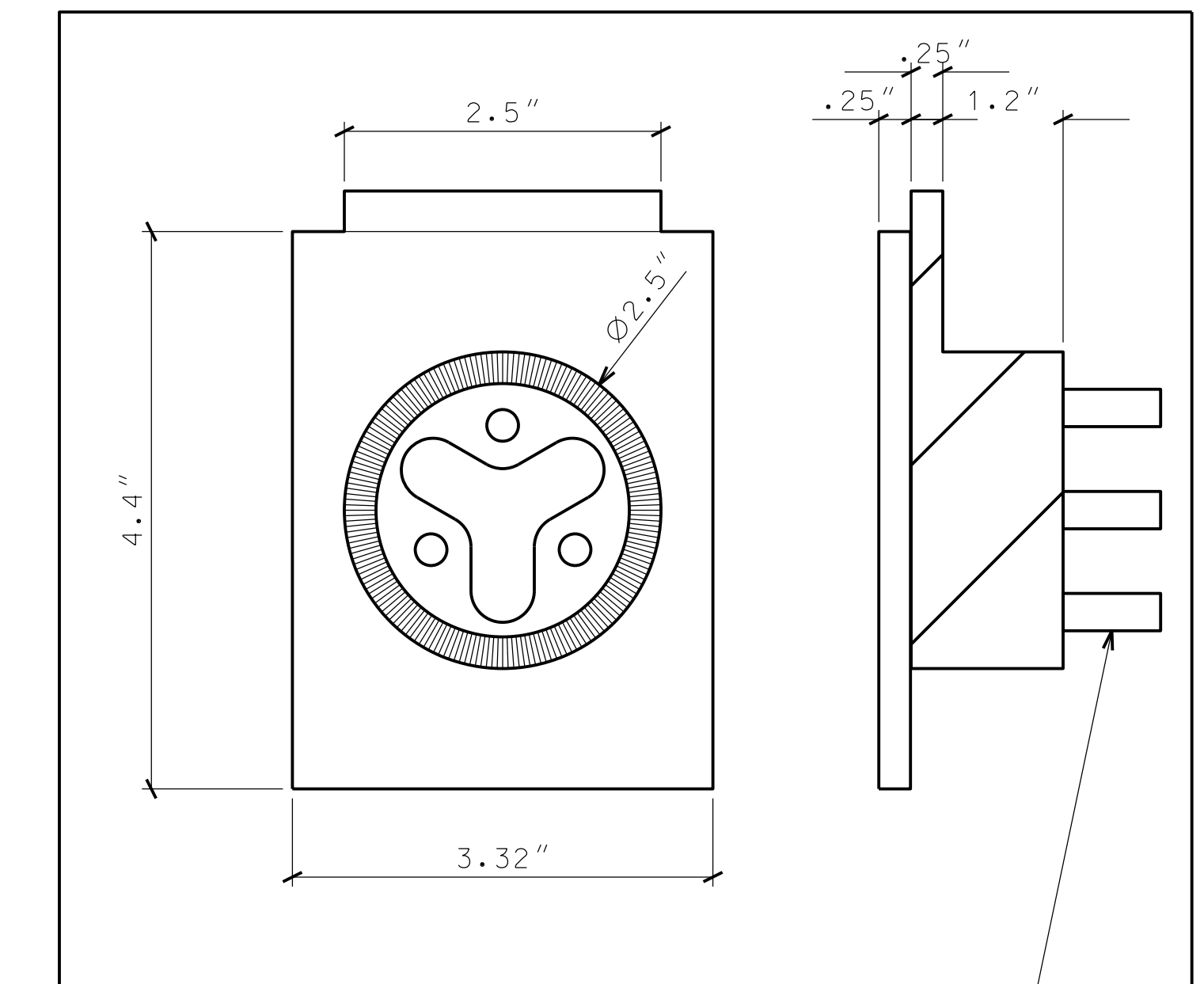
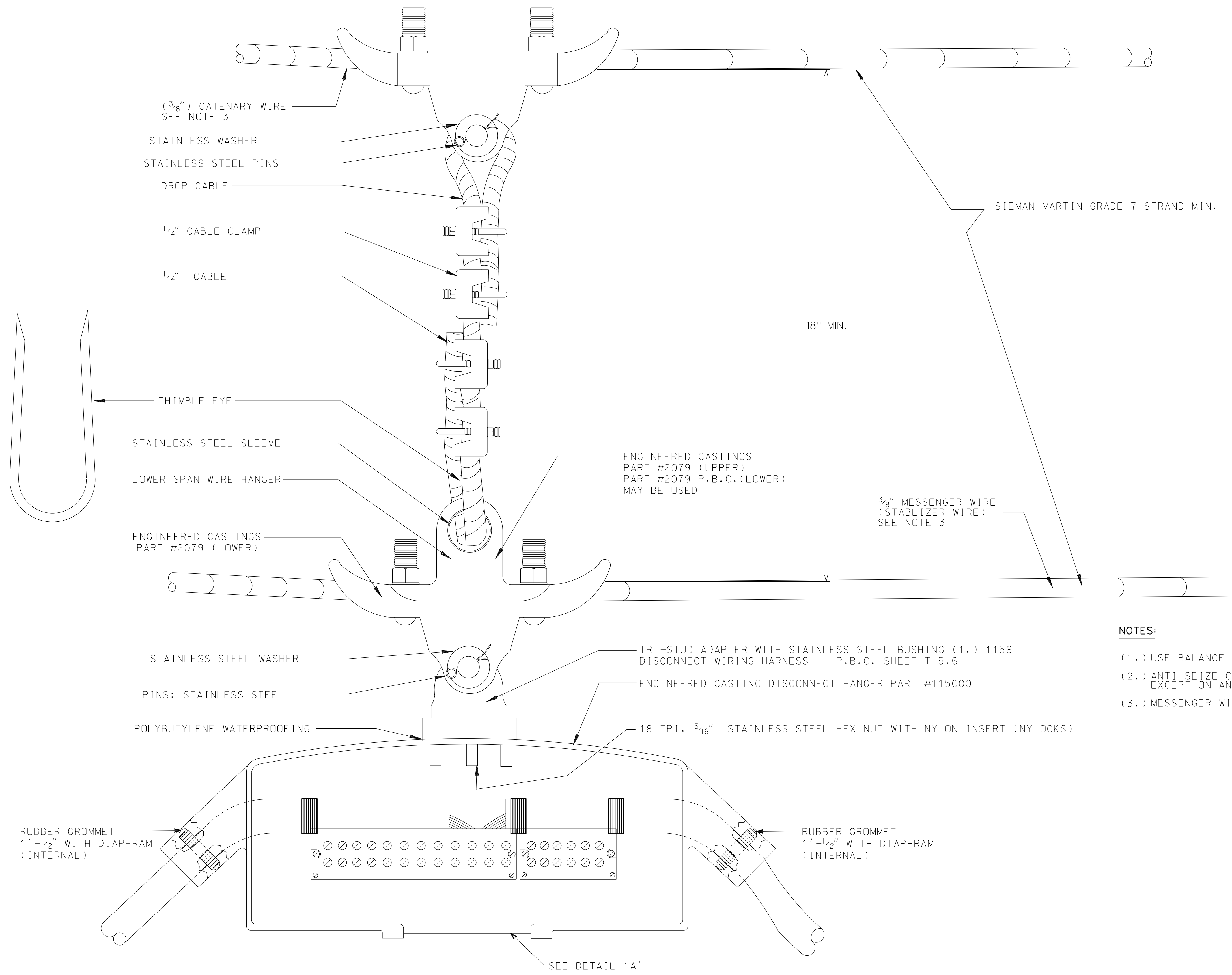

DETAIL 'A'

- NOTES:**
- (1.) USE BALANCE ARM ADJUSTER (CHTL 2357 TYPE) AS ALTERNATE.
 - (2.) ANTI-SEIZE COMPOUND TO BE USED ON ALL CONNECTIONS EXCEPT ON ANY NYLON MATERIALS.
 - (3.) MESSENGER WIRE SIZE MAY VARY AS DETERMINED BY ENGINEER.

GENERAL NOTES:

- 1. THIS DRAWING IS NOT TO SCALE.
- 2. DESIGN, LAYOUT & DATA ON THIS SHEET ARE FOR ILLUSTRATION PURPOSE ONLY.

**PALM BEACH COUNTY, FLORIDA
TRAFFIC DIVISION
SIGNAL TYPICAL**

MODIFICATION TO SPAN WIRE
INSTALLATION DETAIL OF
FDOT STANDARD INDEX 17727

SIGNATURE: *Fatme N. Jafar* DATE: _____ FATMEH N. JAFAR
ENGINEER OF RECORD
DRAWN BY: _____ NAME: _____ DATE: _____ SCALE: _____ CONTRACT NO.: _____
CHECKED BY: _____ N. T. S.

| NO. | DATE | REVISIONS | BY | APP. |
|-----|------|-----------|----|------|
| | | | | |

DRAWING T-5.6 SHEET 11 OF 28

NOTE:

AFTER TERMINAL BLOCK IS WIRED, THE SIGNAL CABLE IS TO BE SECURED TO BLOCK WITH TIE WRAPS (MIN. OF 2).

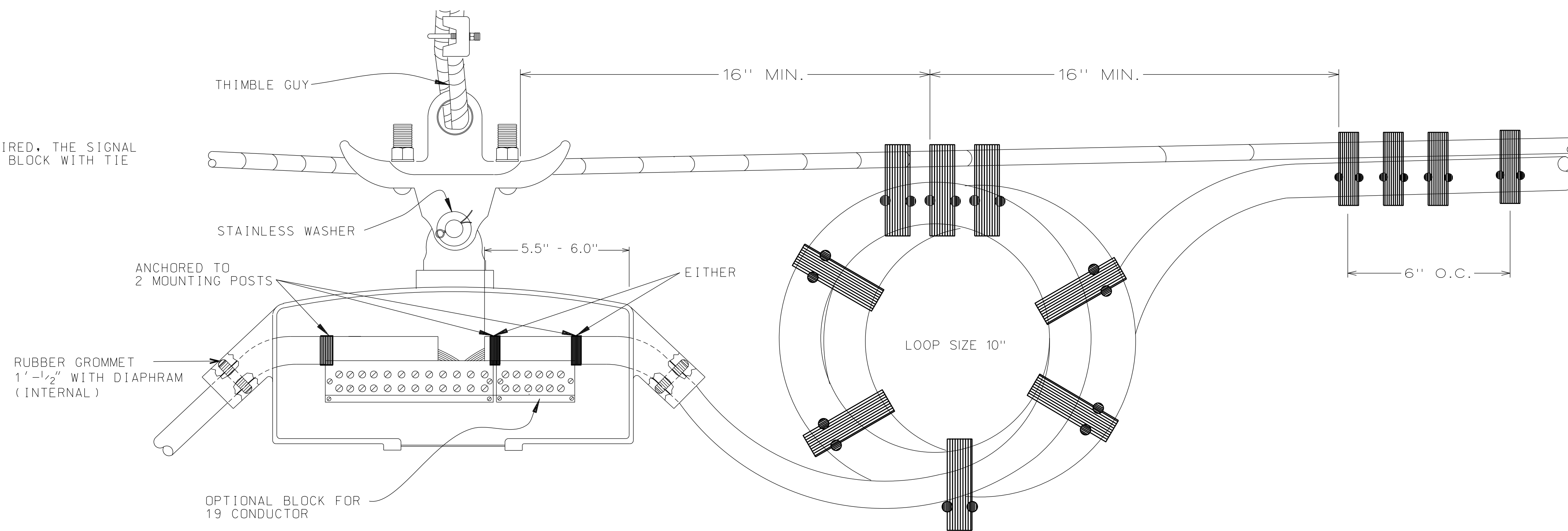

SIGNAL CABLE TIE-WRAP

1. DRIP LOOP TO BE TIE-WRAPPED WITH PANDUIT #BT2LH-TLO (OR EQUAL)

CONDUCTOR COLOR CODE AND SEQUENCE CHART

| CONDUCTOR | DISCONNECT WIRING BASE COLOR/TRACER | | CONDUCTOR | DISCONNECT WIRING FOR OPTIONAL BLOCK BASE COLOR/TRACER | |
|-----------|--|-------|-----------|---|-------|
| 1 | GREEN | — | 13 | GREEN | WHITE |
| 2 | ORANGE | — | 14 | ORANGE | RED |
| 3 | RED | — | 15 | RED | WHITE |
| 4 | GREEN | BLACK | 16 | BLUE | WHITE |
| 5 | ORANGE | BLACK | 17 | WHITE | RED |
| 6 | RED | BLACK | 18 | BLACK | RED |
| 7 | BLUE | — | | | |
| 8 | WHITE | BLACK | | | |
| 9 | BLACK | WHITE | | | |
| 10 | BLUE | BLACK | | | |
| 11 | BLACK | — | | | |
| 12 | WHITE | — | | | |

WIRE: #14 THHN, 19 STRAND COPPER, NYLON COATED PVC INSULATION, GAS & OIL RESISTANT.

GENERAL NOTES:
 1. THIS DRAWING IS NOT TO SCALE.
 2. DESIGN, LAYOUT & DATA ON THIS SHEET ARE FOR ILLUSTRATION PURPOSE ONLY.

**PALM BEACH COUNTY, FLORIDA
 TRAFFIC DIVISION
 SIGNAL TYPICAL**

**DISCONNECT WITH DOUBLE
 DRIP LOOP SIGNAL HEAD**

SIGNATURE: *Fatme N. Jafar* DATE: _____ FATMEH N. JAFAR
 ENGINEER OF RECORD
 DRAWN BY: _____ NAME: _____ DATE: _____ SCALE: _____ CONTRACT NO. _____
 CHECKED BY: _____ * N. T. S.

| NO. | DATE | REVISIONS | BY | APP. |
|-----|------|-----------|----|------|
| | | | | |

DRAWING T-5.7 SHEET 12 OF 28

ASSOCIATED PHASE MOVEMENTS

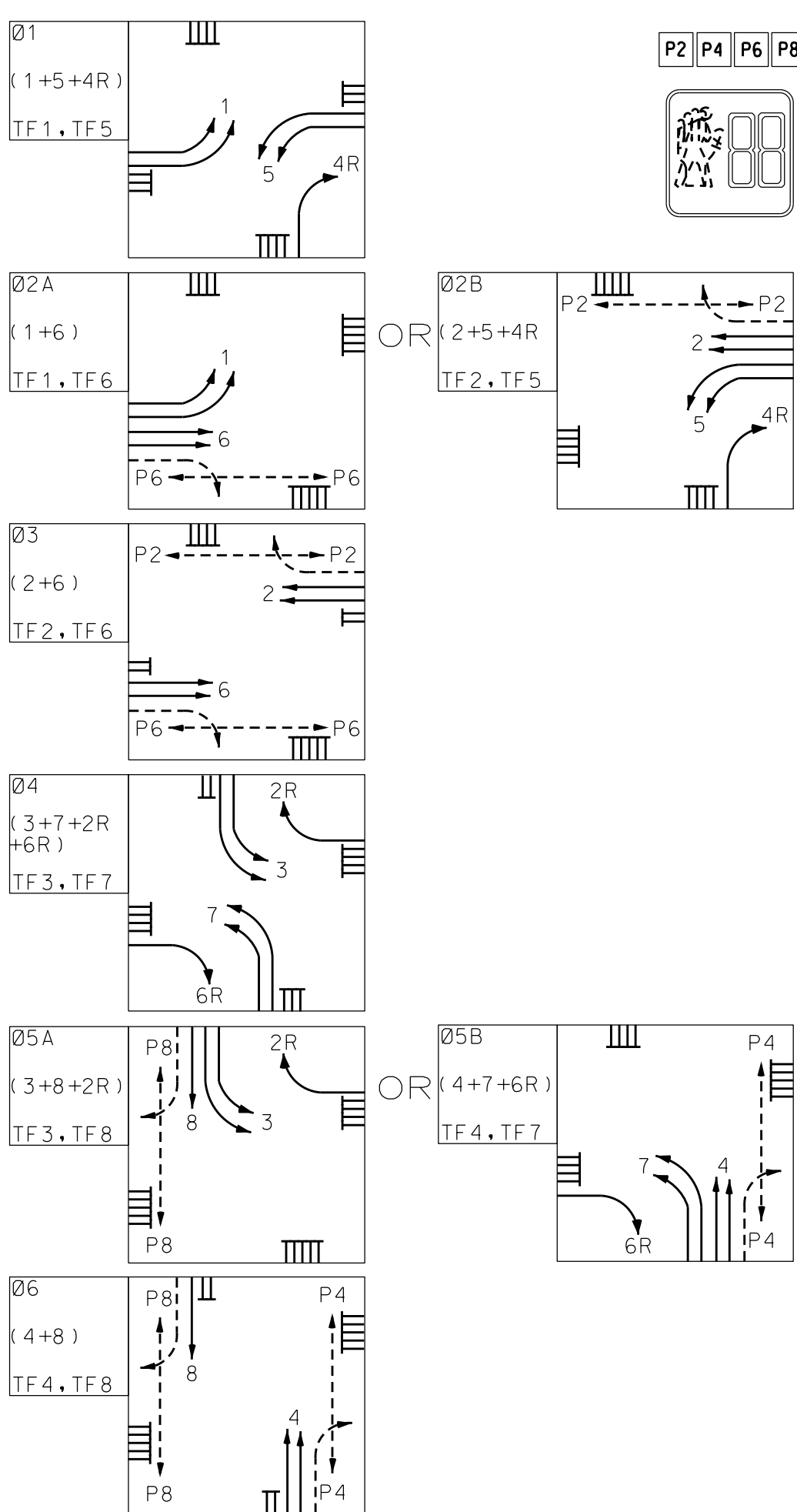

DETAIL OF SIGNAL HEADS

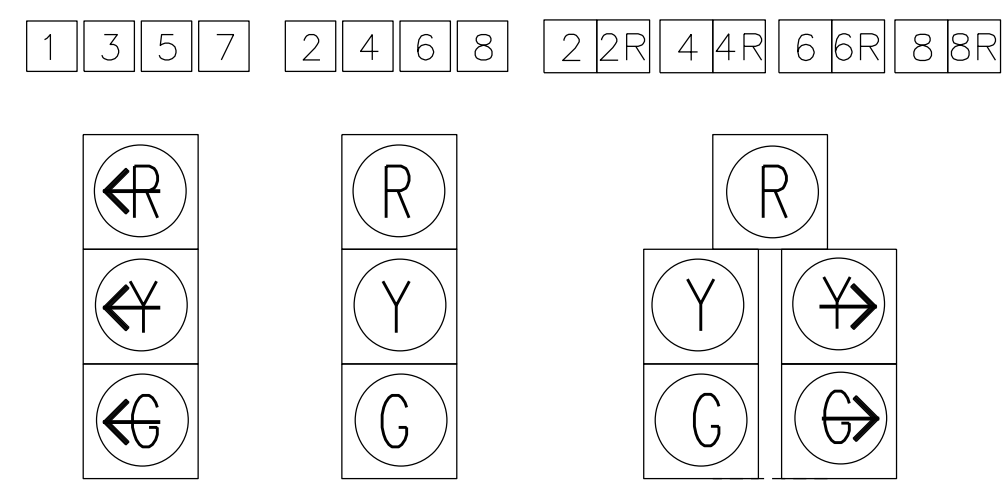

DETAIL OF SIGNS

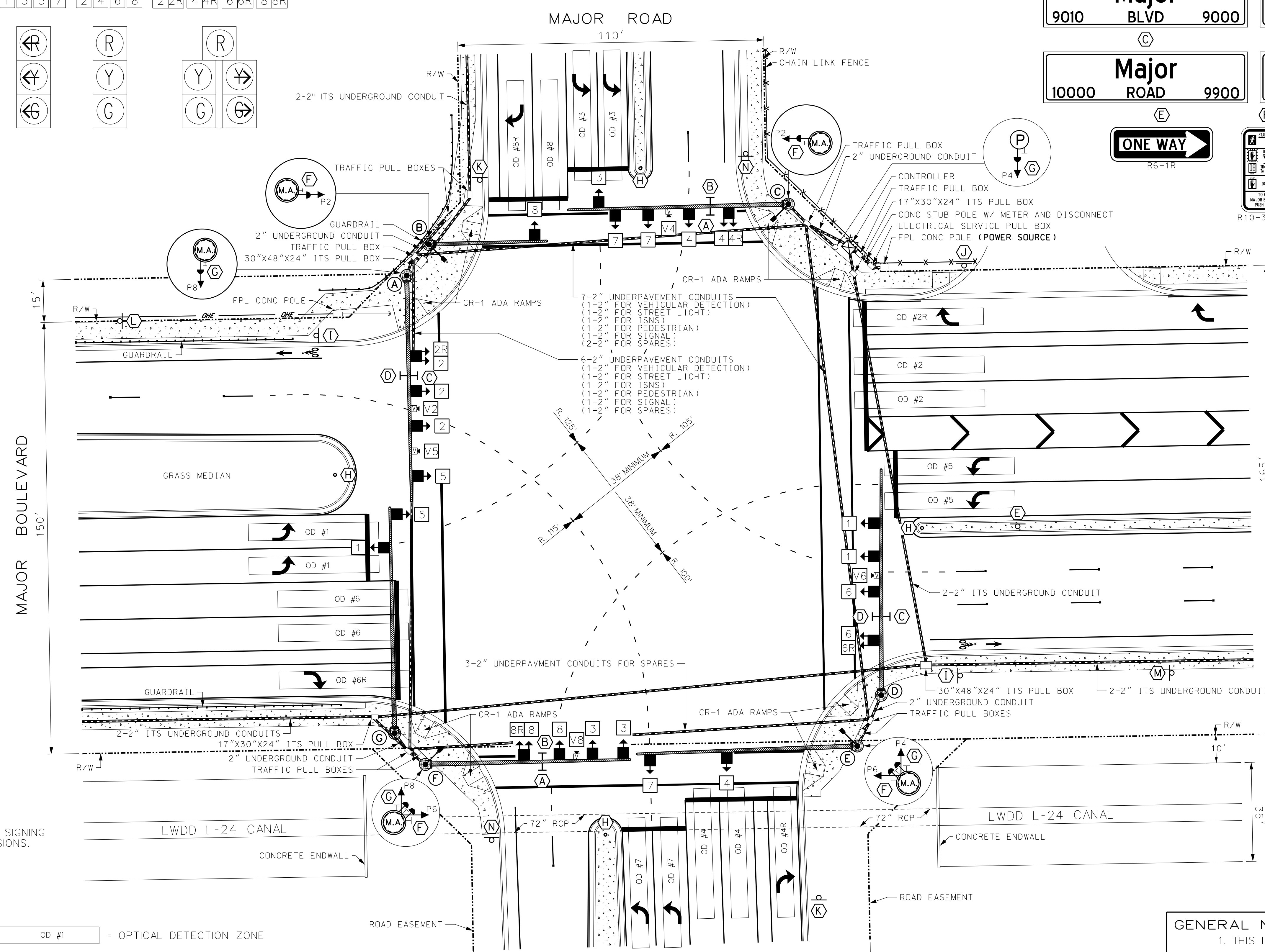
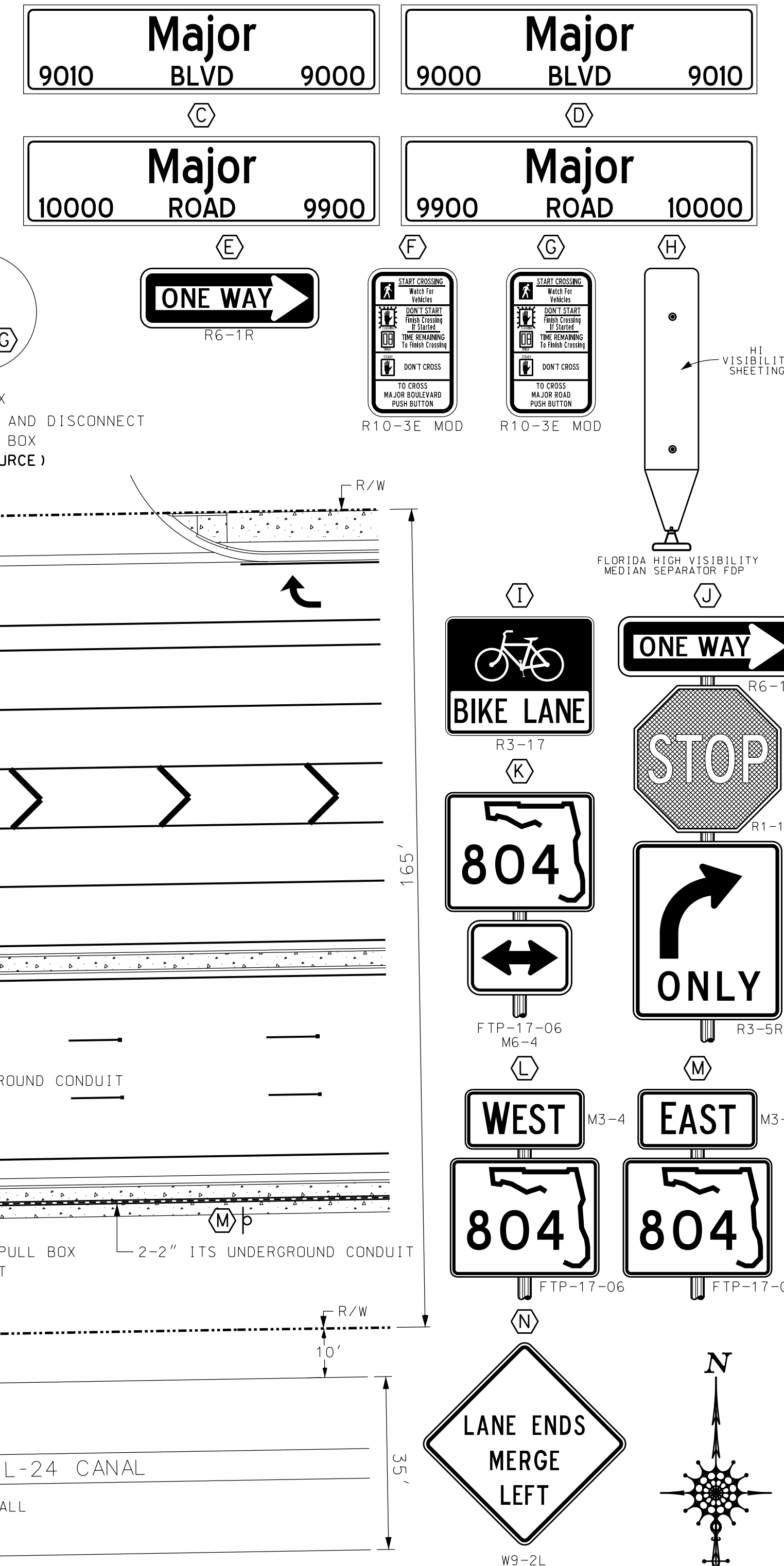

DESIGN NOTES:

- LUMINAIRE LOCATIONS: NE, NW, SE, SW (PBC) (LED)
- FLASHING OPERATION: ALL RED
- SPEED LIMITS: MAJOR ROAD - 45 MPH, MAJOR BLVD - 45 MPH
- SIGNS "A", "B", "C" AND "D" ARE INTERNALLY ILLUMINATED (ISNS)

NOTE: REFER TO PBC TYPICALS FOR PAVEMENT MARKINGS, SIGNING AND GEOMETRICS FOR STRIPING DETAILS AND DIMENSIONS.

GENERAL NOTES:

- THIS DRAWING IS NOT TO SCALE.
- DESIGN, LAYOUT & DATA ON THIS SHEET ARE FOR ILLUSTRATION PURPOSE ONLY.

PALM BEACH COUNTY, FLORIDA
TRAFFIC DIVISION
SIGNAL TYPICAL

TYPICAL MAST ARM SIGNAL OPERATION AND INSTALLATION

SIGNATURE: *Fatme N. Jafar* DATE: _____ FATMEH N. JAFAR
ENGINEER OF RECORD
DRAWN BY: _____ SCALE: _____ CONTRACT NO. _____
CHECKED BY: _____ N. T. S.

| MAST ARM DATA | | | | | | | |
|---------------|---------------|----------------------------|------------|--------------|-------------------------|-----------|-------|
| I.D. NO. | ASSEMBLY TYPE | LOCATION BY STATION/CORNER | ARM LENGTH | MOUNT HEIGHT | ANGLE BETWEEN DUAL ARMS | LUMINAIRE | COLOR |
| A | A78-P6/S | NORTH-WEST | 78' | 20' | - | NO | GALV |
| B | A40-P2/S/L | NORTH-WEST | 40' | 20' | - | YES | GALV |
| C | A78-P6/S/L | NORTH-EAST | 76' | 20' | - | YES | GALV |
| D | A78-P6/S | SOUTH-EAST | 78' | 20' | - | NO | GALV |
| E | A78-P6/S/L | SOUTH-EAST | 76' | 20' | - | YES | GALV |
| F | A70-P5/S/L | SOUTH-WEST | 70' | 20' | - | YES | GALV |
| G | A70-P5/S | SOUTH-WEST | 70' | 20' | - | NO | GALV |

| VIDEO DETECTOR CONNECTION | | | |
|---------------------------|-----------|-----------|------------------------------|
| DETECTOR UNIT NO. | OPERATION | OD ZONE | CONNECTED TO TIMING FUNCTION |
| 1 | V2 | OD-2,2R | TF2 |
| 2 | V4 | OD-4,4R,7 | TF4,7 |
| 3 | V6 | OD-6,6R,1 | TF1,6 |
| 4 | V8 | OD-8,8R,3 | TF3,8 |
| 5 | V5 | OD-5 | TF5 |

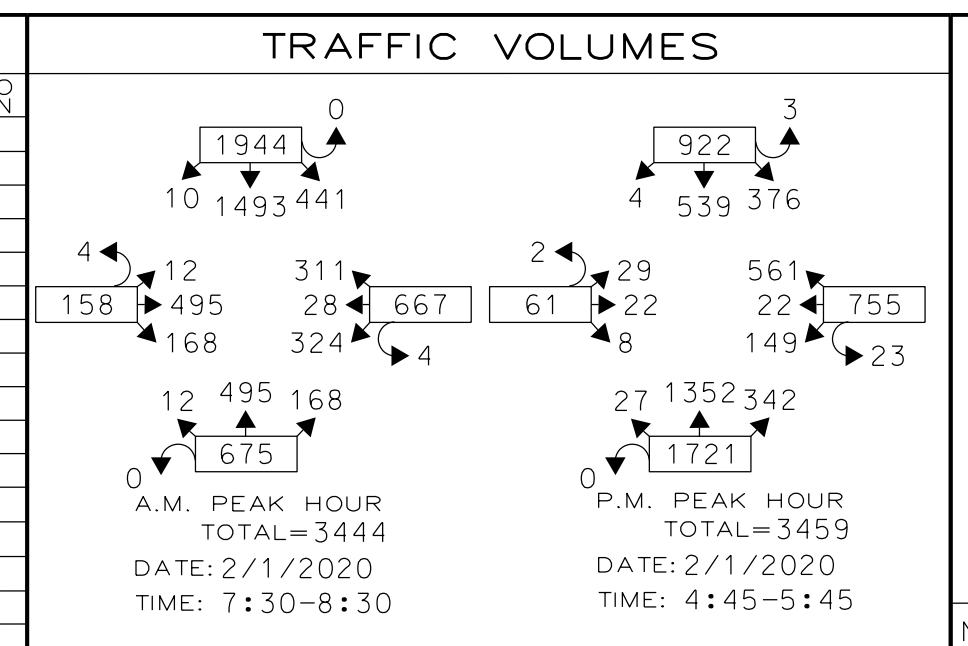

| NO. | DATE | REVISIONS | BY | APP. | NO. | DATE | REVISIONS | BY | APP. |
|-----|------|-----------|----|------|-----|------|-----------|----|------|
| | | | | | | | | | |

DRAWING T-6 SHEET 13 OF 28

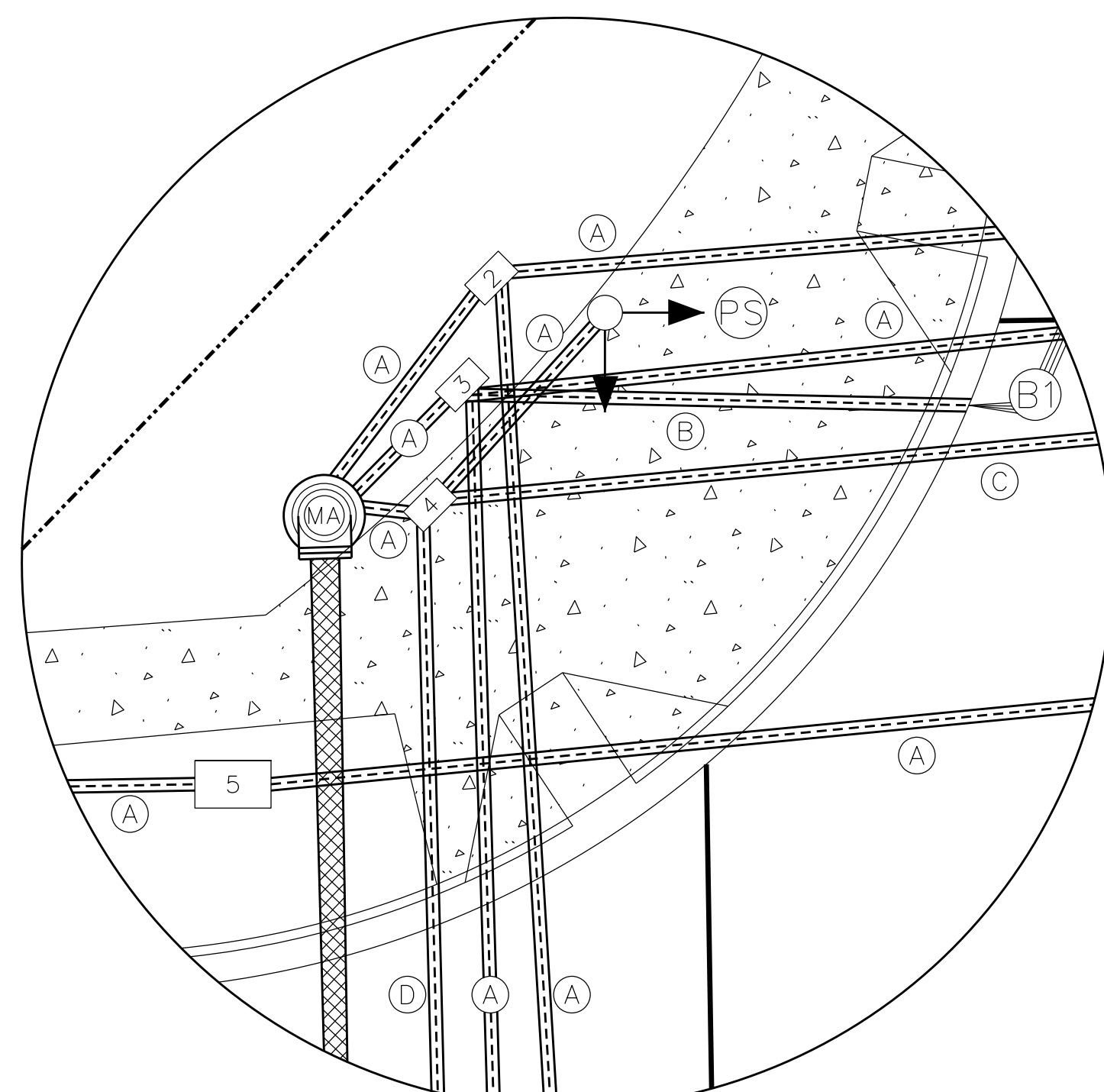

DETAIL "A"

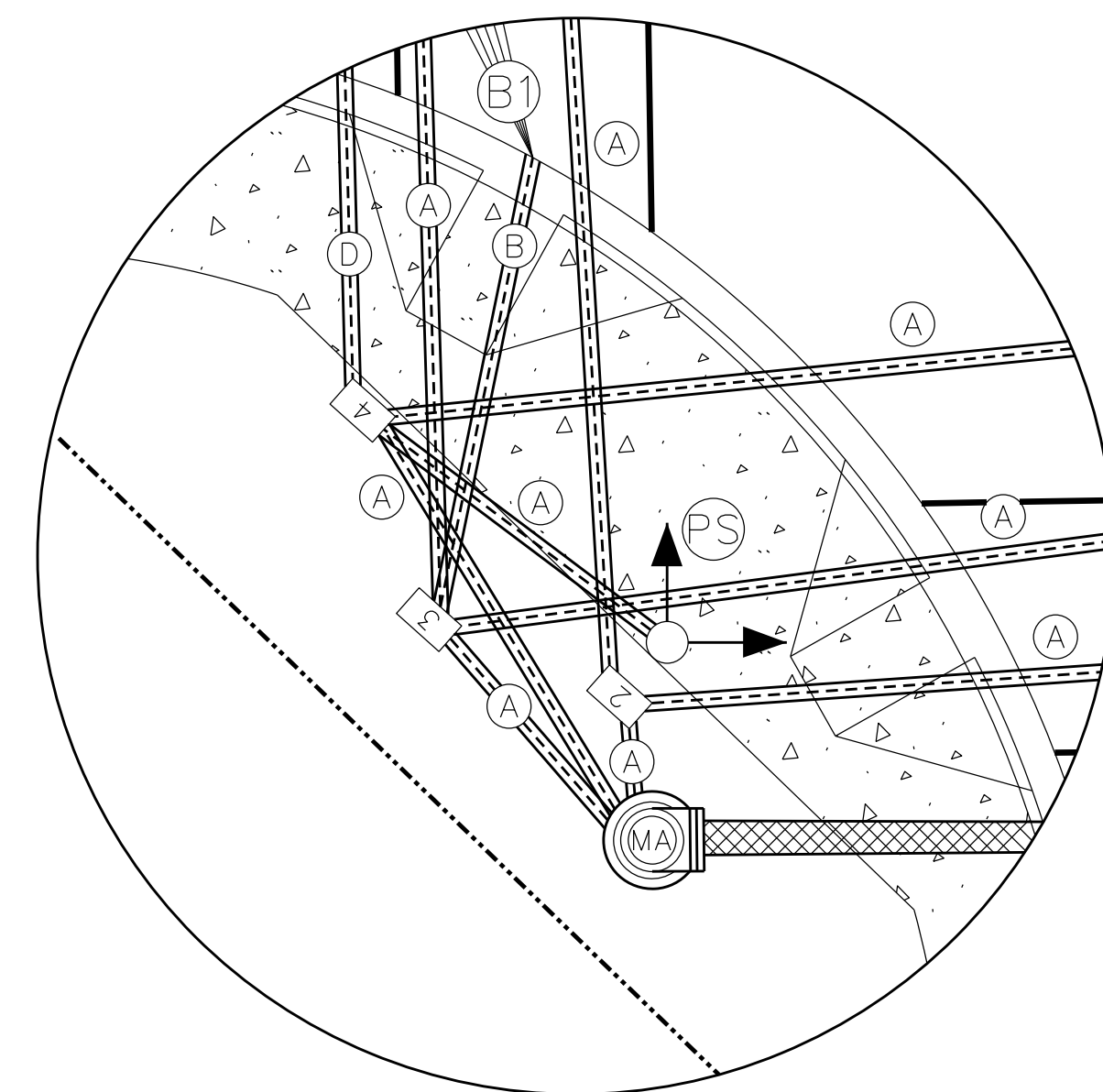

DETAIL "C"

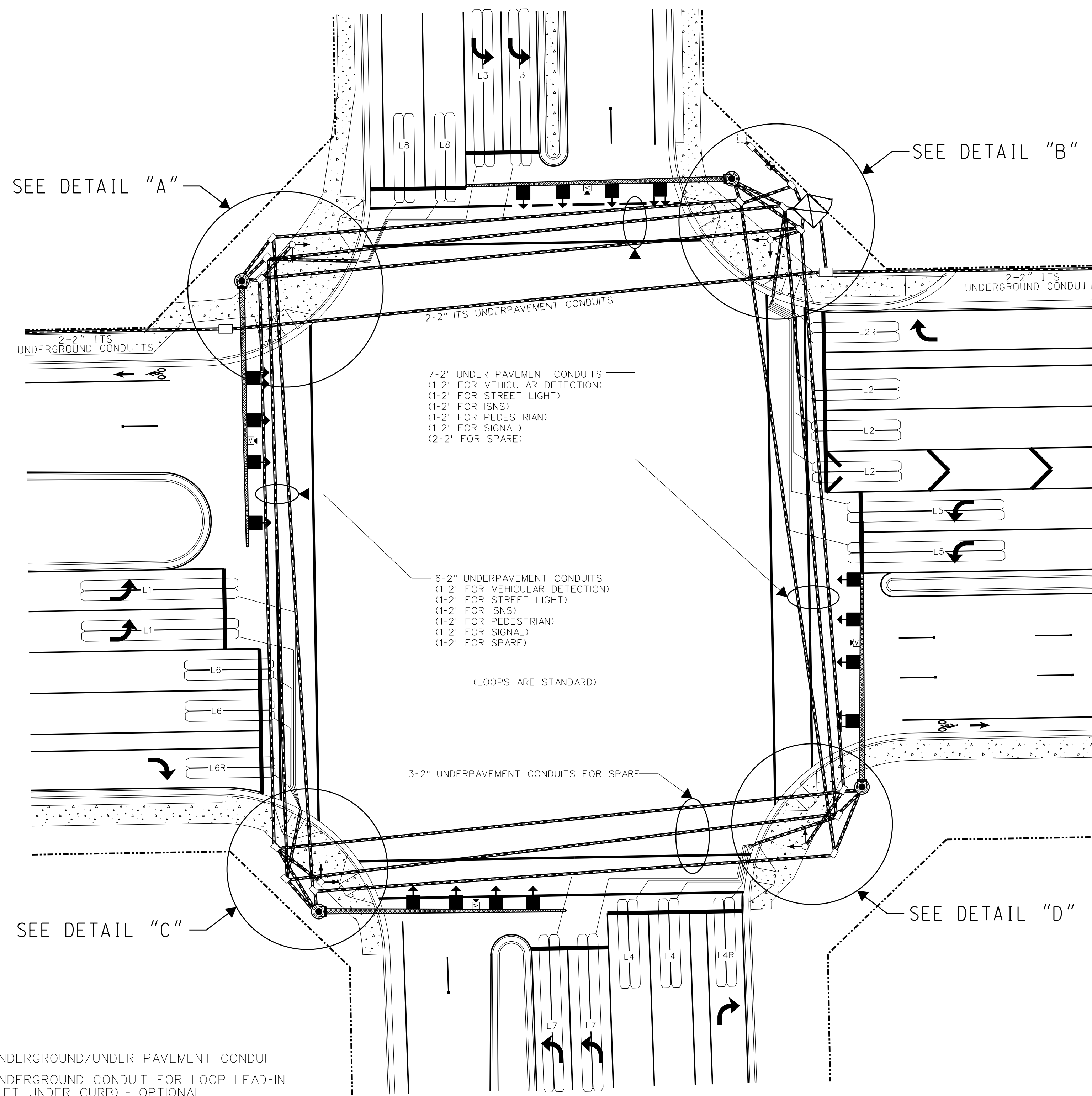

MAJOR ROAD

MAJOR BOULEVARD

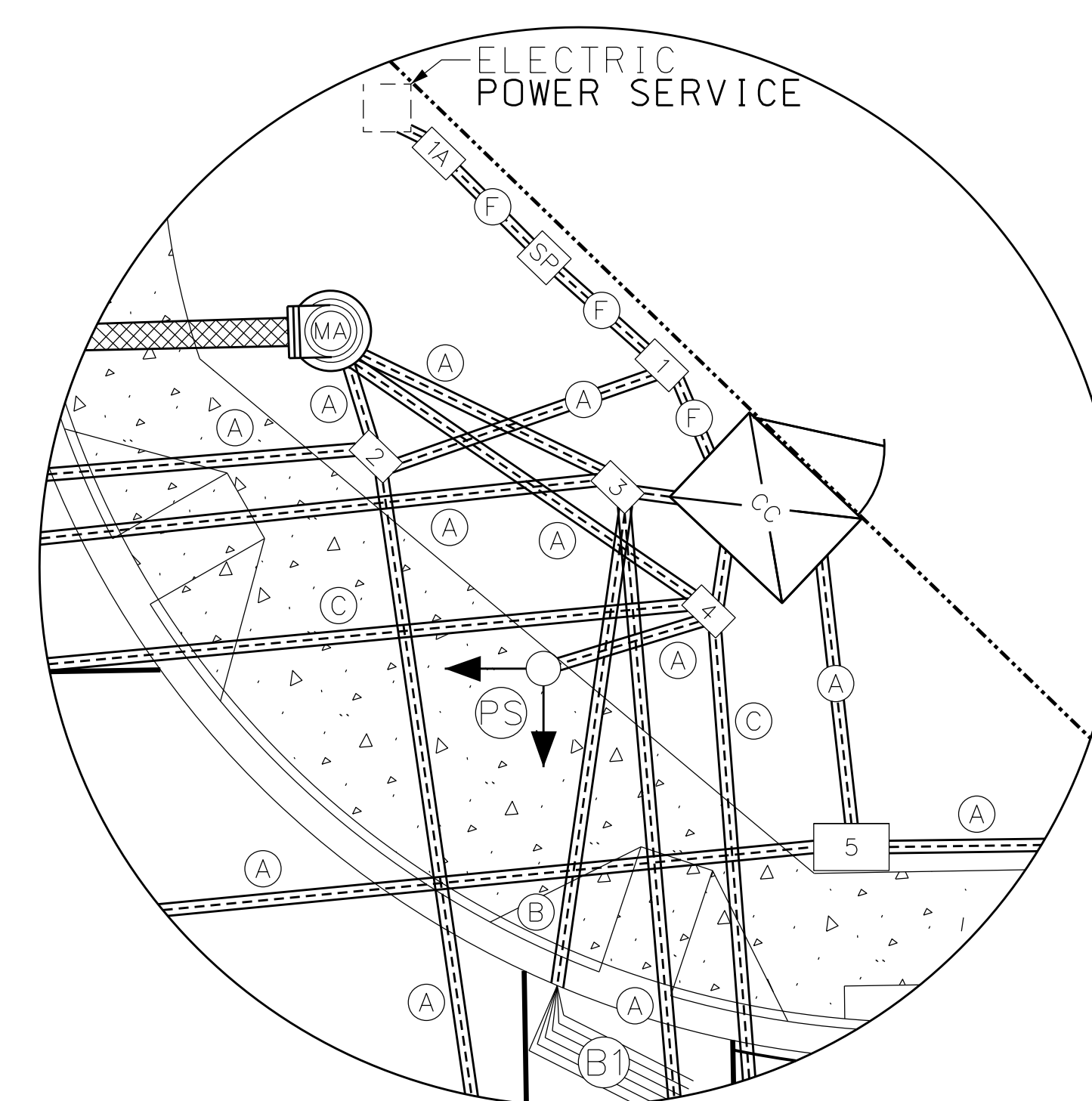

DETAIL "B"

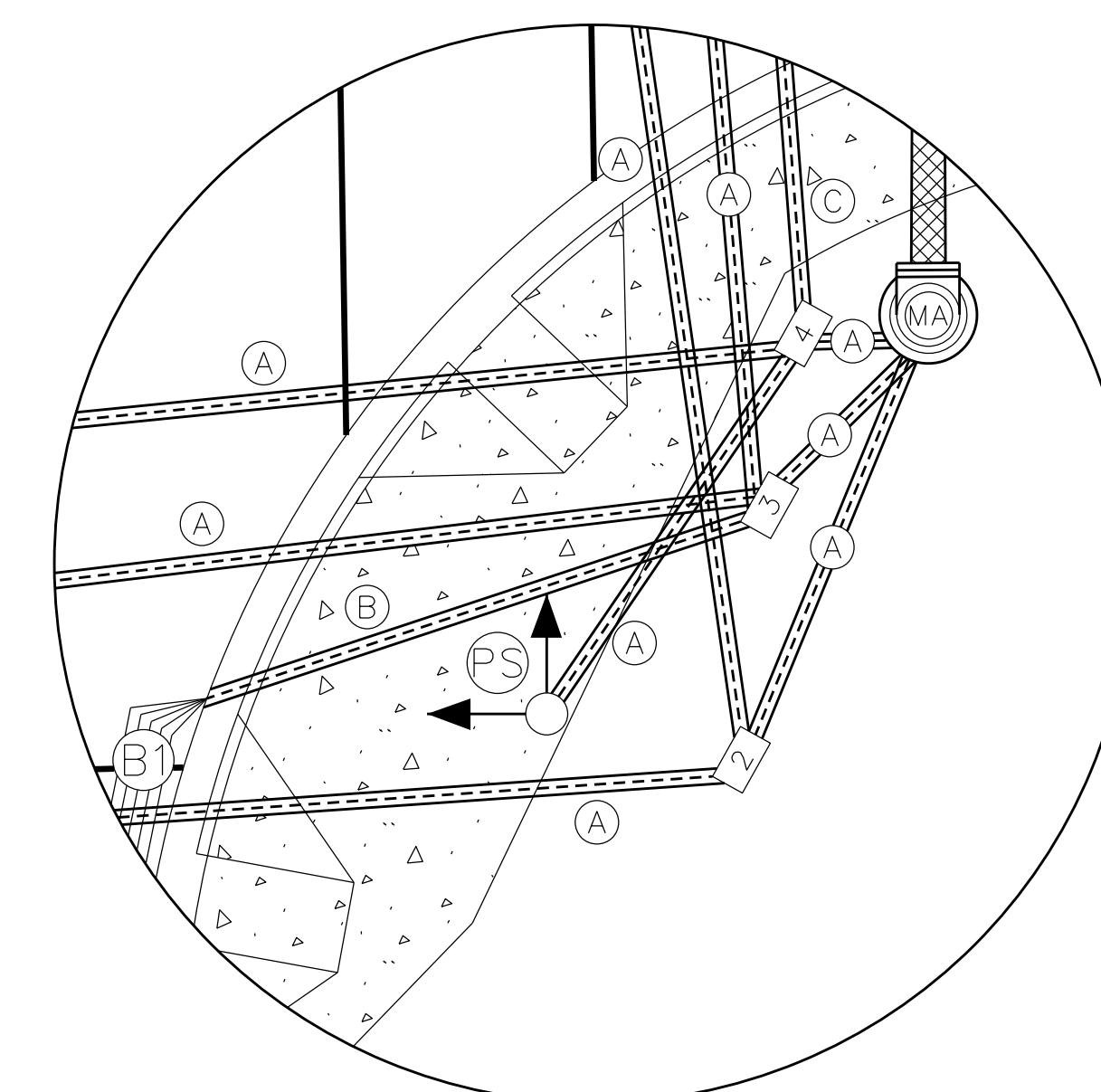

DETAIL "D"

LEGEND

- CC = CONTROLLER CABINET
- MA = MAST ARM
- SP = STUB POLE FOR POWER SERVICE BREAKER BOX
- PS = PEDESTRIAN SIGNAL
- 1 = PULL BOX FOR POWER SERVICE
- 1A = PULL BOX FOR POWER SERVICE - OPTIONAL AS DETERMINED BY ENGINEER
- 2 = PULL BOX FOR STREET LIGHT & ILLUMINATED STREET NAME SIGN
- 3 = PULL BOX FOR VIDEO
- 4 = PULL BOX FOR SIGNAL & PEDESTRIAN CABLE
- 5 = PULL BOX (30X48X24) FOR ITS OPTIONAL SIZE (17X30X24) OR AS DETERMINED BY ENGINEER

- A = 2-2" UNDERGROUND/UNDER PAVEMENT CONDUIT
- B = 2-2" UNDERGROUND CONDUIT FOR LOOP LEAD-IN (PIPE 1 FT UNDER CURB) - OPTIONAL
- B1 = LOOP LEAD-IN - OPTIONAL
- C = 4-2" UNDERGROUND/UNDER PAVEMENT CONDUITS (1-2" FOR SIGNAL) (1-2" FOR PEDESTRIAN CABLE) (2-2" FOR SPARE)
- D = 3-2" UNDERGROUND/UNDER PAVEMENT CONDUITS (1-2" FOR SIGNAL) (1-2" FOR PEDESTRIAN CABLE) (1-2" FOR SPARE)
- F = 1-1" UNDERGROUND CONDUIT

| NO. | DATE | REVISIONS | BY | APP. |
|-----|------|-----------|----|------|
| | | | | |

- NOTES
- ANY CONDUIT ABOVE GROUND SHALL BE ALUMINUM OR HD GALVANIZED.
 - ANY CONDUIT BELOW GROUND SHALL BE SCHEDULE 40 PVC.
 - ALL CONDUIT TO BE PLUMBED, CENTERED AND NO LOWER/HIGHER THAN THE MIDPOINT IN THE PULL BOX.
 - IF VIDEO AND LOOPS ARE USED SIMULTANEOUSLY AT AN INTERSECTION THEY SHOULD BE INSTALLED PER FDOT STANDARDS.
 - ALL PULL BOXES FOR POWER SERVICE SHALL BE 13x24x12 OR 17x30x12 OR AS DETERMINED BY ENGINEER.
 - ALL PULL BOXES FOR SIGNAL, PDS, OR LOOPS SHALL BE 13x24x12 OR 17x30x12 OR AS DETERMINED BY ENGINEER.
 - ALL SIGNAL CABLE MUST BE HELD BY A STRAIN RELIEF (LEGRAND FC0750FSS) ATTACHED TO A J HOOK INSIDE OF MAST ARM. TO USE APPROVED EQUIVALENT, SHOP DRAWINGS SHALL BE SUBMITTED TO PBC ENGINEER FOR PRE APPROVAL. WRITTEN APPROVAL FOR SHOP DRAWINGS SHALL BE PROVIDED AT TIME OF FINAL SIGNAL INSPECTION.
 - ANY UNUSED CONDUIT SHALL BE CAPPED WITH AN END CAP.

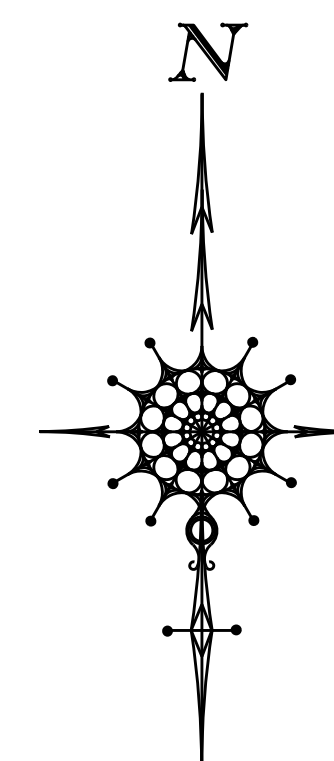

- GENERAL NOTES:
- THIS DRAWING IS NOT TO SCALE.
 - DESIGN, LAYOUT & DATA ON THIS SHEET ARE FOR ILLUSTRATION PURPOSE ONLY.

PALM BEACH COUNTY, FLORIDA
TRAFFIC DIVISION
SIGNAL TYPICAL

CABLE DISTRIBUTION SYSTEM
FOR MAST ARM INSTALLATION

| | | | | | |
|------------|--|----------|--|--------------------|--|
| SIGNATURE | | DATE | | FATMEH N. JAFAR | |
| DRAWN BY | | SCALE | | ENGINEER OF RECORD | |
| CHECKED BY | | N. T. S. | | CONTRACT NO. | |

NOTES:

1. LENGTHS OF CONDUIT ARE DETERMINED BY SUBJECT DESIGN.
2. MINIMUM 3 PULL BOXES NEXT TO CONTROLLER.
3. ILLUMINATED STREET NAME SIGNS (ISNS) AND LUMINAIRE CIRCUITS TO BE RUN SEPARATELY.
4. FOR GROUND ROD INFORMATION SEE NOTES ON T-6.3.

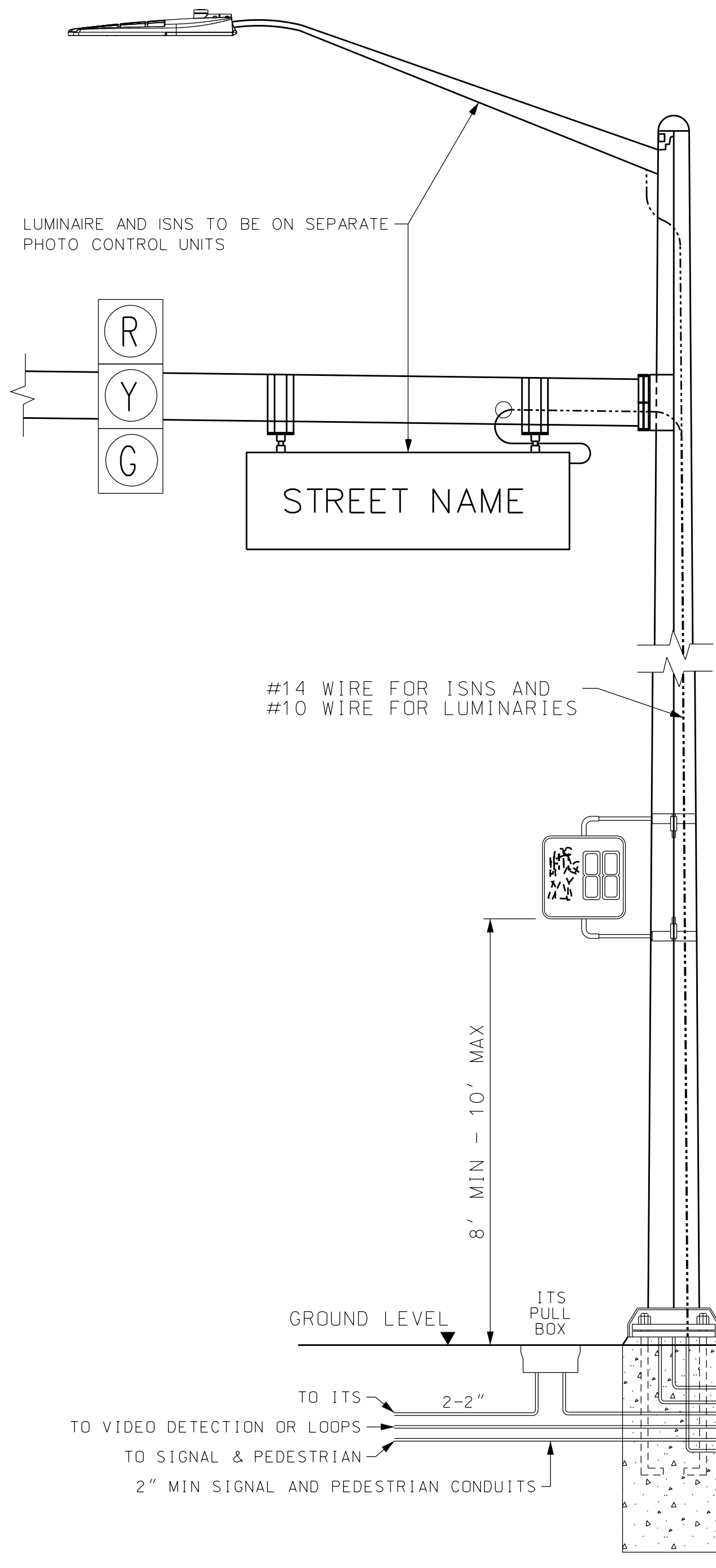

MAST ARM INSTALLATION

NOTE: SPLICE CIRCUIT TO FEED LUMINAIRE AND ISNS WITH WATER PROOF GEL CAP INSIDE POWER SERVICE PULL BOX.

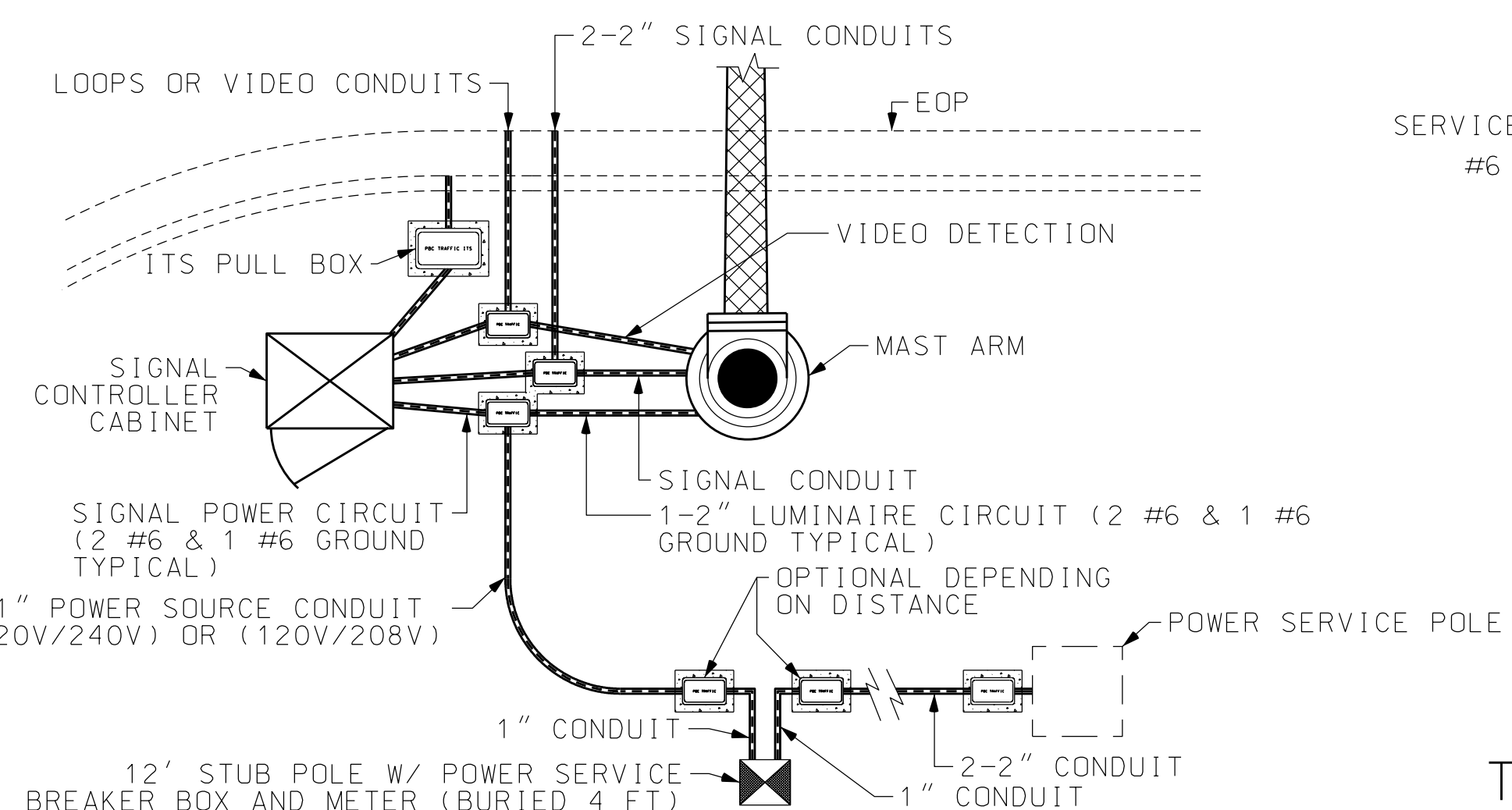

PLAN VIEW

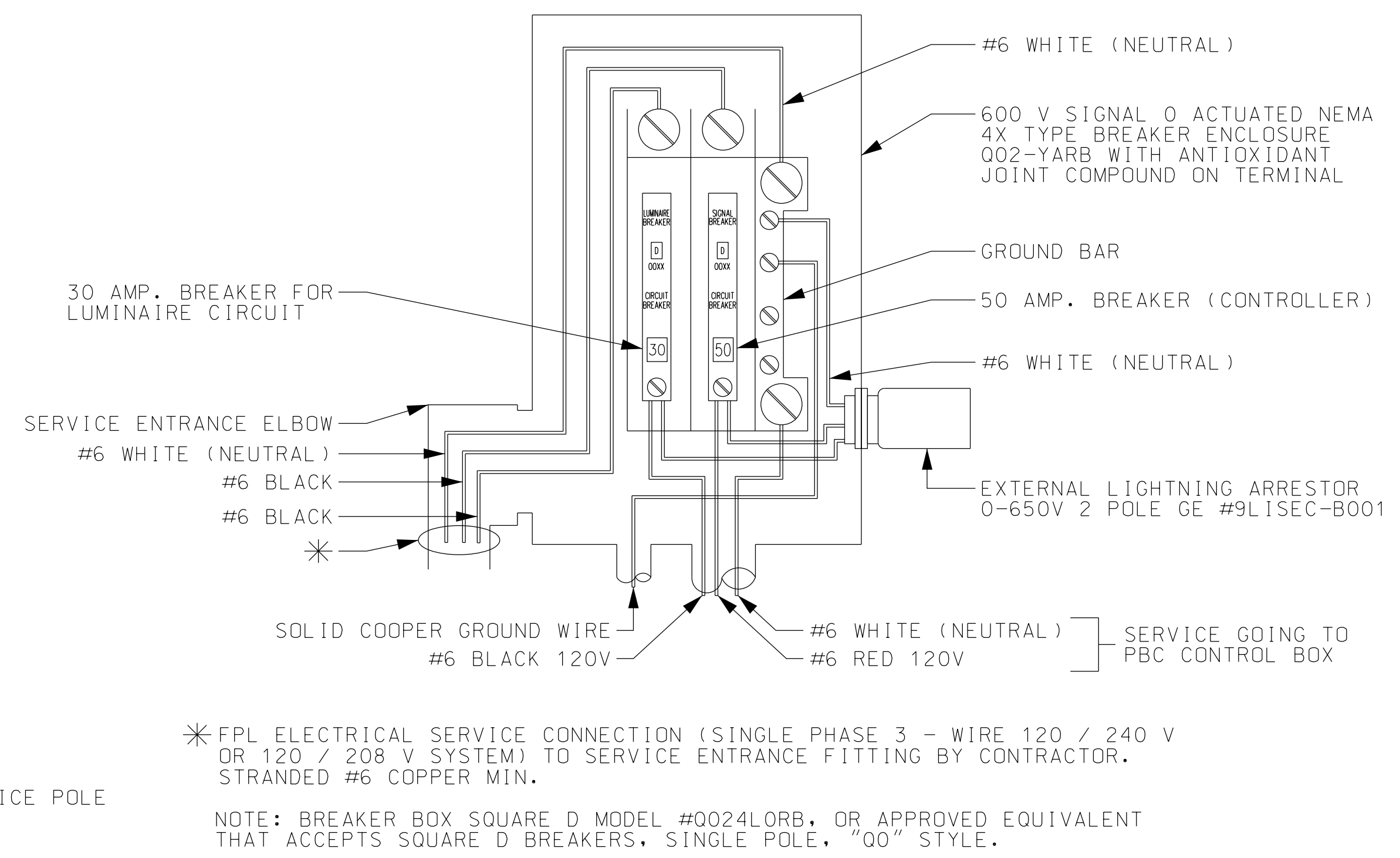

TRIPLEX SERVICE DISCONNECT/BREAKER ASSEMBLY

| | | | |
|--------------|---|----|---|
| GREEN | ● | 1 | ● |
| ORANGE | ● | 2 | ● |
| RED | ● | 3 | ● |
| GREEN-BLACK | ● | 4 | ● |
| ORANGE-BLACK | ● | 5 | ● |
| RED-BLACK | ● | 6 | ● |
| BLUE | ● | 7 | ● |
| WHITE-BLACK | ● | 8 | ● |
| BLACK-WHITE | ● | 9 | ● |
| BLUE-BLACK | ● | 10 | ● |
| BLACK | ● | 11 | ● |
| WHITE | ● | 12 | ● |
| GREEN-WHITE | ● | 13 | ● |
| ORANGE-RED | ● | 14 | ● |
| RED-WHITE | ● | 15 | ● |
| BLUE-WHITE | ● | 16 | ● |
| WHITE-RED | ● | 17 | ● |
| BLACK-RED | ● | 18 | ● |
| BLUE-RED | ● | 19 | ● |
| RED-GREEN | ● | 20 | ● |

- HAND HOLE / TERMINAL BLOCK (TERMINAL COMPARTMENT) NOTES:**
1. TERMINATE ENTIRE HAND HOLE CABLE TO TERMINAL BLOCK.
 2. REMAINING SPARES TO BE TAPED UP AND NOT GROUNDED AT CABINET.
 3. OVERHEAD SIGNAL SPARES & ILLUMINATED STREET NAME SIGNS (ISNS) TO BE GROUNDED AT HAND HOLES WITH GROUND LUGS. (SEE DETAIL)
 4. NO MORE THAN 3 FORKS PER TERMINAL ON TERMINAL STRIP (JUMPERS CAN BE USED AS NEEDED).
 5. ONE TERMINATION PER FORK CONNECTOR. DUAL TERMINATION ONTO A YELLOW FORK IS NOT ACCEPTABLE.

HAND HOLE / TERMINAL BLOCK DETAIL (TERMINAL COMPARTMENT)

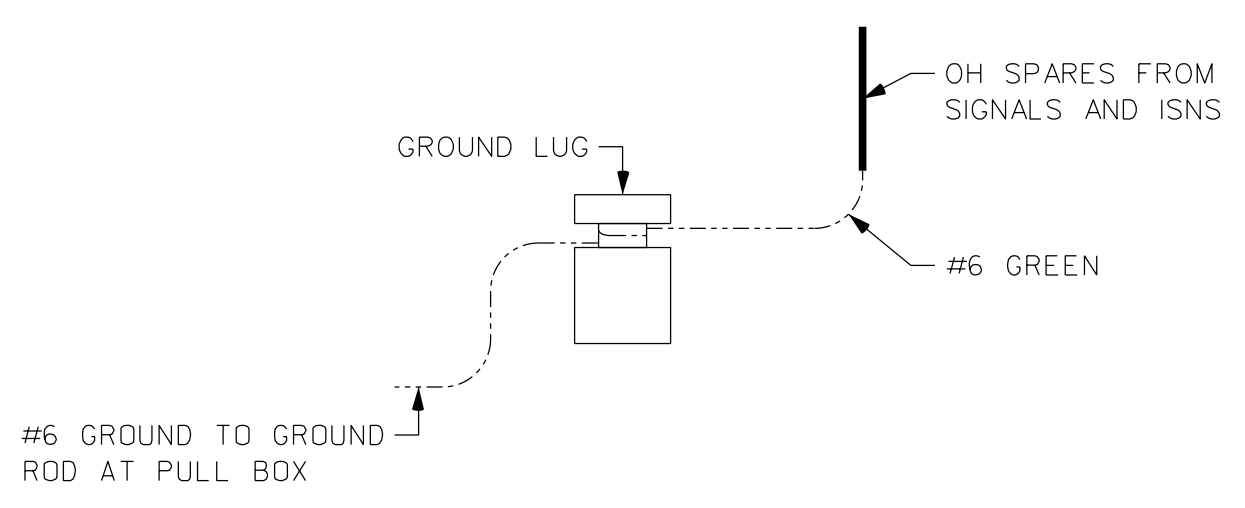

HAND HOLE GROUNDING (SEE NOTE 3)

- GENERAL NOTES:**
1. THIS DRAWING IS NOT TO SCALE.
 2. DESIGN, LAYOUT & DATA ON THIS SHEET ARE FOR ILLUSTRATION PURPOSE ONLY.
 3. STUB POLE TO BE USED ON EXISTING TRAFFIC SIGNALS WITH NO METER INSTALLATION.

PALM BEACH COUNTY, FLORIDA TRAFFIC DIVISION

SIGNAL TYPICAL
SERVICE DISCONNECT/BREAKER ASSEMBLY, MAST ARM HAND HOLE DETAIL, MAST ARM INSTALLATION

SIGNATURE: *Fatme N. Jafar* DATE: _____ FATMEH N. JAFAR ENGINEER OF RECORD

DRAWN BY: _____ DATE: _____ SCALE: _____ CONTRACT NO. _____

CHECKED BY: _____ N. T. S.

| NO. | DATE | REVISIONS | BY | APP. |
|-----|------|-----------|----|------|
| | | | | |

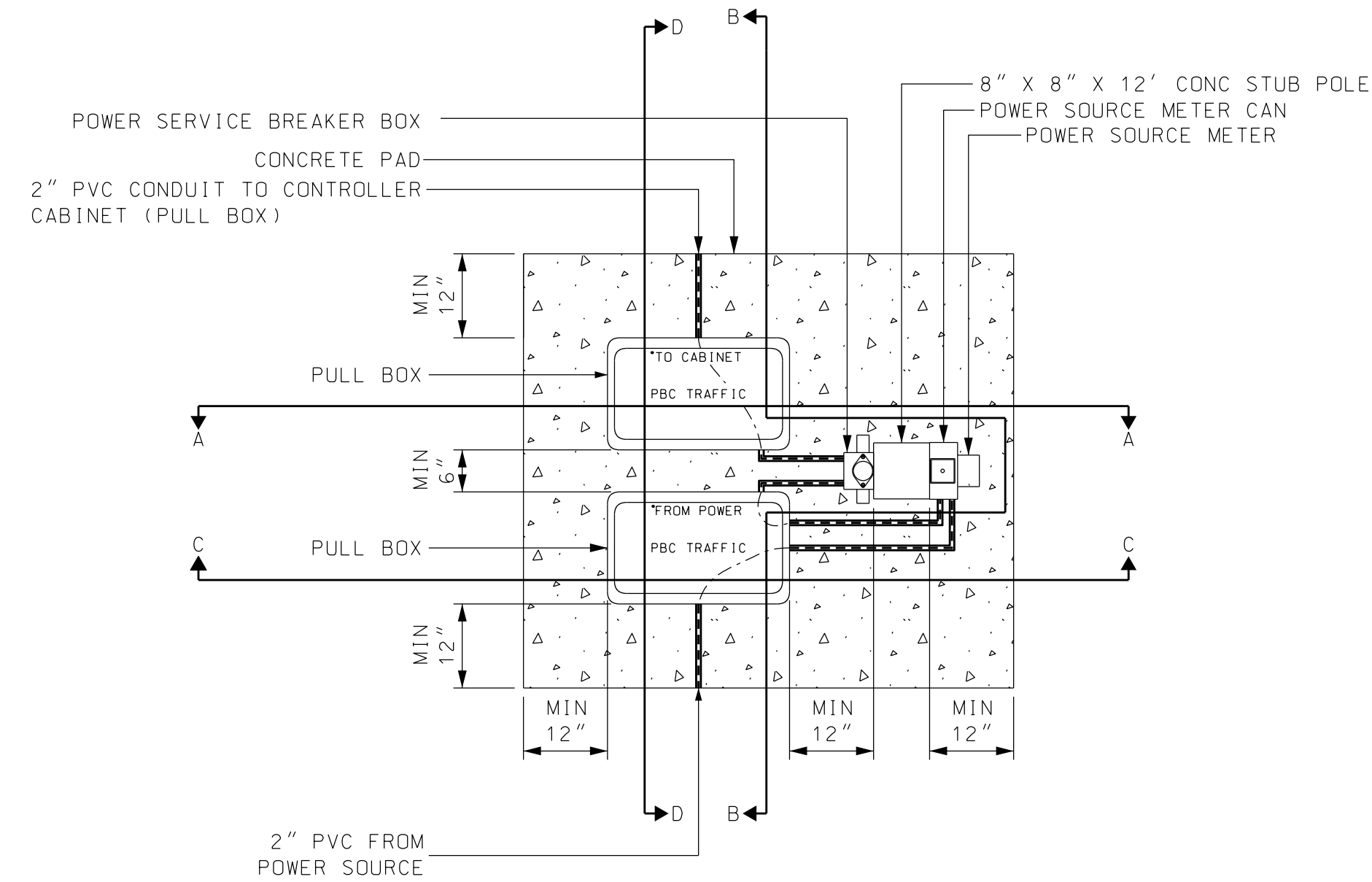

DETAIL NOTES:

- MILBANK METER SOCKET (CATALOG #UAP3505-XL-TG-HSP SERIES U-125 TYPE 3R ENCLOSURE 125 AMP MAX OR PBC APPROVED EQUAL)
- BREAKER BOX SQUARE D MODEL #0024L70RB, OR PBC APPROVED EQUAL.
- CLOSE NIPPLE & GROUNDING BUSHING ON LB. GROUNDING BUSHING ON OFFSET NIPPLES AND METAL CONDUIT ENDS IN PULL BOX.
- RUN #6 BARE SOLID COPPER WIRE FROM BREAKER BOX DOWN THROUGH 1/2" PVC CONDUIT INTO CABINET PULL BOX. THE #6 BARE SOLID COPPER WIRE CONTINUES IN PULL BOX AND CONNECTS TO 5/8" GROUND ROD.
- RUN #6 BARE SOLID COPPER WIRE FROM METER CAN DOWN THROUGH 1/2" PVC CONDUIT INTO POWER SOURCE PULL BOX. THE #6 BARE SOLID COPPER WIRE CONTINUES IN PULL BOX AND CONNECTS TO 5/8" GROUND ROD.
- BOTH 5/8" GROUND RODS ARE BONDED USING #6 GREEN STRANDED COPPER WIRE RUNNING IN 2" PVC UG CONDUIT CONNECTING POWER SOURCE PULL BOX AND CONTROLLER CABINET PULL BOX.
- RUN #6 GREEN STRANDED COPPER FROM GROUND ROD IN CONTROLLER CABINET SIDE PULL BOX TO INTERSECTION.
- EACH PULL BOX SHALL HAVE AT LEAST 20" OF WIRE SLACK FOR EACH RUN.
- WHEN COMPLETED ALL BOLTS SHALL BE INSTALLED IN PULL BOX COVERS.
- FOR BREAKER BOX DETAIL SEE SHEET T-6.2

| | | |
|--|---|---|
| FROM POWER SOURCE BOX TO METER CAN: #6 BLACK STRANDED #6 BLACK STRANDED #6 WHITE STRANDED | FROM METER TO BREAKER BOX: #6 BLACK STRANDED #6 BLACK STRANDED #6 WHITE STRANDED | FROM BREAKER BOX TO LOADS: #6 BLACK STRANDED (LUMINAIRES AND ISNS) #6 RED STRANDED (CABINET) #6 WHITE STRANDED (NEUTRAL) #6 GREEN STRANDED (GROUND) |
|--|---|---|

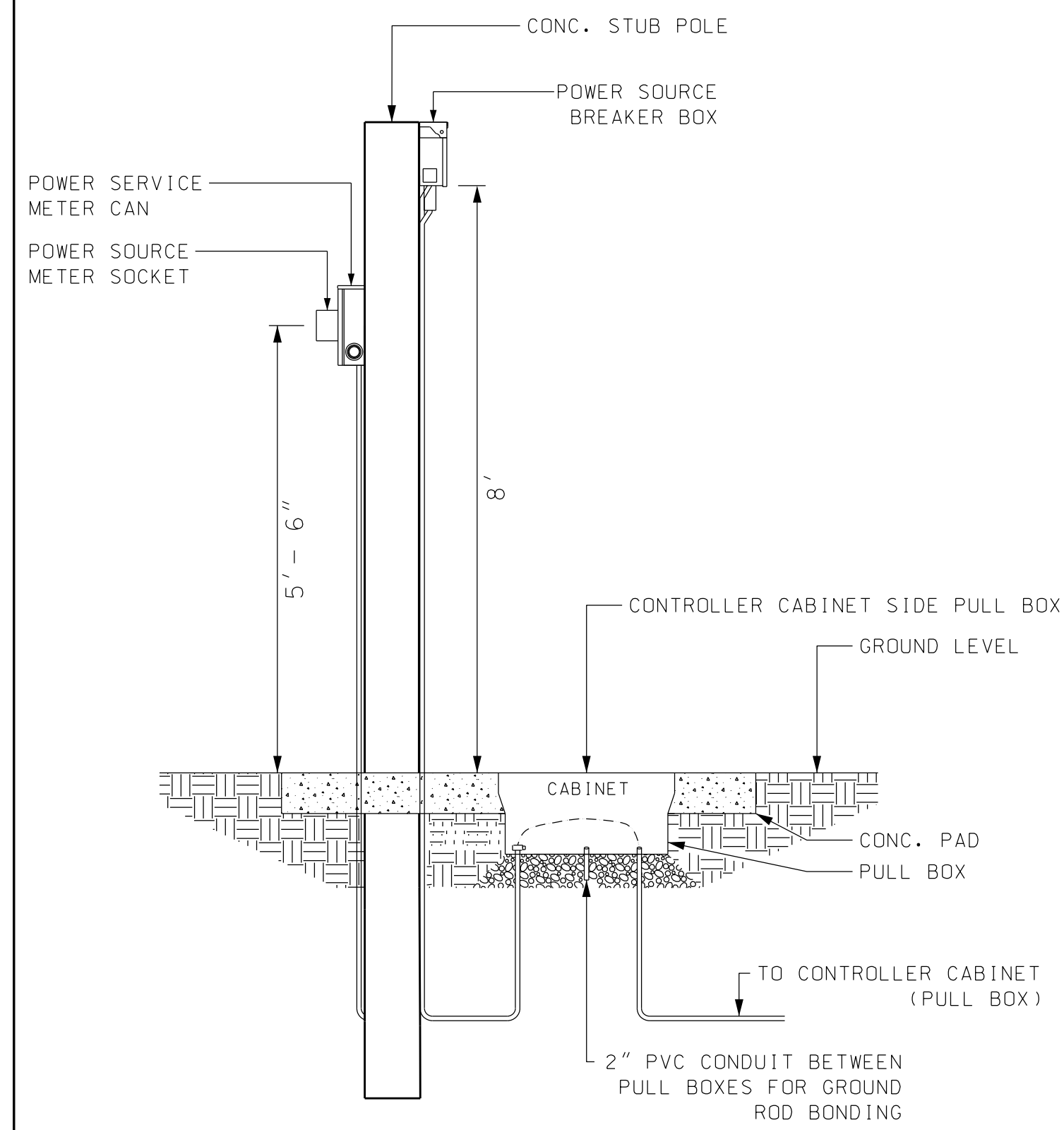

STUB POLE ELEVATION
(CONTROLLER CABINET SIDE DETAILS)
SECTION A-A

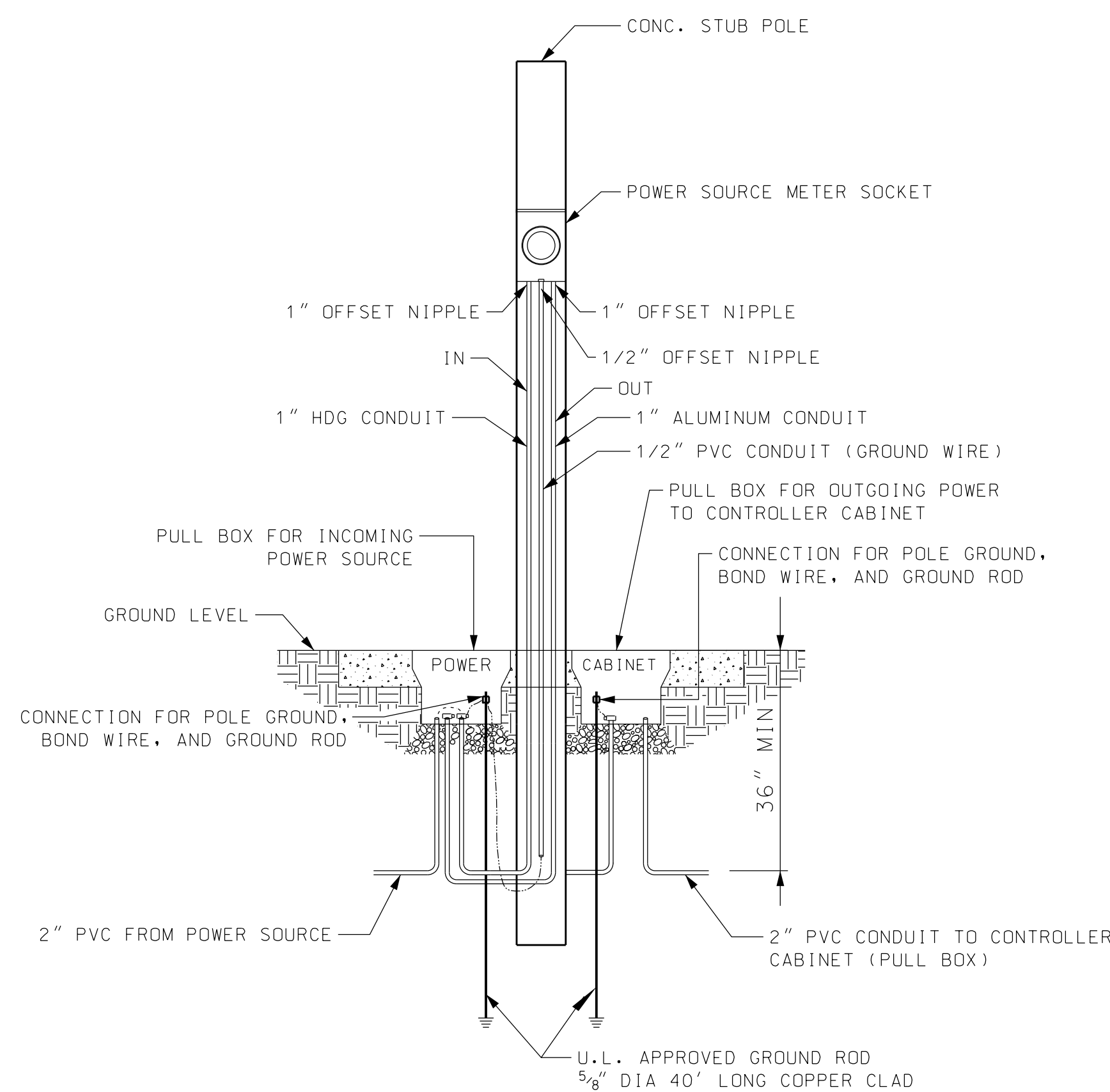

STUB POLE POWER SOURCE METER DETAIL VIEW
SECTION B-B

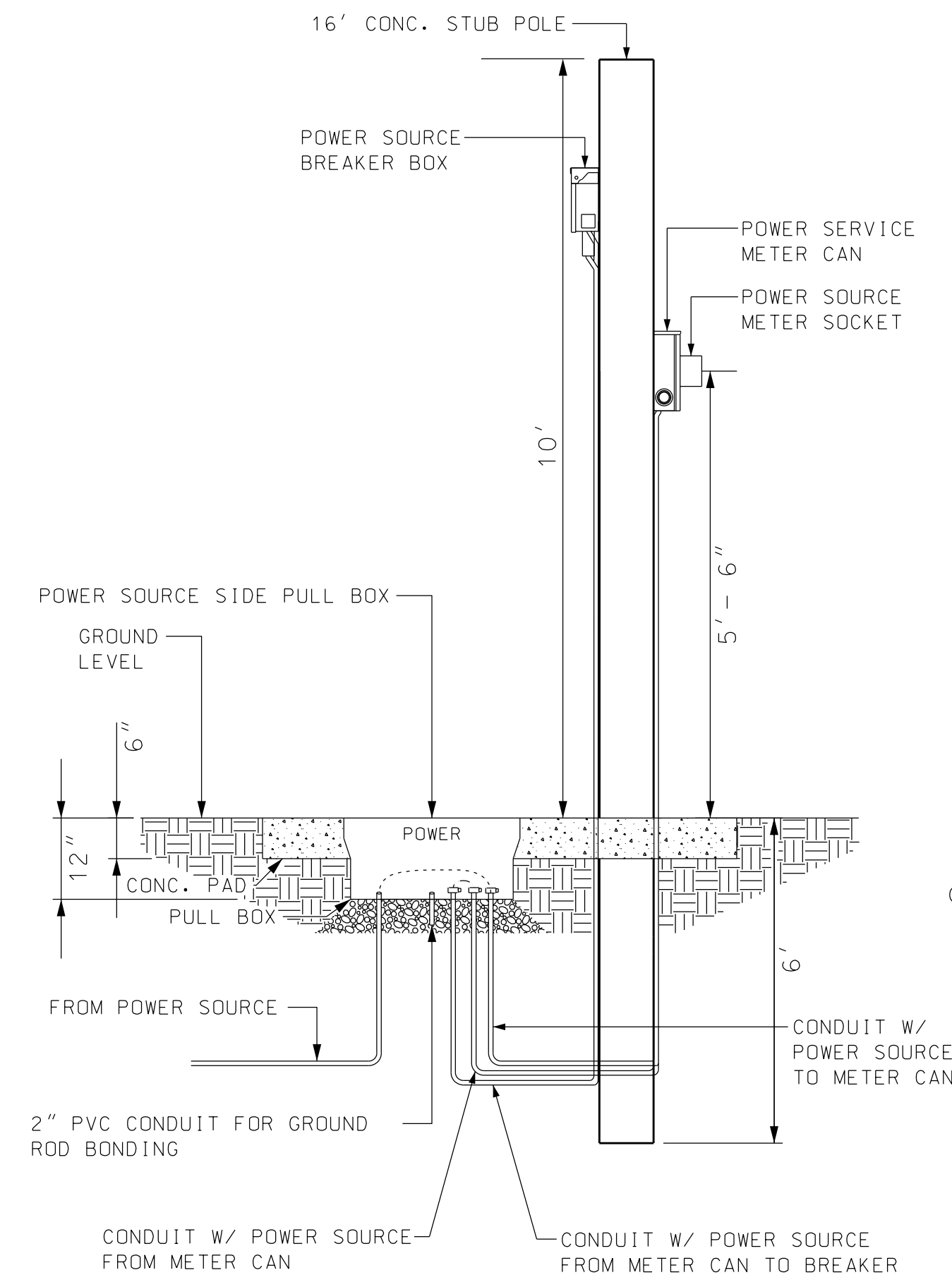

STUB POLE ELEVATION
(POWER SOURCE SIDE DETAILS)
SECTION C-C

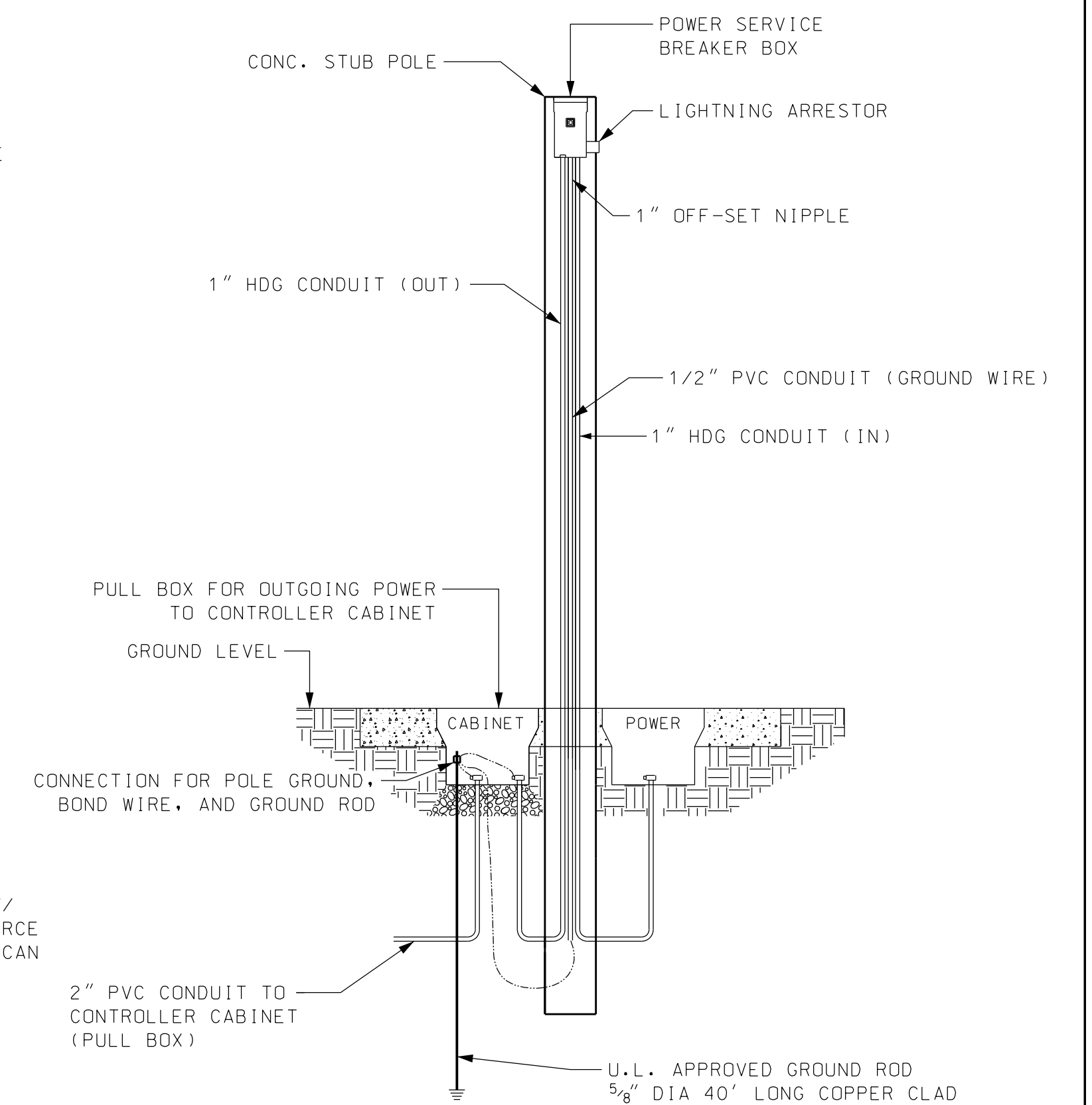

STUB POLE BREAKER BOX DETAIL VIEW
SECTION D-D

GROUND ROD NOTES:

- GROUND RODS MUST BE 5/8" DIA COPPER CLAD STEEL MEETING UL 467 REQUIREMENTS.
- GROUND ROD LENGTH MUST BE A MINIMUM OF 10' AND BE MANUFACTURED FOR THE SOLE PURPOSE OF PROVIDING ELECTRICAL GROUNDING.
- GROUND ROD ASSEMBLIES CONSISTING OF ONE OR MORE GROUND RODS COUPLED TOGETHER SHALL BE A MINIMUM OF 40', EARTHED AT A SINGLE POINT, WITHOUT DISRUPTING THE ELECTRICAL CONTINUITY.
- ALL GROUND ROD CONNECTIONS INSIDE PULL BOXES SHALL BE MADE USING EXOTHERMIC WELDS (ERICO TYPE NX CONNECTIONS OR APPROVED EQUAL).
- ALL GROUND ROD CONNECTIONS INSIDE THE CONTROLLER CABINET OR PEDESTRIAN BASE SHALL BE MECHANICAL CONNECTIONS. BEFORE CONNECTION IS MADE ALL NON CONDUCTING SURFACE COATINGS MUST BE REMOVED AND AN ANTI OXIDANT COMPOUND MUST BE APPLIED.
- FOR THE FOLLOWING DEVICES A RESISTANCE TO GROUND OF NO MORE THAN 5 OHMS MUST BE OBTAINED.

| | |
|---|---------------------------------------|
| MULTIPLE GROUND RODS TOTALING A MAX OF 80' | SINGLE GROUND ROD ASSEMBLIES |
| A. POWER SERVICE FOR TRAFFIC CONTROL DEVICES. | A. PEDESTALS FOR PEDESTRIAN SIGNALS |
| B. SIGNAL AND ITS CABINETS. | B. SIGNAL CABLE / SPAN WIRE |
| C. PULL BOXES | C. AERIAL INTERCONNECT MESSENGER WIRE |

GENERAL NOTES:

- THIS DRAWING IS NOT TO SCALE.
- DESIGN, LAYOUT & DATA ON THIS SHEET ARE FOR ILLUSTRATION PURPOSE ONLY.
- STUB POLE TO BE USED WITH POWER SOURCE METER.

PALM BEACH COUNTY, FLORIDA
TRAFFIC DIVISION
SIGNAL TYPICAL

TYPICAL SPAN SIGNAL
OPERATION AND INSTALLATION

| | | | | | | | |
|-----|---------|---|------|------|---------------|-------|---------------------------------------|
| 1 | 10/5/23 | REVISED STUB POLE LENGTH AND NOTES 1 & 2. | A.K. | M.C. | SIGNATURE | DATE | FATMEH N. JAFAR ENGINEER OF RECORD |
| | | | | | DRAWN BY | SCALE | CONTRACT NO. |
| | | | | | CHECKED BY | | N. T. S. |
| NO. | DATE | REVISIONS | BY | APP. | DRAWING T-6.3 | | SHEET 16 OF 28 |

NOTES:

1. EACH PEDESTRIAN HEAD WILL BE FED WITH ONE SEVEN CONDUCTOR CABLE FOR PEDESTRIAN SIGNAL HEAD AND ONE FOUR CONDUCTOR CABLE FOR PEDESTRIAN DETECTOR. THESE CABLES WILL RUN FROM PEDESTRIAN SIGNAL AND DETECTOR DIRECTLY TO CONTROL BOX (NO SPLICES).
2. HOOK UP FOR PEDESTALS- THERE WILL BE ONE 4 PIN & ONE 8 PIN JIFFY HARNESS SOLDERED TO CABLES IN THE PEDESTAL. THESE HARNESES WILL HAVE THE FEMALE END ON THE FEED SIDE OF CABLE AND THE MALE END ON THE PEDESTRIAN SIDE. THE LOCKING TABS MUST BE CUT OFF TO ENSURE BREAK-A-WAY PROTECTION. THE JIFFY CONNECTOR TO BE POSITIONED IN PELCO BASE AT TOP OF BASE TO AVOID WATER INTRUSION. ADD SILICON OR CAULKING AT BASE OF PELCO FOR WATER INTRUSION PROTECTION.
3. IN FLASHER-CONVERTIBLE INSTALLATIONS, A PULL BOX IS TO BE INSTALLED AT THE LOCATION OF THE FUTURE PEDESTRIAN SIGNAL PEDESTAL BASE. THE PULL BOX IS TO CONTAIN ADEQUATE WIRING FOR HOOK-UP OF FUTURE PEDESTRIAN SIGNAL.
4. BOND PED FIXTURE TO GROUND ROD.
5. ALL PUSH BUTTONS SHALL BE NO MORE THAN 10" FROM BACK OF SIDEWALK
6. FOR GROUND ROD INFORMATION SEE NOTED ON T-6.3.
7. PED PUSH BUTTON SHALL BE BULLDOG TYPE BDL3-B-CE

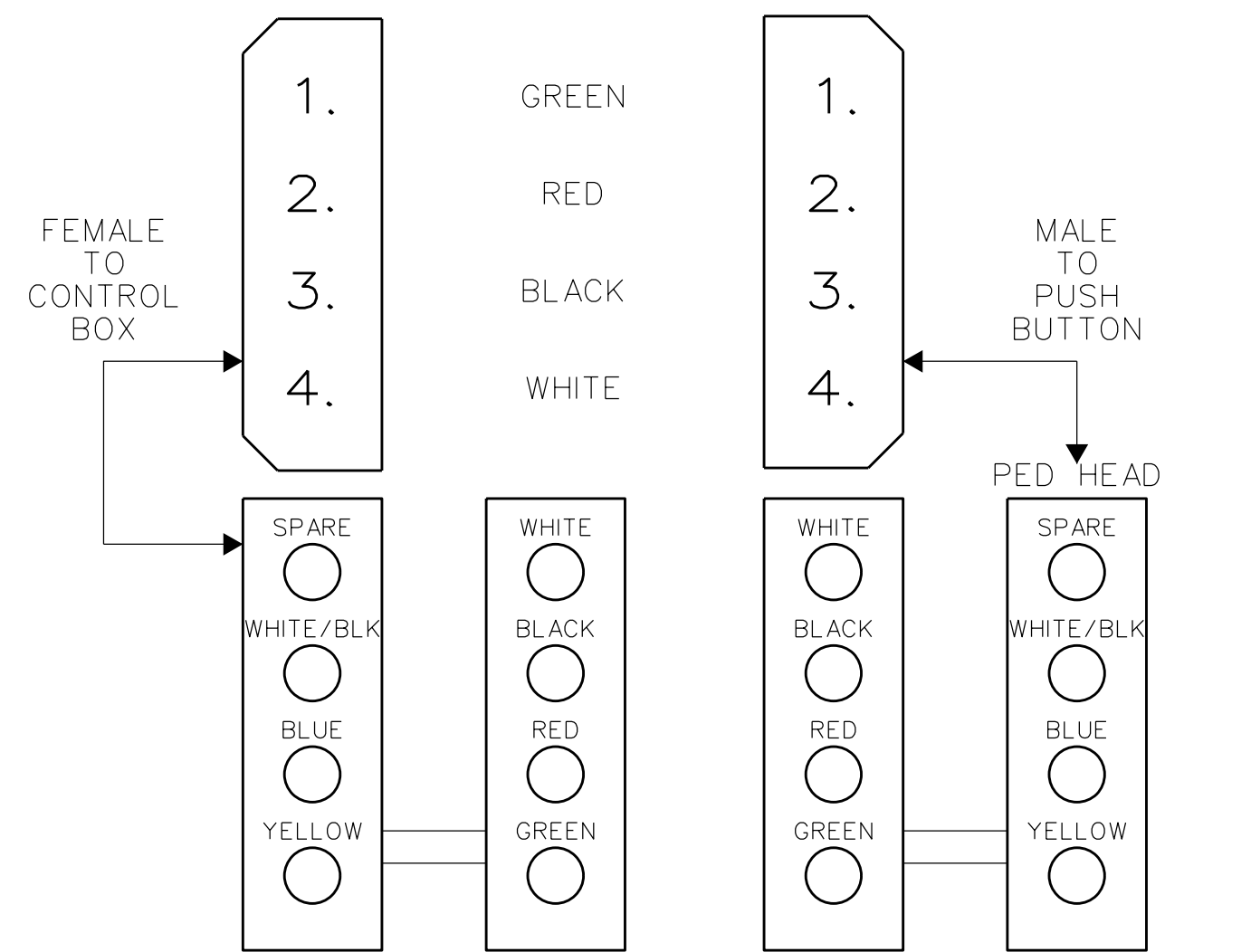

JIFFY HARNESS WIRING DIAGRAM (4 PIN AND 8 PIN)

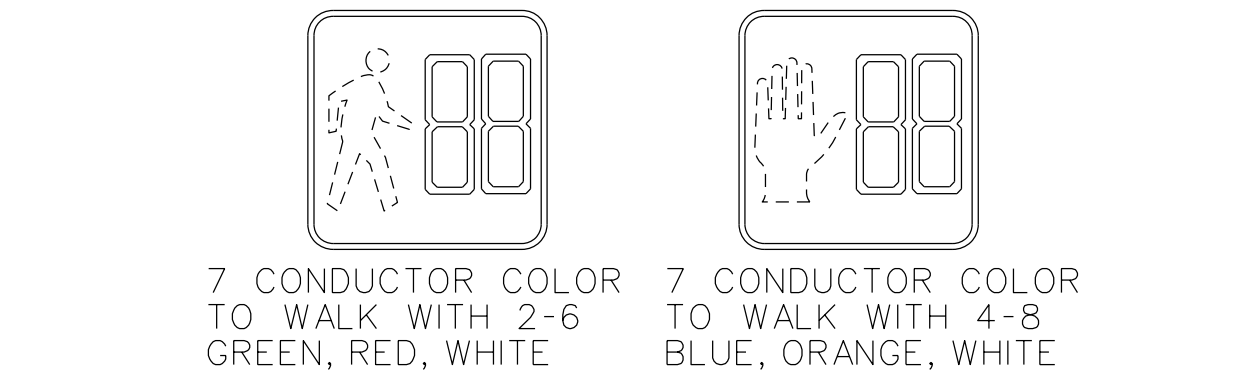
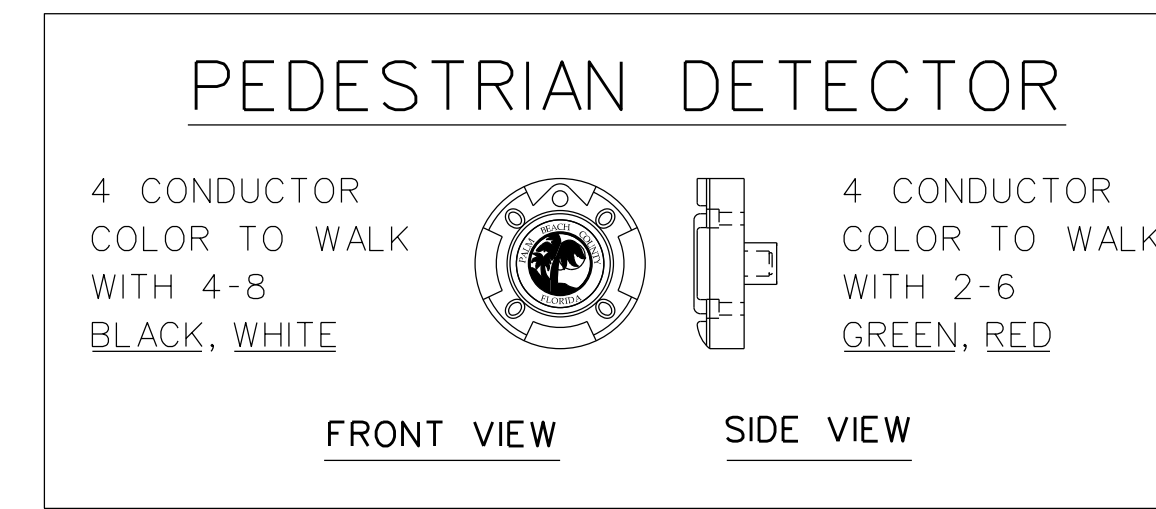

COUNTDOWN PEDESTRIAN SIGNAL

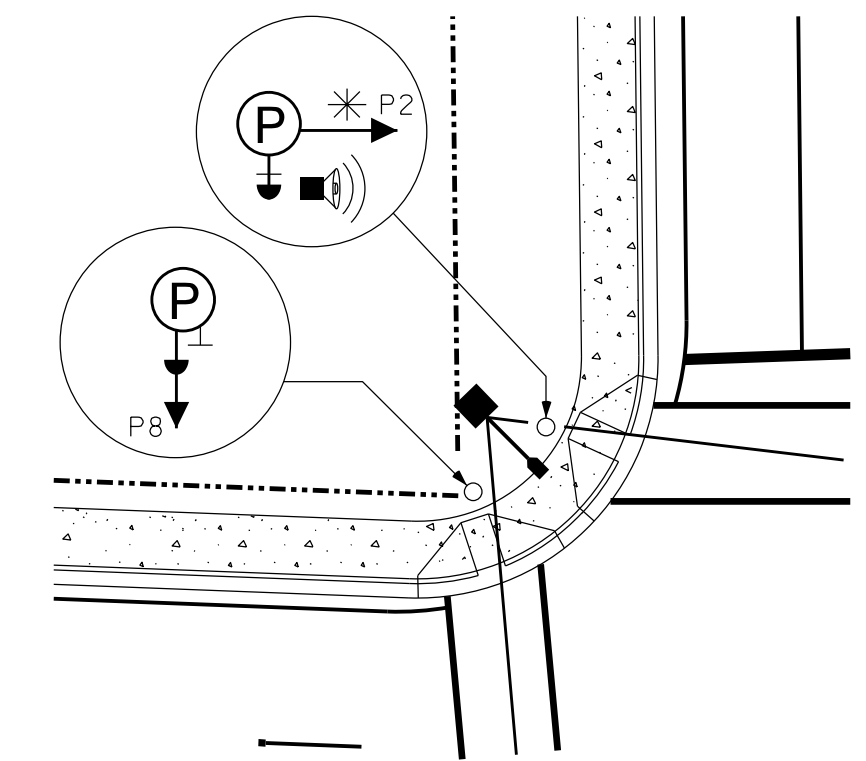
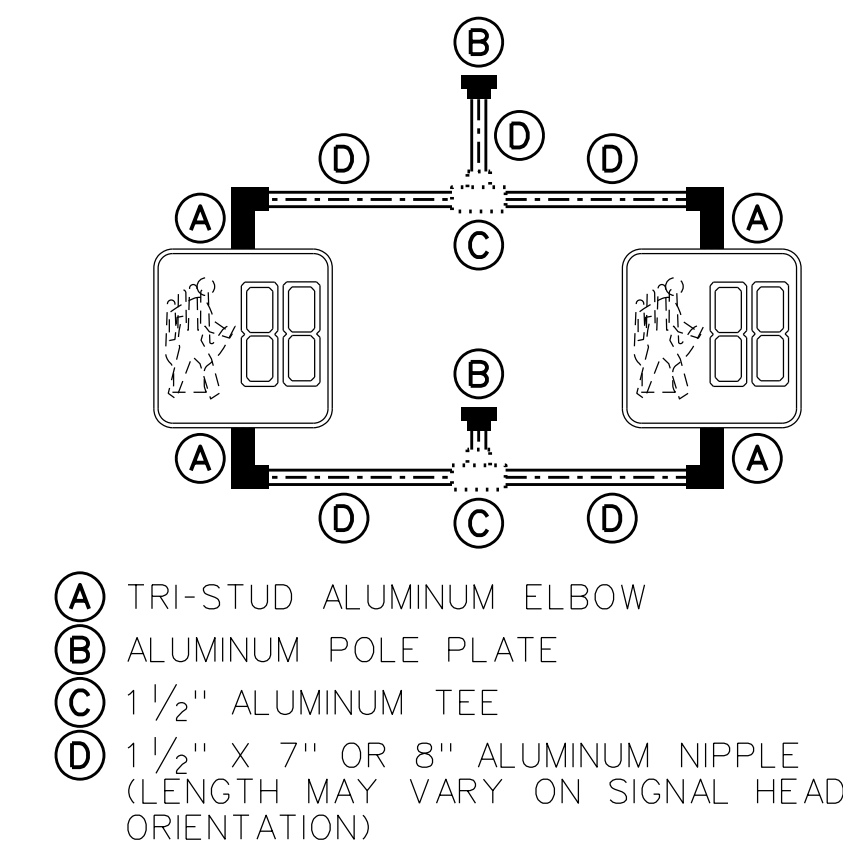

* P2 AUDIBLE DETECTOR

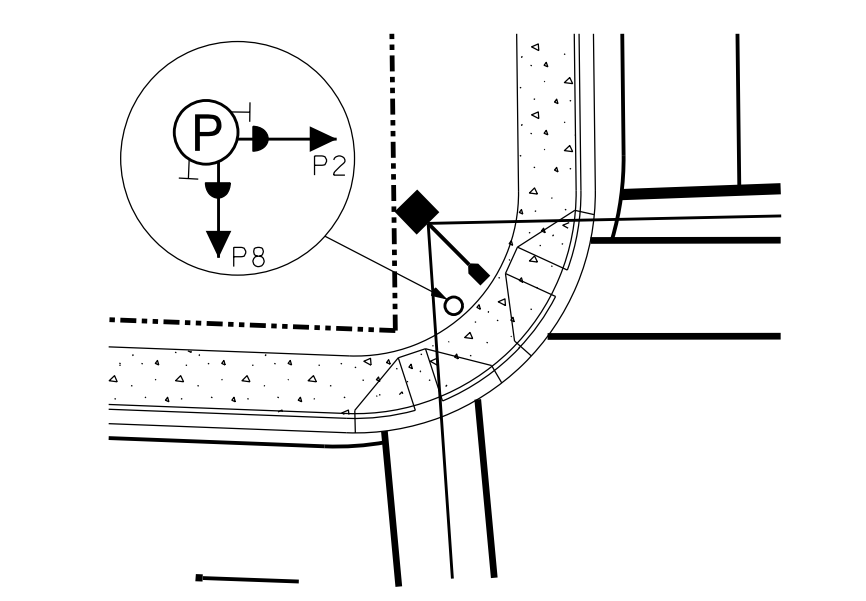

PEDESTRIAN FEATURES LAYOUT DETAIL

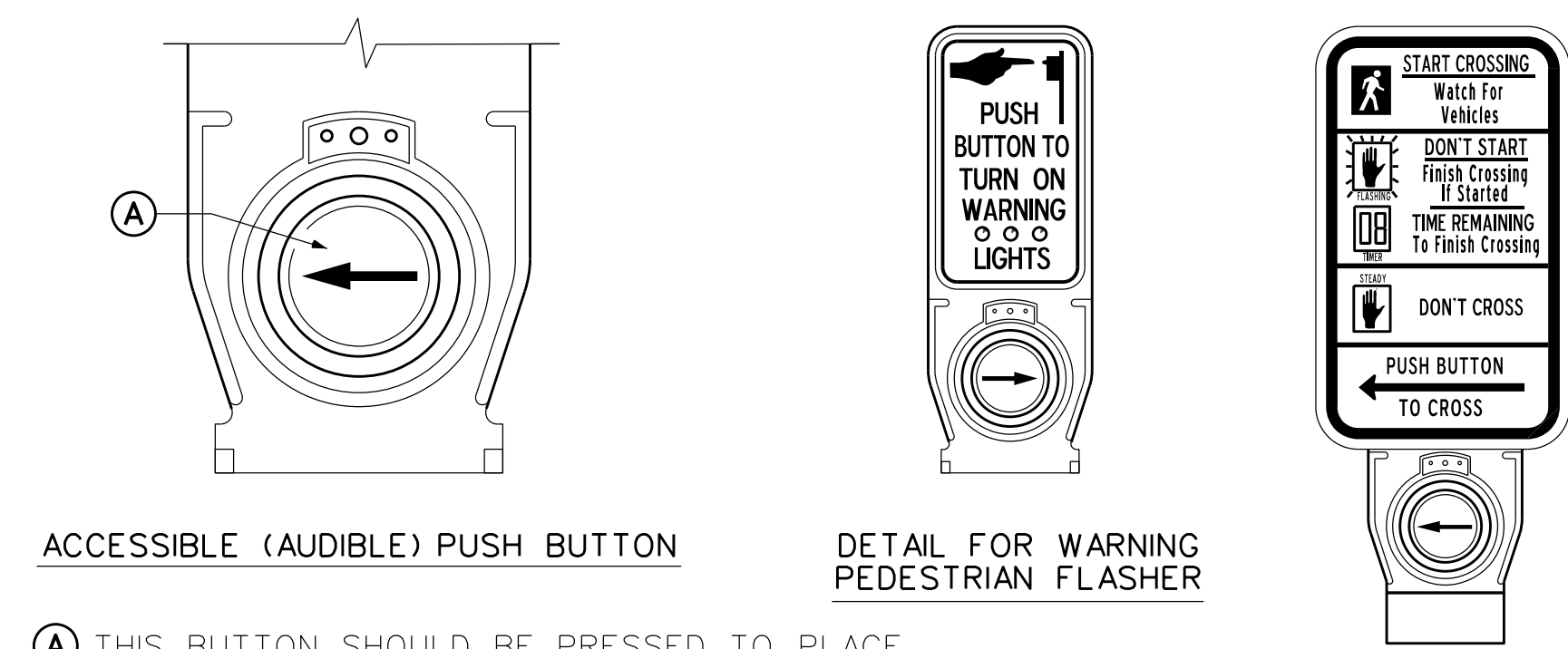

ACCESSIBLE (AUDIBLE) PUSH BUTTON

DETAIL FOR WARNING PEDESTRIAN FLASHER

(A) THIS BUTTON SHOULD BE PRESSED TO PLACE A PED CALL. THE RAISED ARROW INDICATES THE DIRECTION THROUGH THE CROSSWALK. THE BUTTON VIBRATES TO INDICATE THE WALK SIGN IS ON.

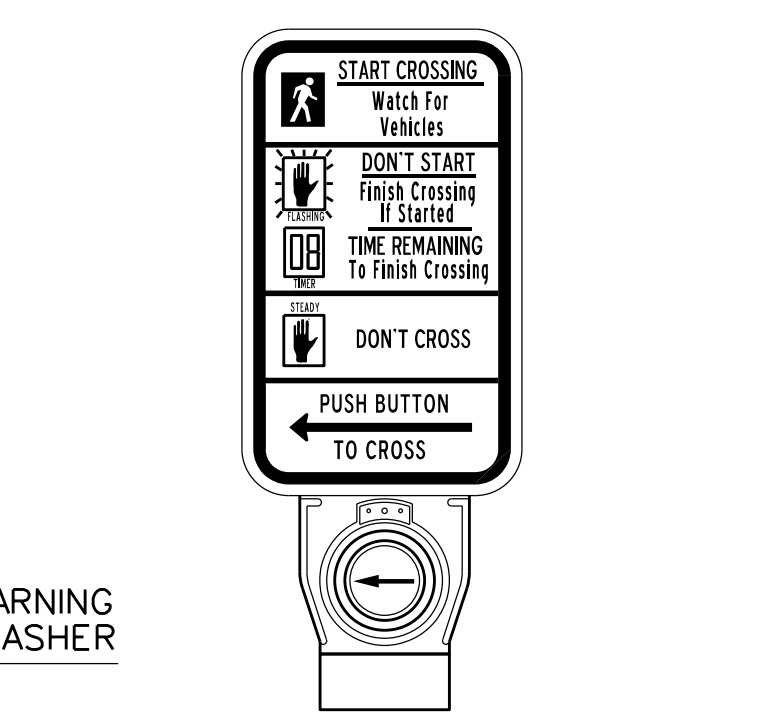

DETAIL FOR ACCESSIBLE PEDESTRIAN DETECTOR IN COMBINATION WITH COUNTDOWN PEDESTRIAN SIGNAL SIGN

ACCESSIBLE (AUDIBLE) PEDESTRIAN DETECTOR DETAIL

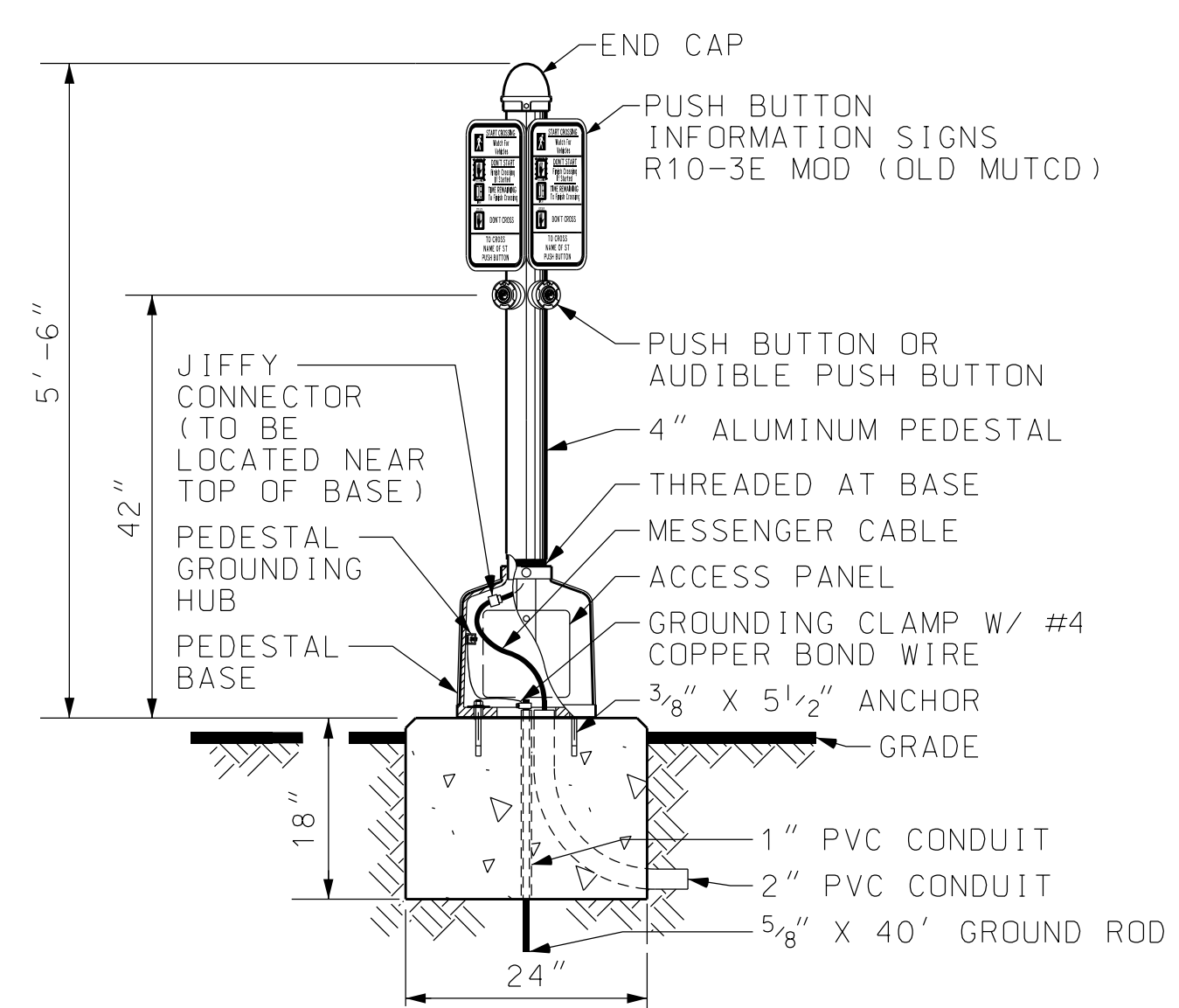

PED MONUMENT DETAIL

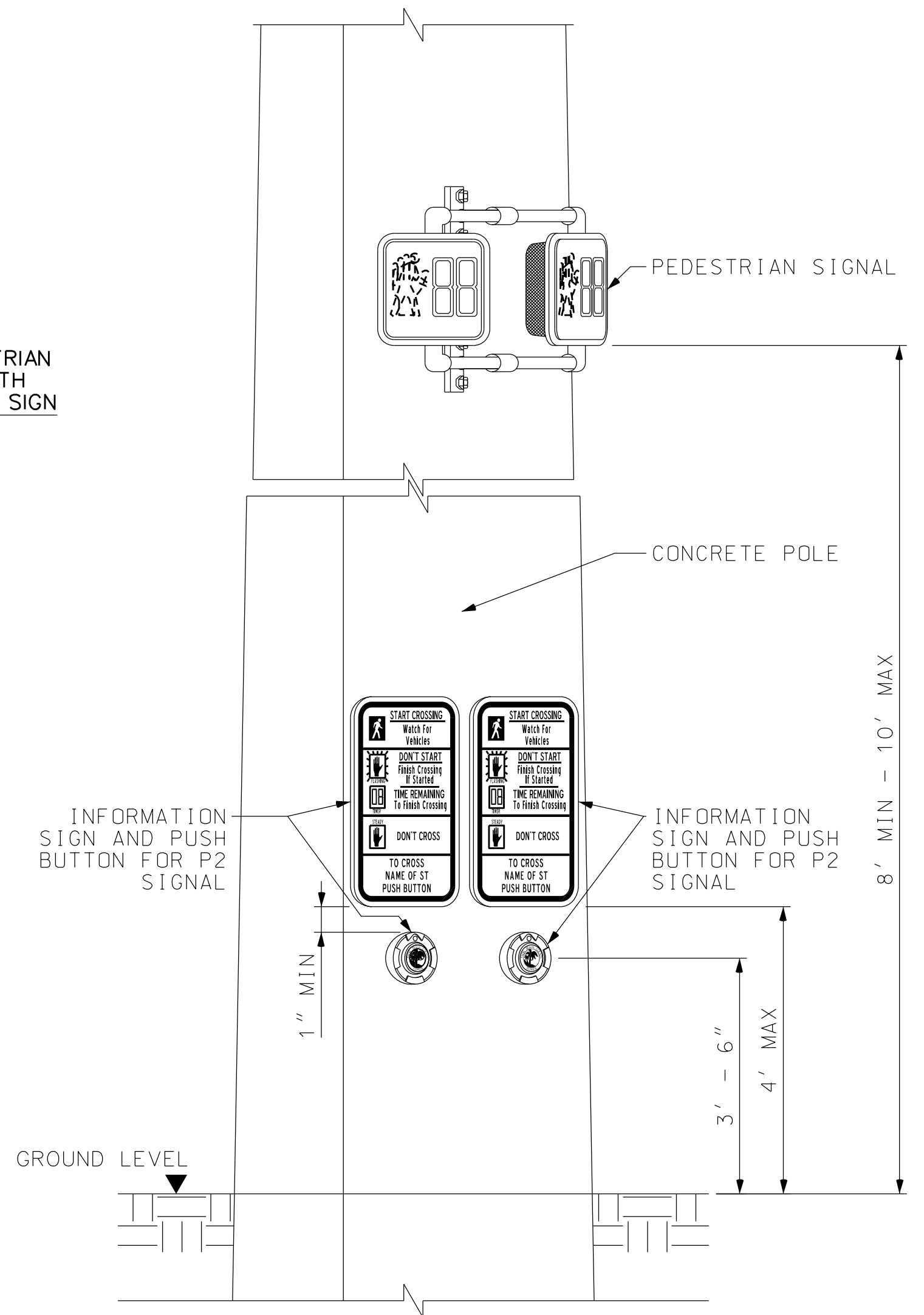

PEDESTRIAN FEATURES ON CONCRETE POLE

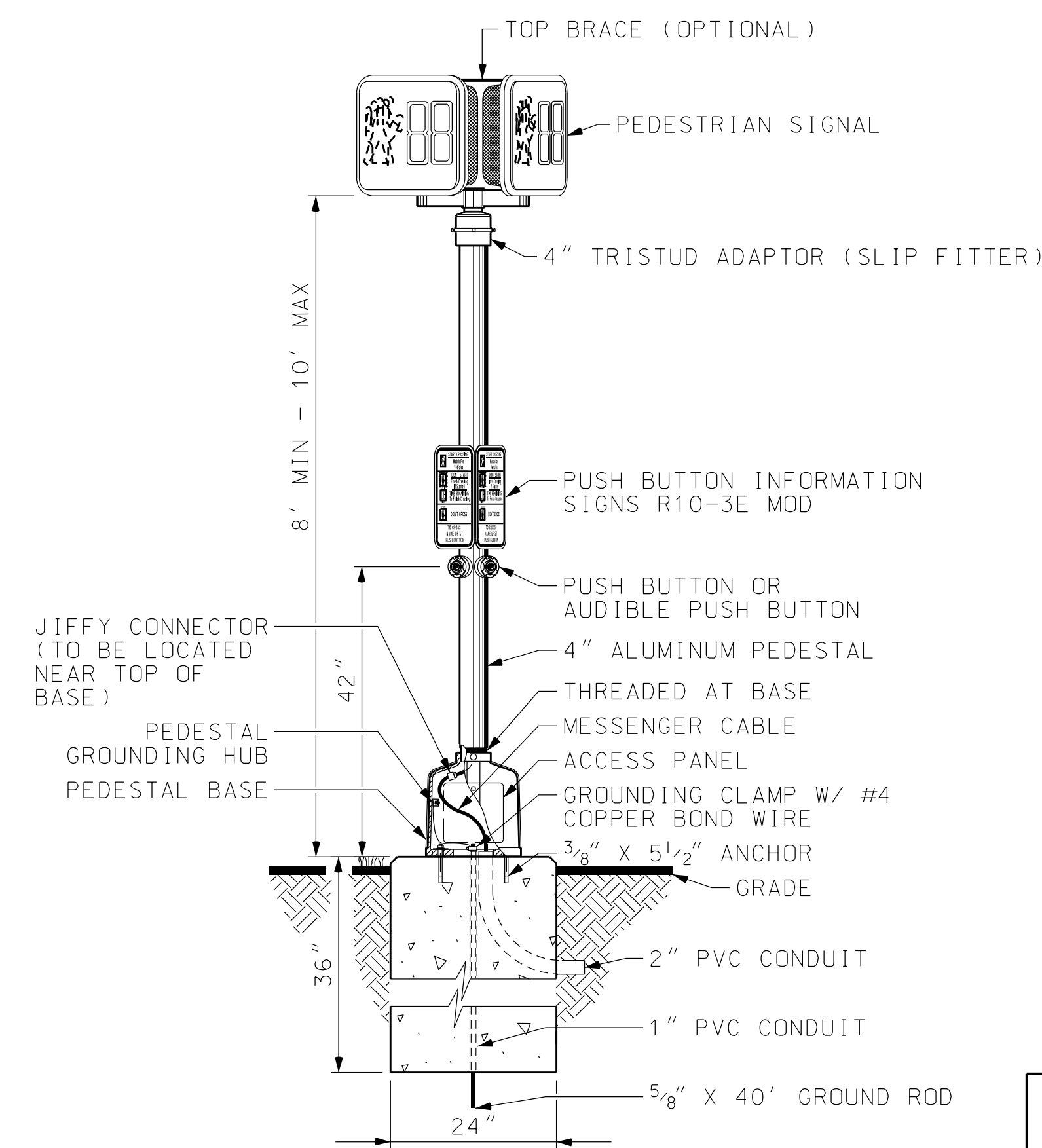

PEDESTRIAN FEATURES ON PEDESTAL

GENERAL NOTES:
 1. THIS DRAWING IS NOT TO SCALE.
 2. DESIGN, LAYOUT & DATA ON THIS SHEET ARE FOR ILLUSTRATION PURPOSE ONLY.

PALM BEACH COUNTY, FLORIDA TRAFFIC DIVISION SIGNAL TYPICAL

PEDESTRIAN SIGNAL, SIGN, & EQUIPMENT INSTALLATION.

SIGNATURE: *Fatme N. Jafar* DATE: FATMEH N. JAFAR ENGINEER OF RECORD
 DRAWN BY: NAME DATE SCALE CONTRACT NO.
 CHECKED BY: N. T. S.

| NO. | DATE | REVISIONS | BY | APP. |
|-----|------|-----------|----|------|
| | | | | |

NOTES:

1. FOR GROUND ROD INFORMATION SEE NOTES ON T-6.3.
2. PEDESTAL BASE DOORS MUST BE INSTALLED FACING TRAFFIC.
3. PEDESTALS MUST BE SECURED TO BASE WITH SET SCREW TO PREVENT MOVEMENT.

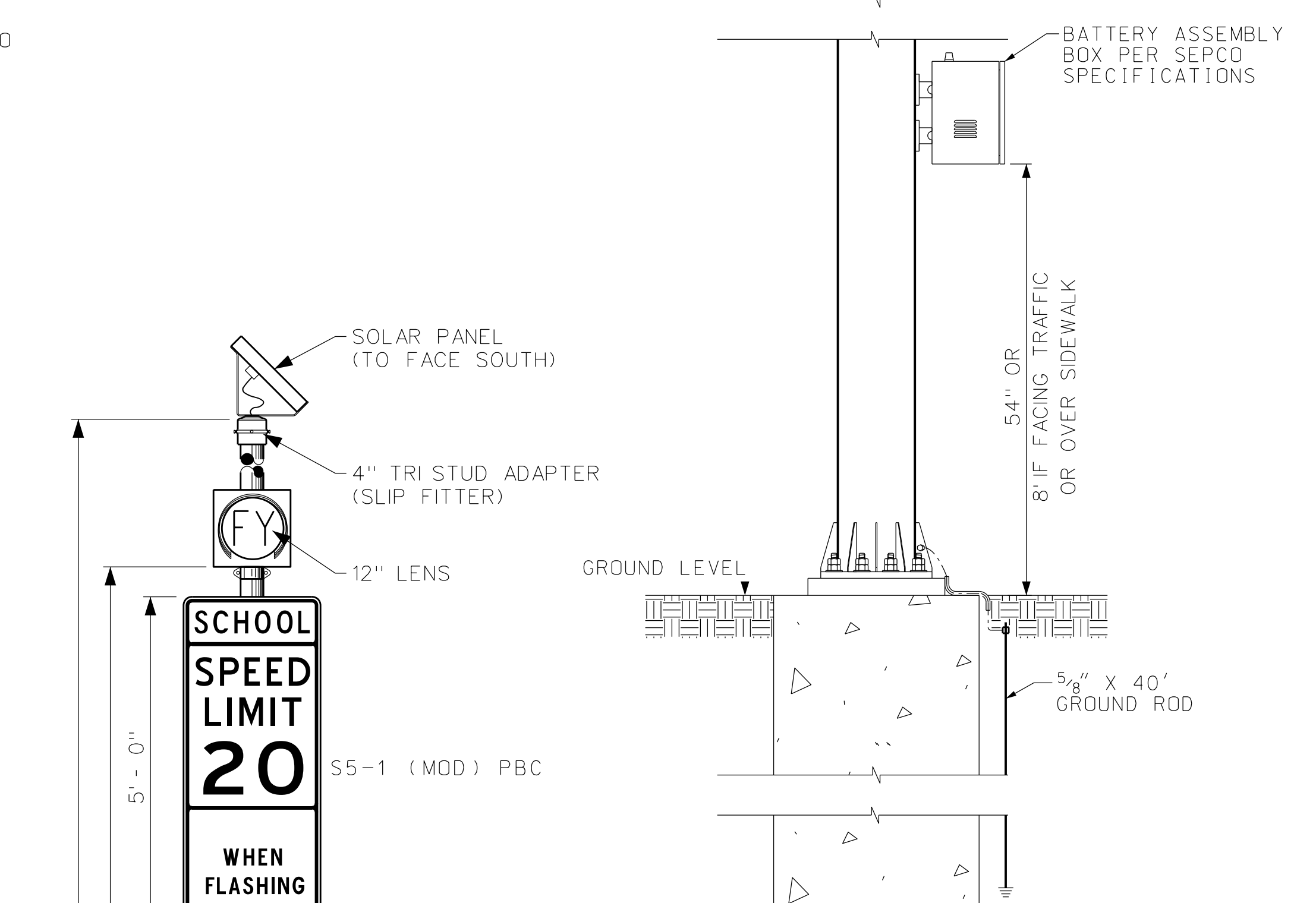
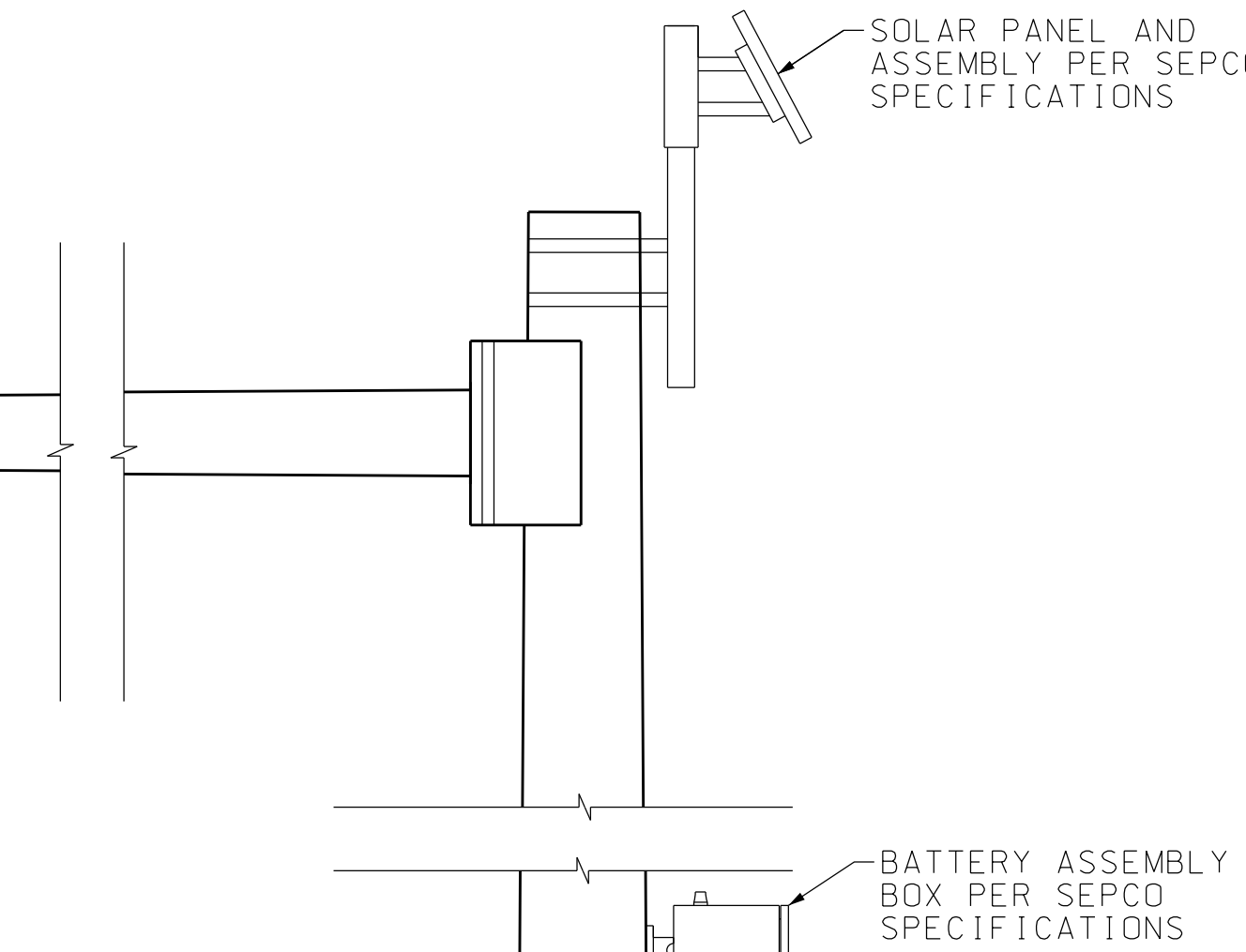
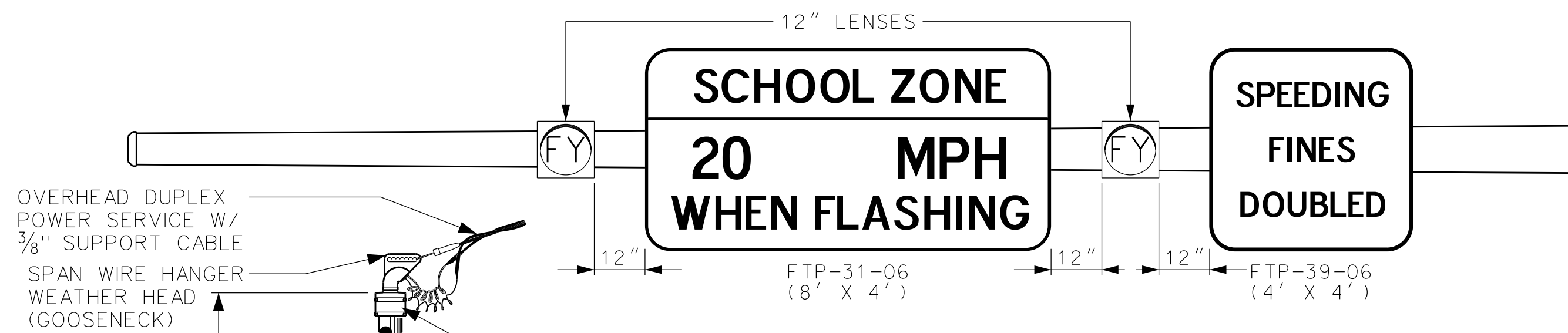
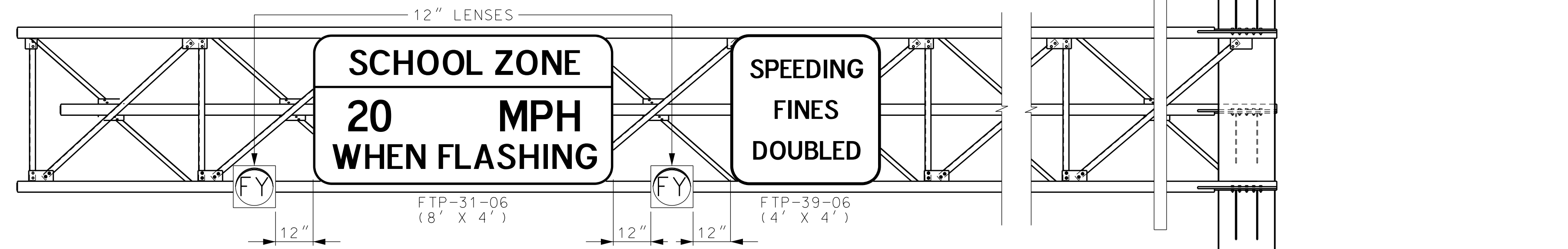

OVERHEAD SCHOOL ZONE FLASHER (CANTILEVER)

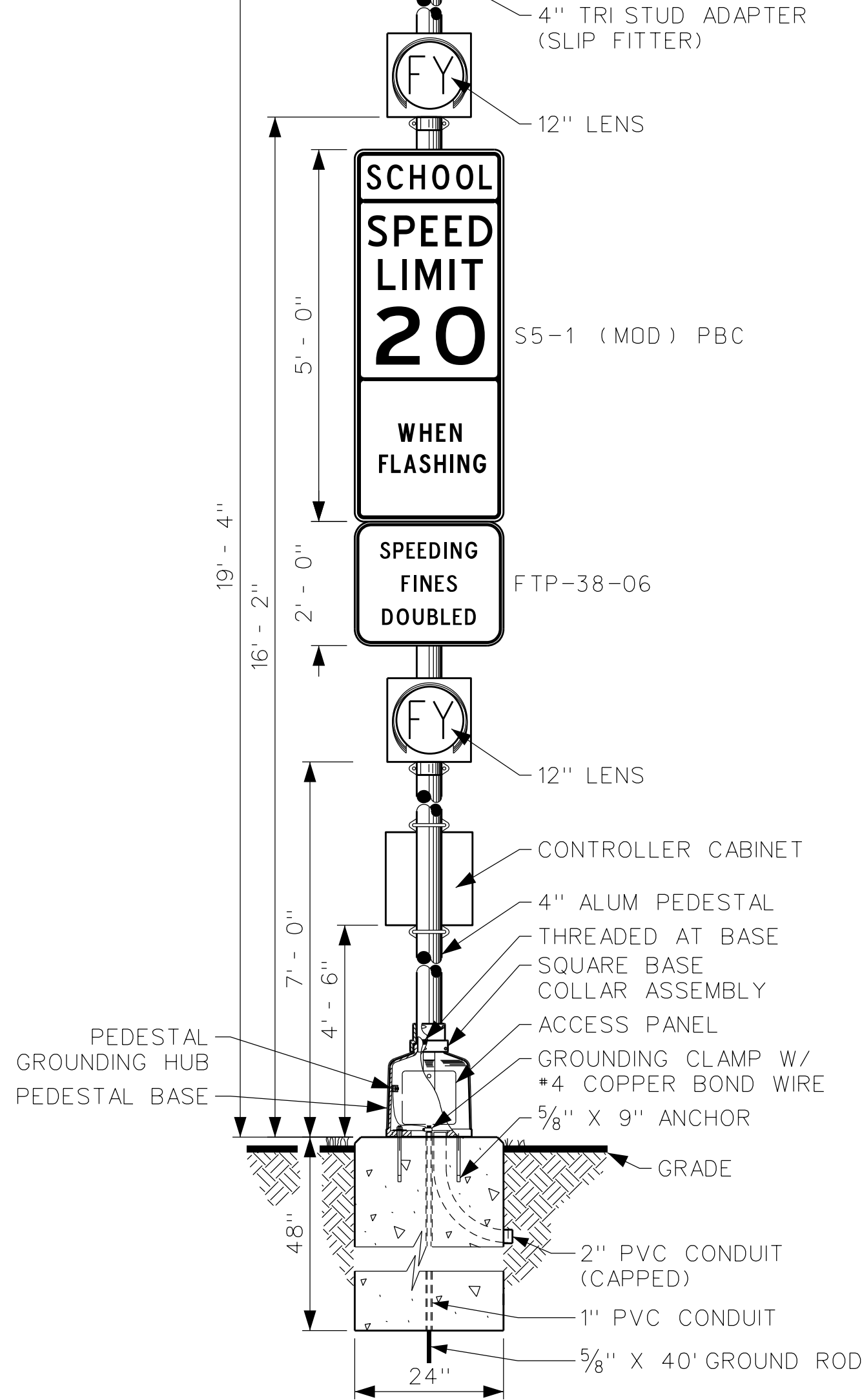

PEDESTAL SCHOOL ZONE FLASHER OVERHEAD POWERED DETAIL

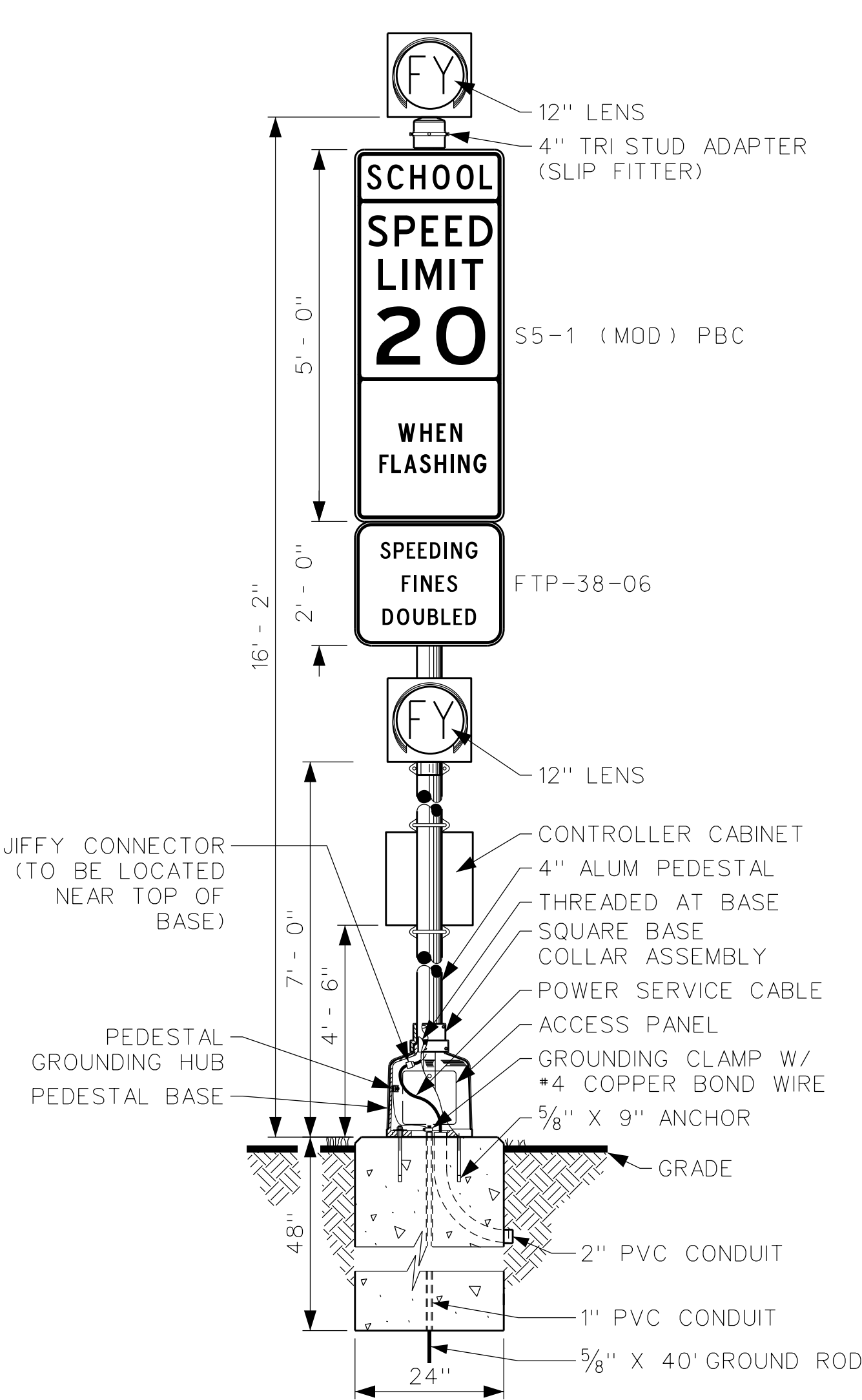

PEDESTAL SCHOOL ZONE FLASHER UNDERGROUND POWERED DETAIL

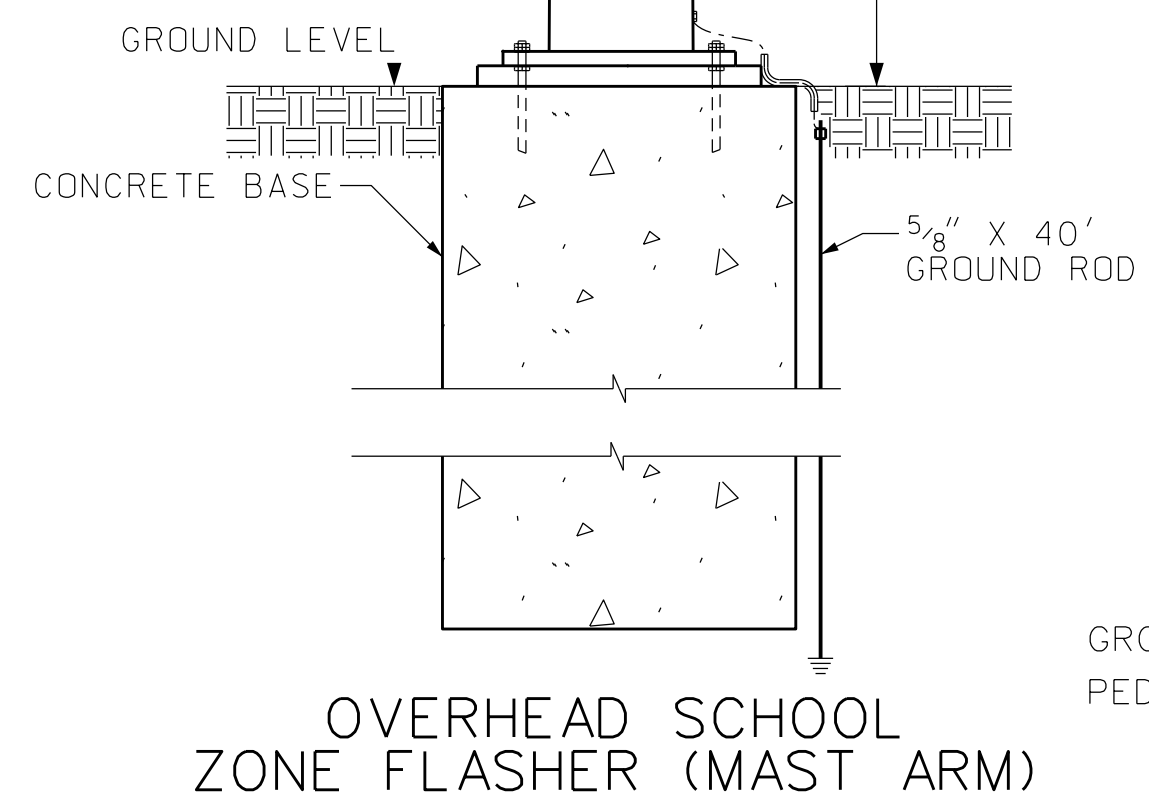

OVERHEAD SCHOOL ZONE FLASHER (MAST ARM)

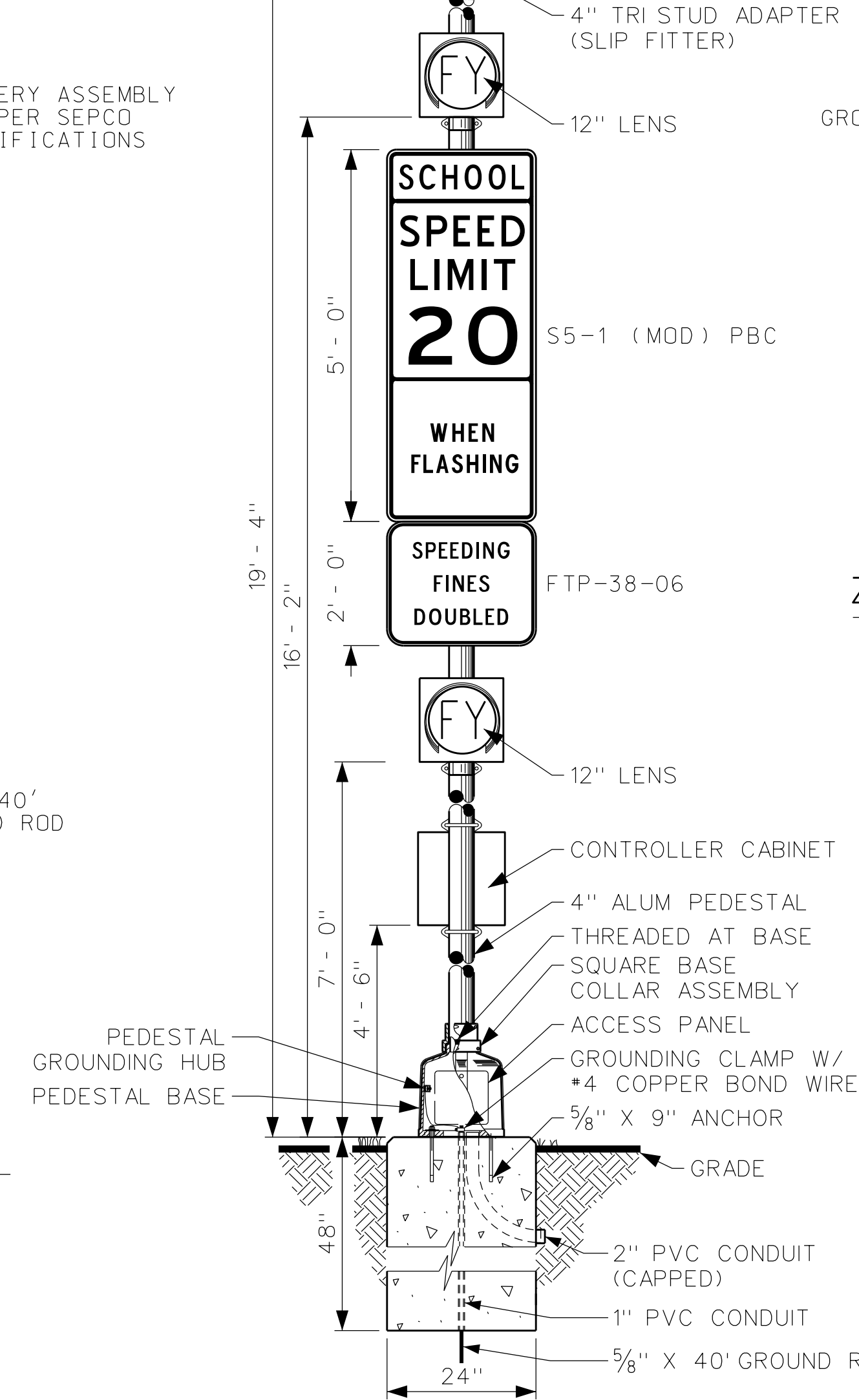

PEDESTAL SCHOOL ZONE FLASHER SOLAR POWERED DETAIL

| NO. | DATE | REVISIONS | BY | APP. |
|--|------|--------------------|----|------|
| GENERAL NOTES: 1. THIS DRAWING IS NOT TO SCALE. 2. DESIGN, LAYOUT & DATA ON THIS SHEET ARE FOR ILLUSTRATION PURPOSE ONLY. | | | | |
| PALM BEACH COUNTY, FLORIDA TRAFFIC DIVISION SIGNAL TYPICAL | | | | |
| SCHOOL ZONE FLASHER DETAIL | | | | |
| SIGNATURE | | FATMEH N. JAFAR | | |
| DRAWN BY | | ENGINEER OF RECORD | | |
| CHECKED BY | | SCALE | | |
| | | CONTRACT NO. | | |
| | | N. T. S. | | |
| DRAWING T-8 | | SHEET 18 OF 28 | | |

NOTES:

1. FOR GROUND ROD INFORMATION SEE NOTES ON T-6.3.
2. PEDESTAL BASE DOORS MUST BE INSTALLED FACING TRAFFIC.
3. PEDESTALS MUST BE SECURED TO BASE WITH SET SCREW TO PREVENT MOVEMENT.
4. ALL PUSH BUTTONS SHALL BE NO MORE THAN 10" FROM THE BACK OF SIDEWALK.

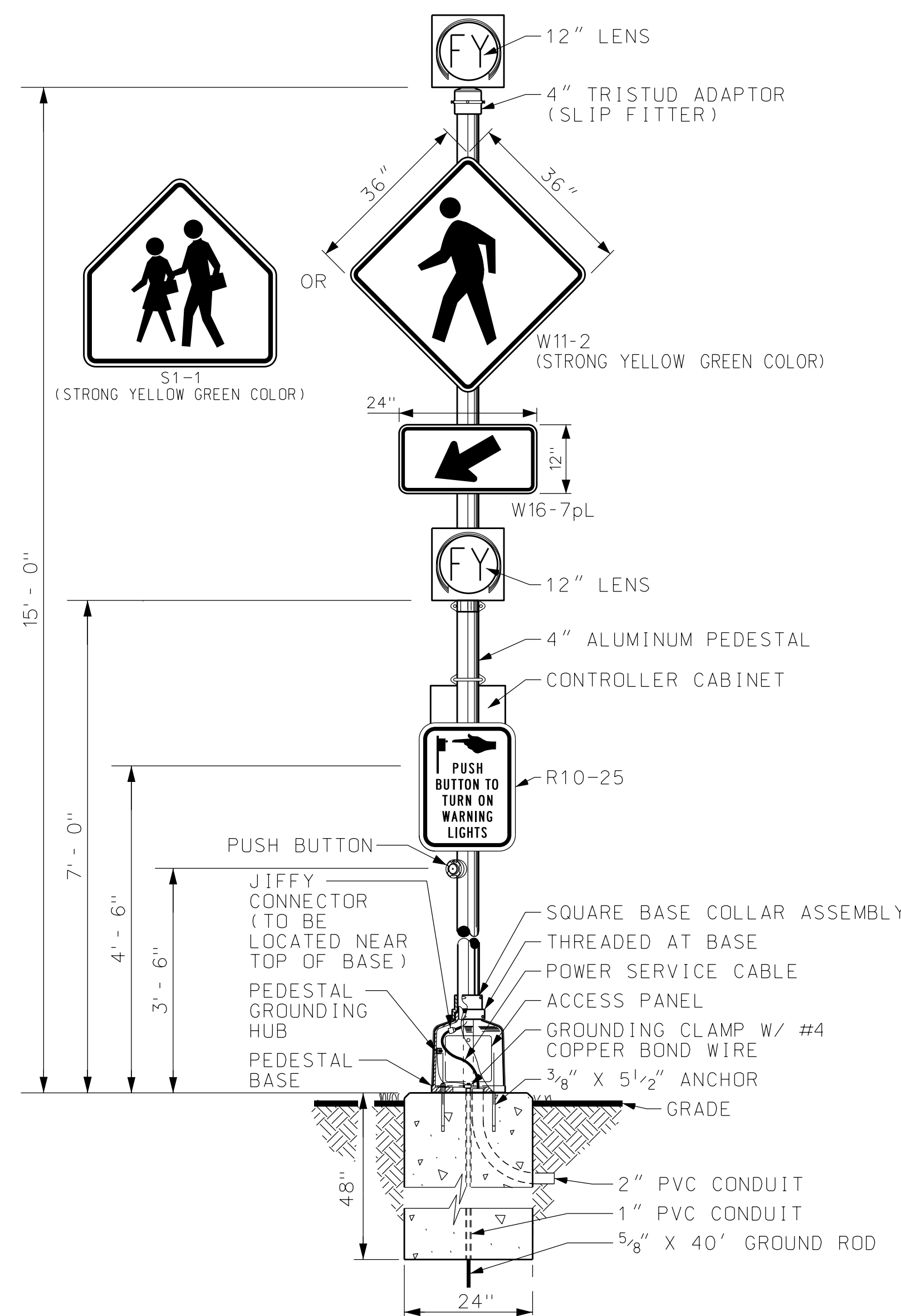

PED FLASHER DETAIL

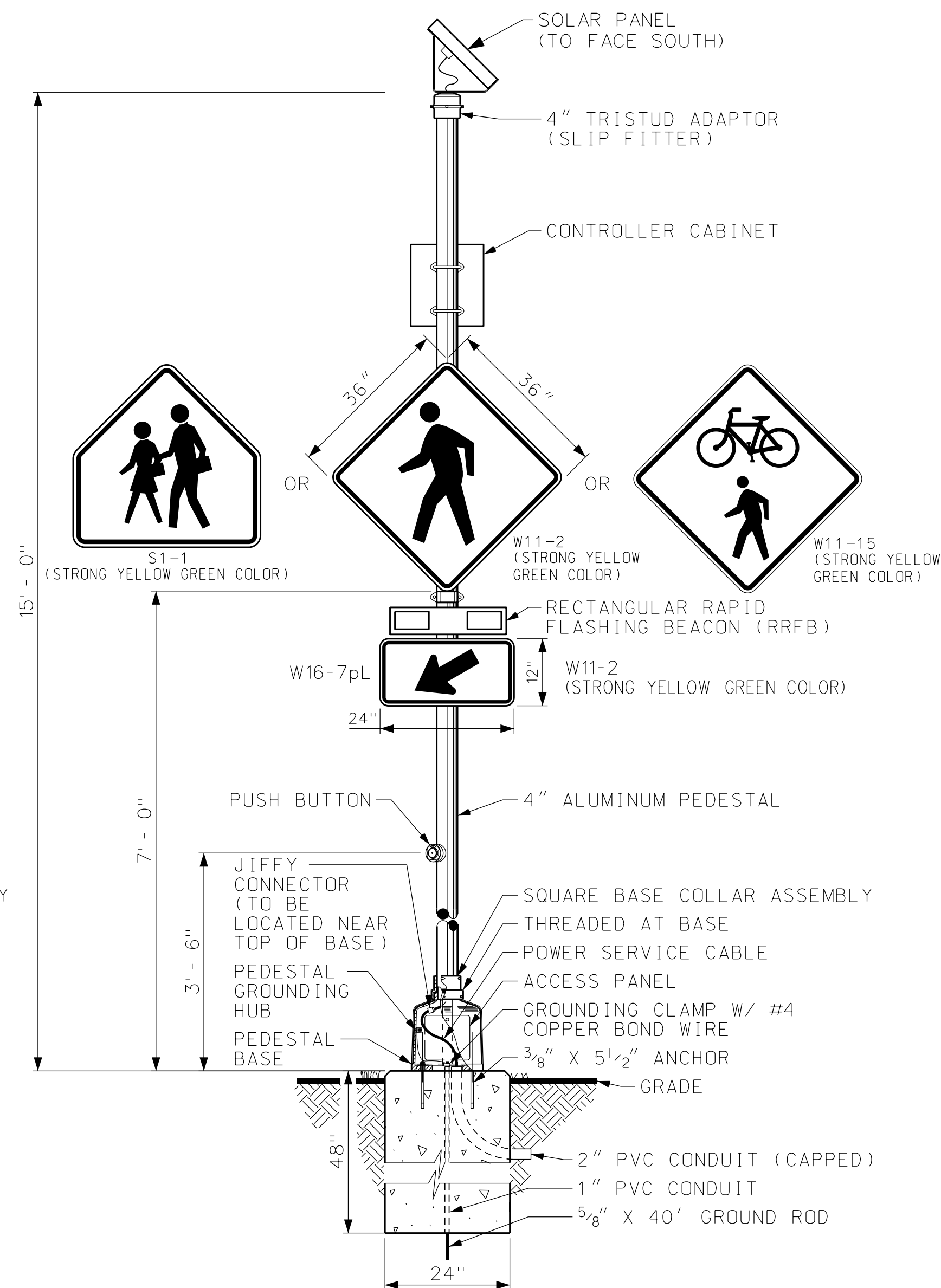

RECTANGULAR RAPID FLASHING BEACON DETAIL (RRFB)

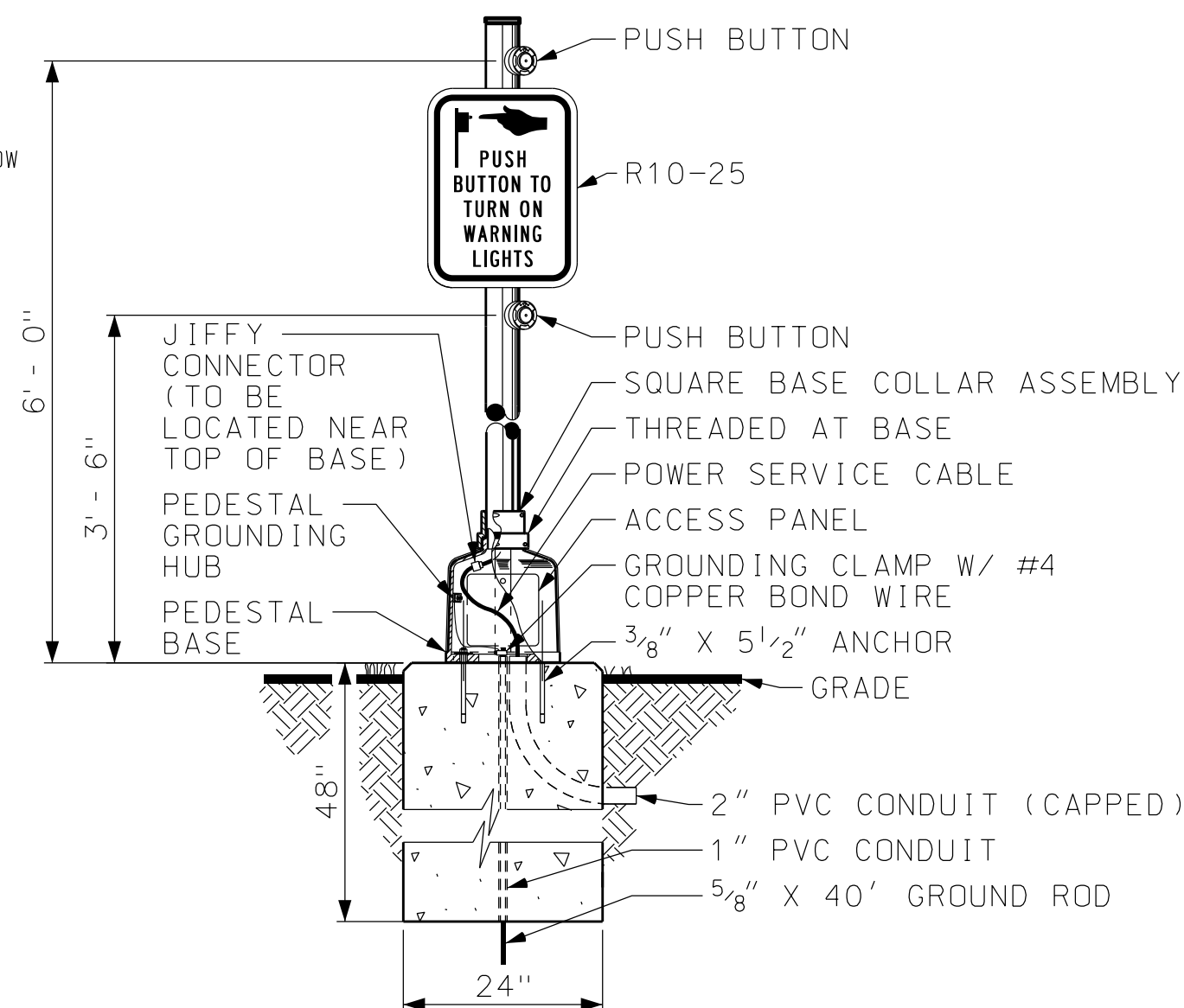

EQUESTRIAN CROSSING FLASHER DETAIL

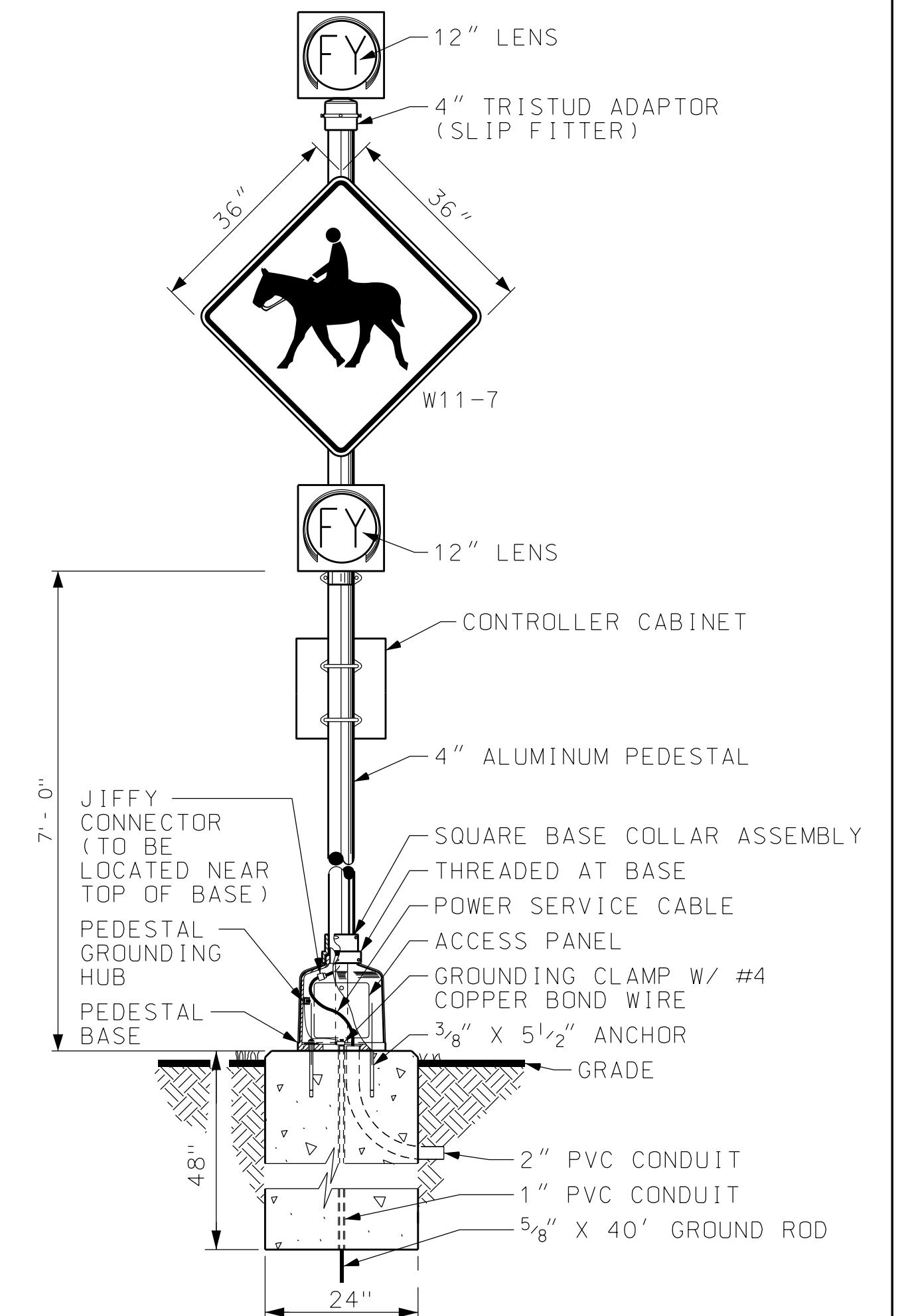

- GENERAL NOTES:**
1. THIS DRAWING IS NOT TO SCALE.
 2. DESIGN, LAYOUT & DATA ON THIS SHEET ARE FOR ILLUSTRATION PURPOSE ONLY.

**PALM BEACH COUNTY, FLORIDA
TRAFFIC DIVISION
SIGNAL TYPICAL**

**PED, RECTANGULAR RAPID BEACON,
& EQUESTRIAN FLASHER DETAIL**

SIGNATURE: *Fatme N. Jafar* DATE: _____ FATMEH N. JAFAR
ENGINEER OF RECORD
DRAWN BY: _____ NAME: _____ DATE: _____ SCALE: _____ CONTRACT NO.: _____
CHECKED BY: _____ N. T. S.

| NO. | DATE | REVISIONS | BY | APP. |
|------------------------------|------|-----------|----|------|
| DRAWING T-8.1 SHEET 19 OF 28 | | | | |

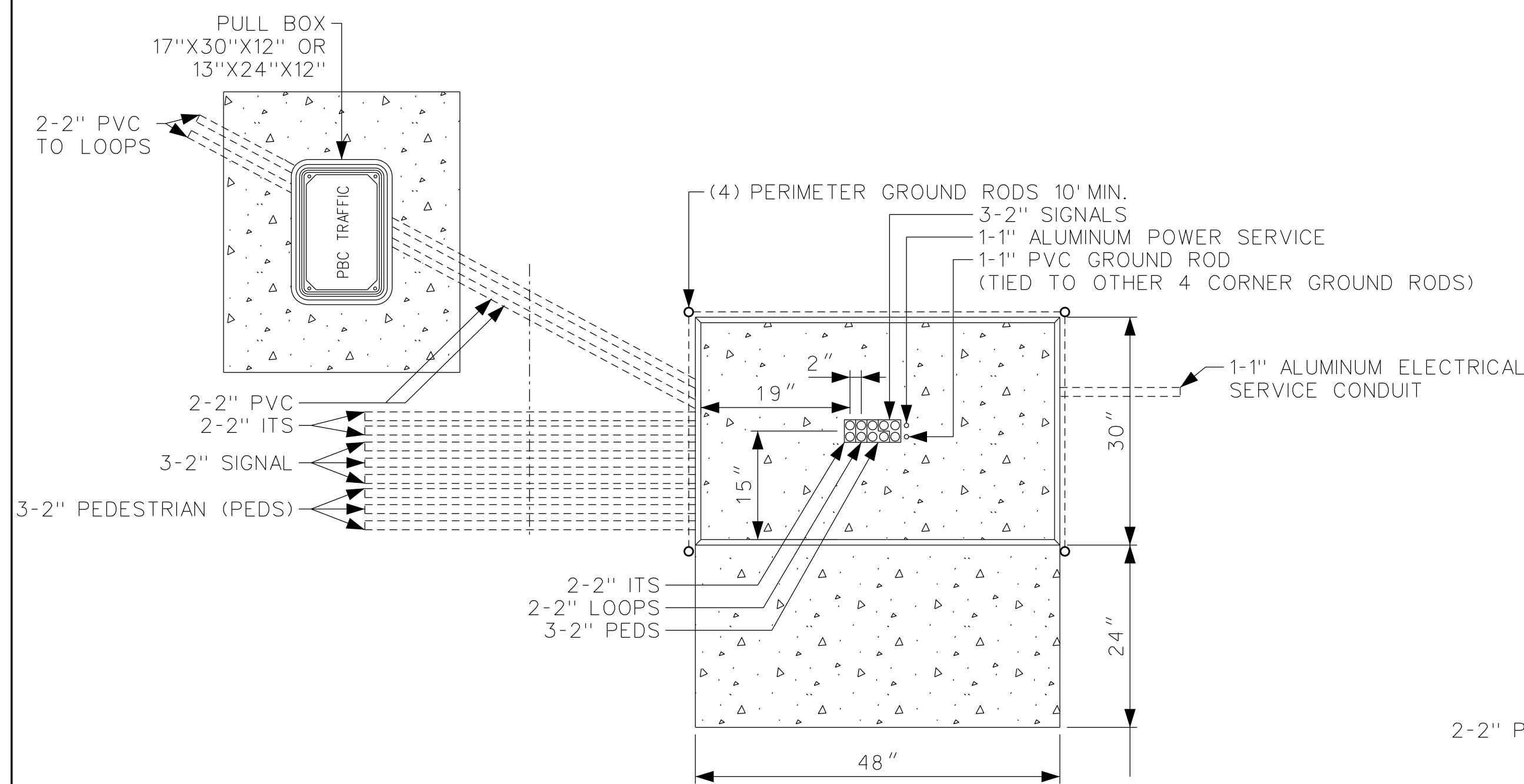

PLAN VIEW

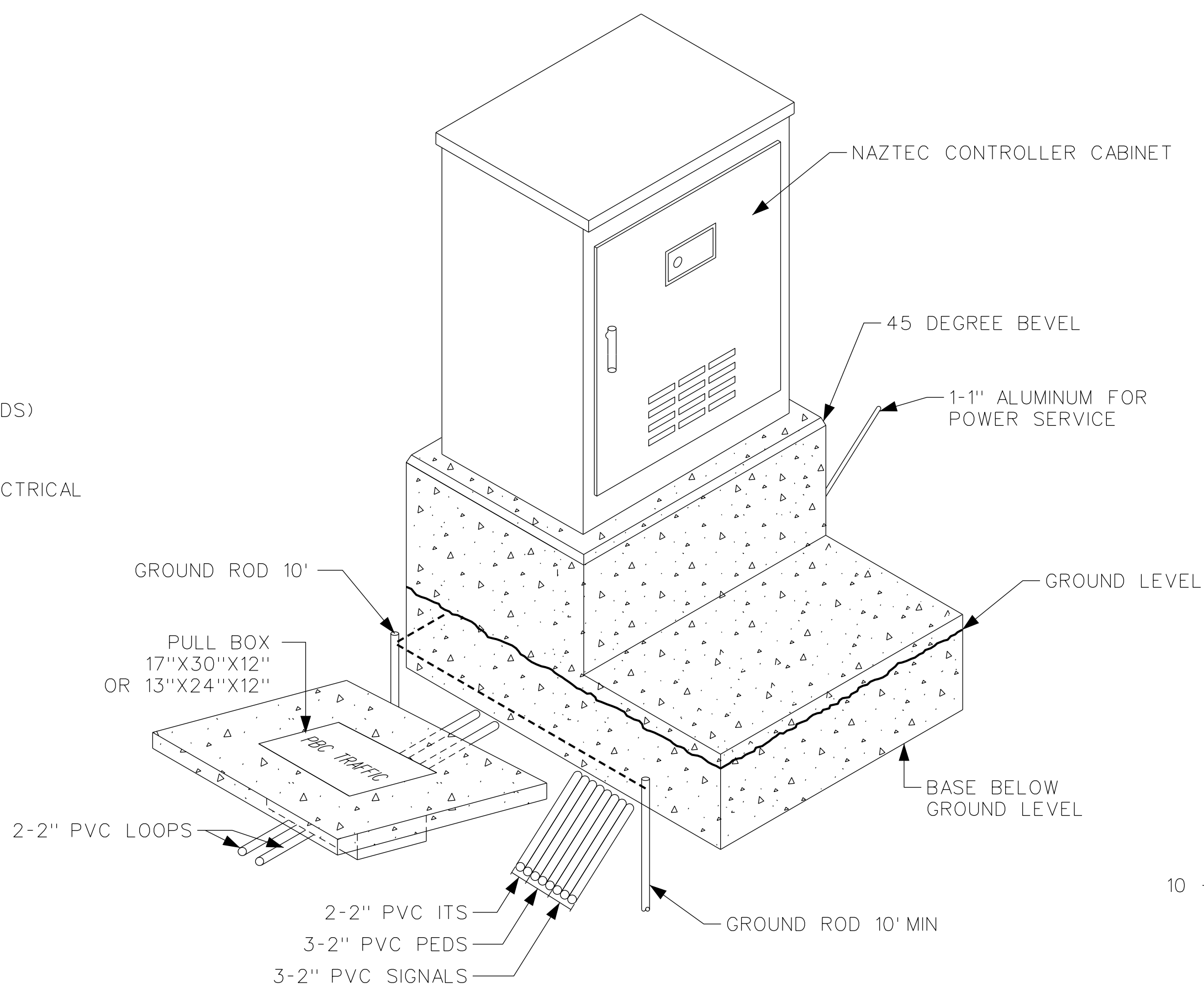

ISOMETRIC VIEW

NOTES:

- 2" CONDUIT WILL EXTEND BEYOND THE CONTROLLER BASE IN THE PULL BOX (SIZE 17"X30"X12" OR 13"X24"X12").
- ALL DUCTS SHALL BE SEALED WITH PERGUM OR EQUAL SUBSTANCE.
- USE NAZTEC CONTROLLER ASSEMBLIES:
 A.) TYPE 4 CABINET FOR FIRE-STATION.
 B.) TYPE 6 CABINET FOR ALL INTERSECTIONS AND ALL NEW INSTALLATIONS.
 C.) TYPE 5 CABINET PER PBC APPROVAL.
- BASE SIZES FOR ALL CABINETS AS SHOWN.

TYPICAL GROUND ROD ARRAY

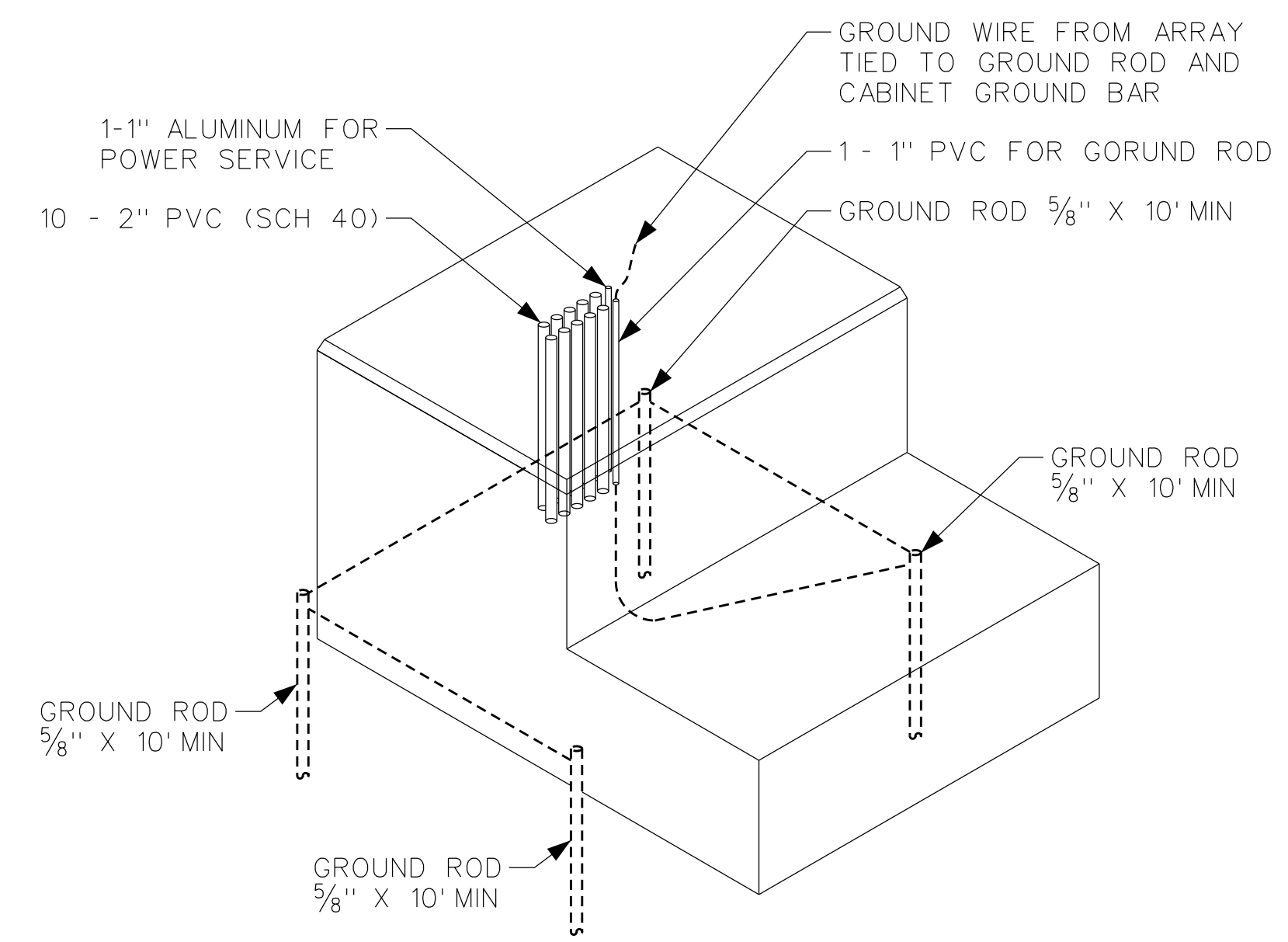

GROUND ROD NOTES:

- FOUR (4) PERIMETER GROUND RODS SHALL BE BONDED AND BURIED WITH TOP OF ROD 6" BELOW GROUND LEVEL, 10 FT. LENGTH PER ROD MINIMUM.
- FOR GROUND ROD INFORMATION SEE NOTES ON T-6.3.

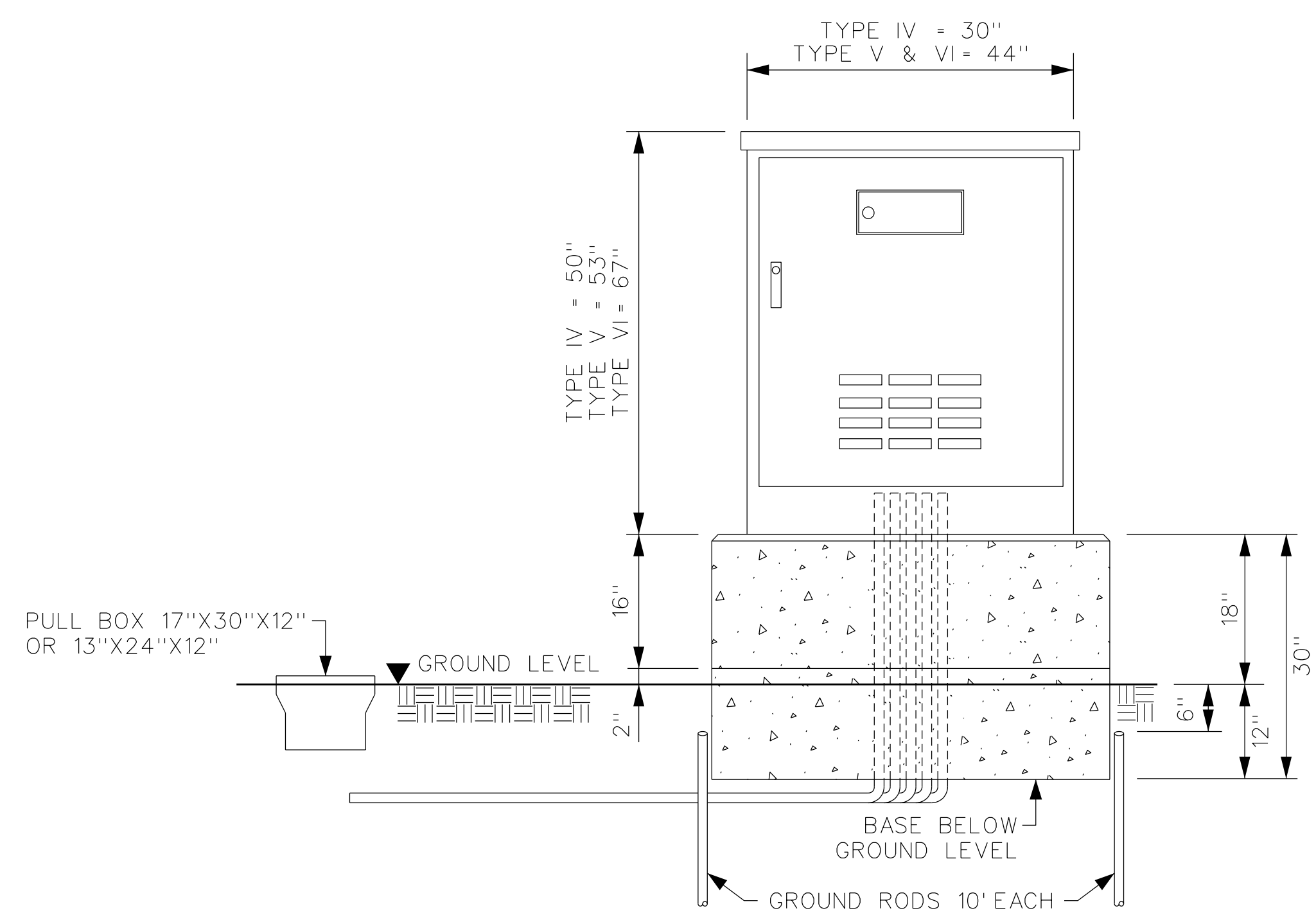

FRONT VIEW

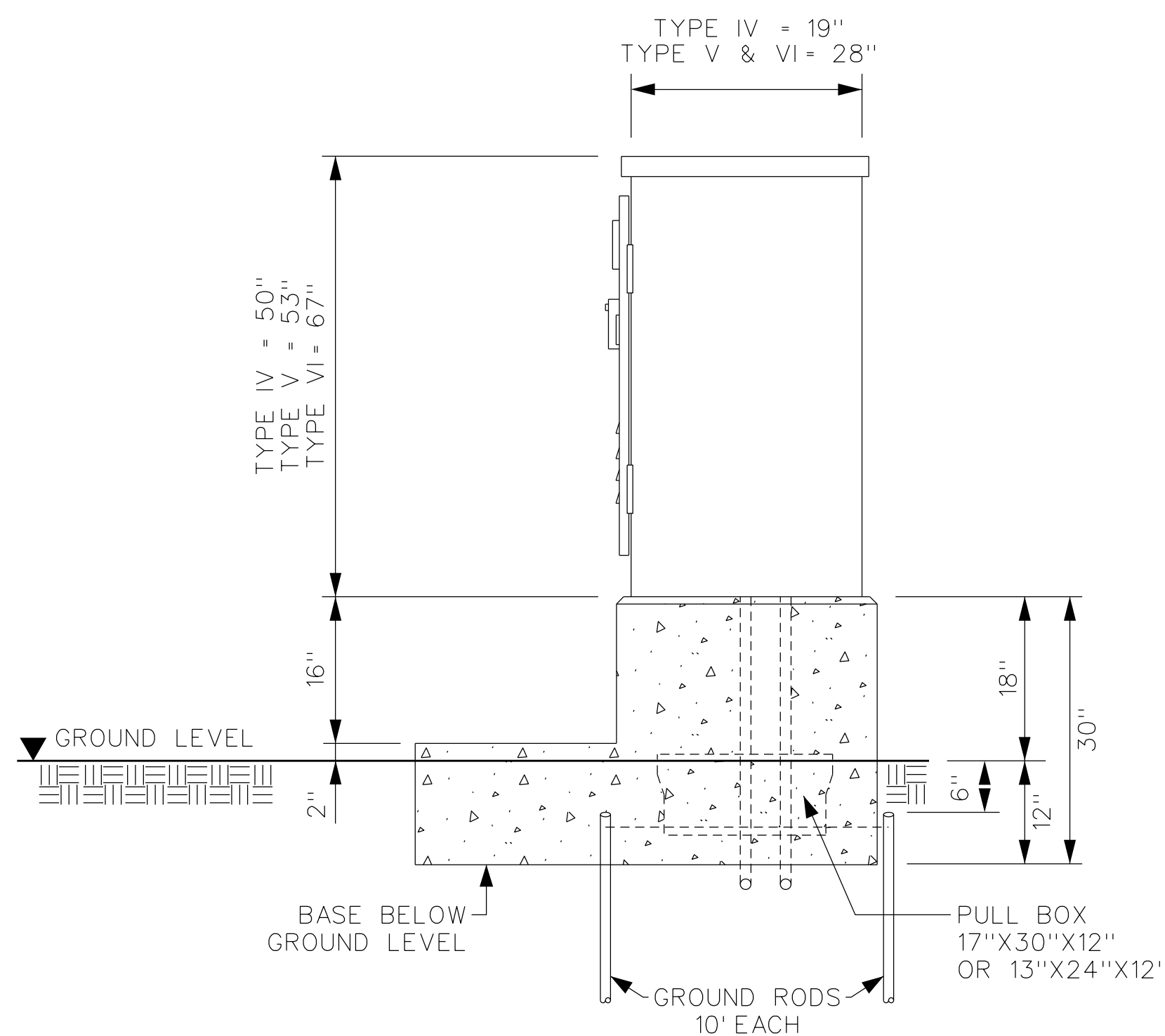

RIGHT-SIDE VIEW

CABINET & FOUNDATION DETAIL

GENERAL NOTES:

- THIS DRAWING IS NOT TO SCALE.
- DESIGN, LAYOUT & DATA ON THIS SHEET ARE FOR ILLUSTRATION PURPOSE ONLY.

**PALM BEACH COUNTY, FLORIDA
 TRAFFIC DIVISION
 SIGNAL TYPICAL**

**CABINET & FOUNDATION DETAIL,
 TYPICAL GROUND ROD ARRAY**

| | | | | | |
|------------|------|------|----------|---------------------------------------|--|
| SIGNATURE | | DATE | | FATMEH N. JAFAR ENGINEER OF RECORD | |
| DRAWN BY | NAME | DATE | SCALE | CONTRACT NO. | |
| CHECKED BY | | | N. T. S. | | |

| NO. | DATE | REVISIONS | BY | APP. |
|-----|------|-----------|----|------|
| | | | | |

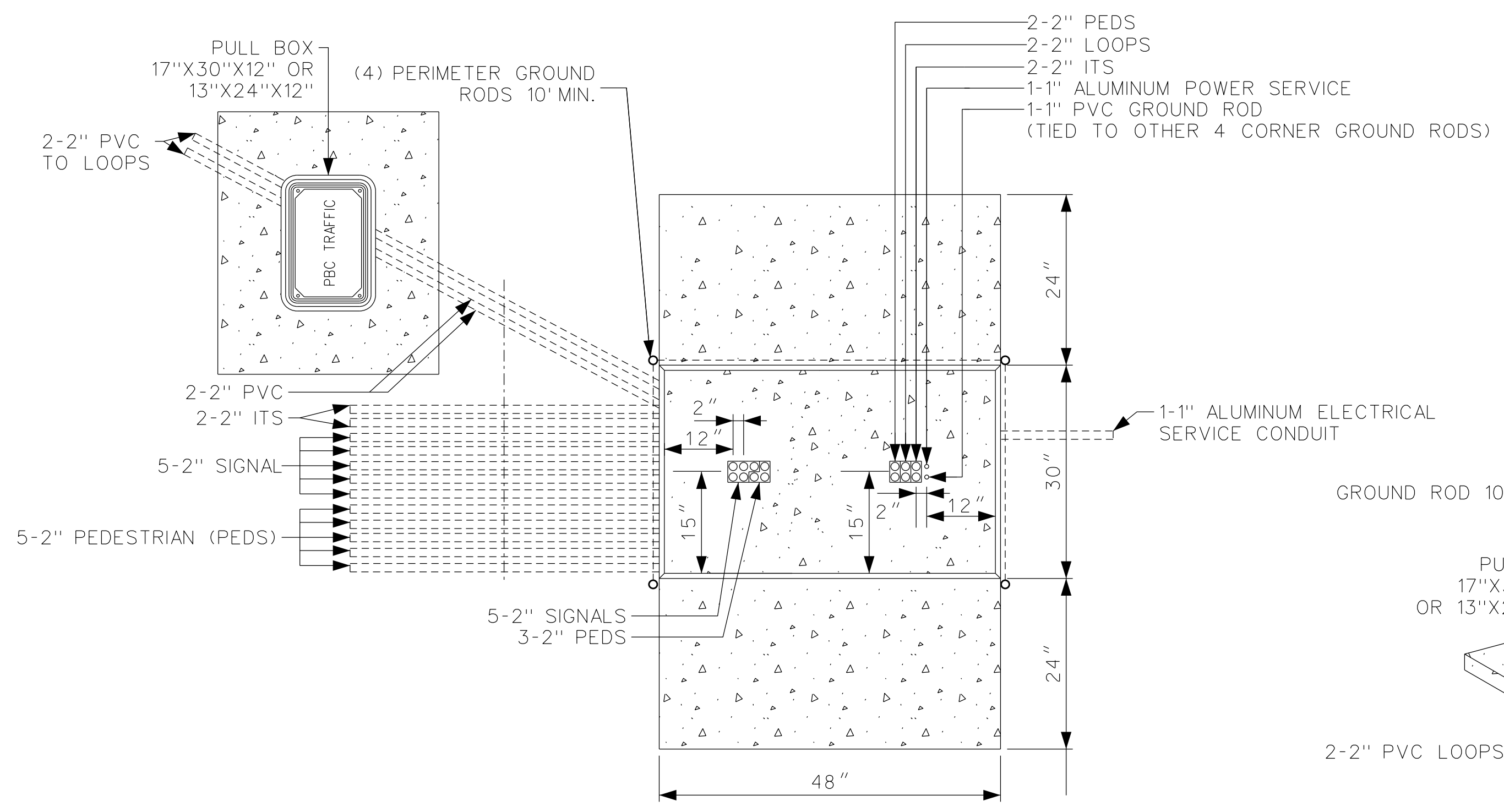

PLAN VIEW

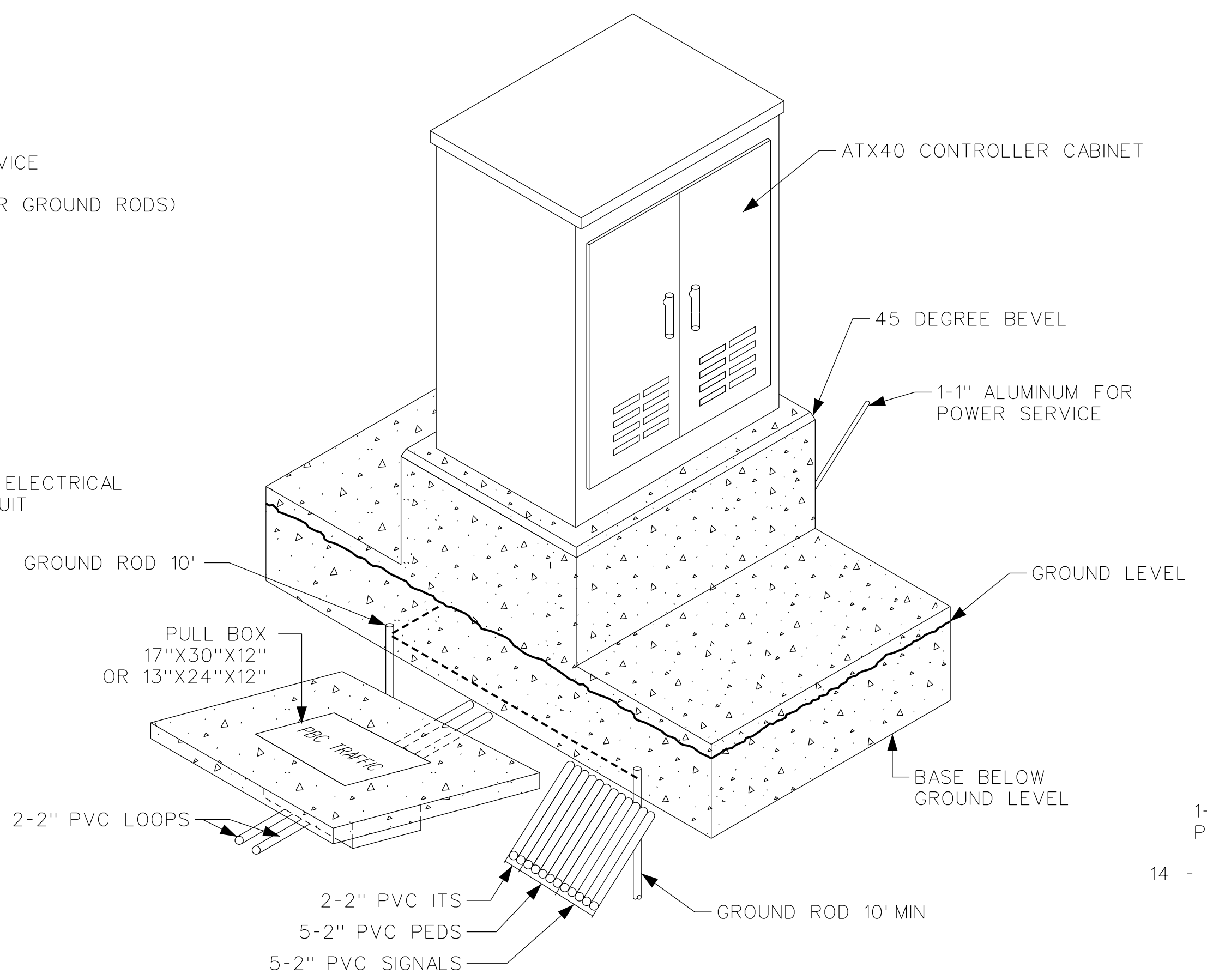

ISOMETRIC VIEW

GROUND ROD ARRAY

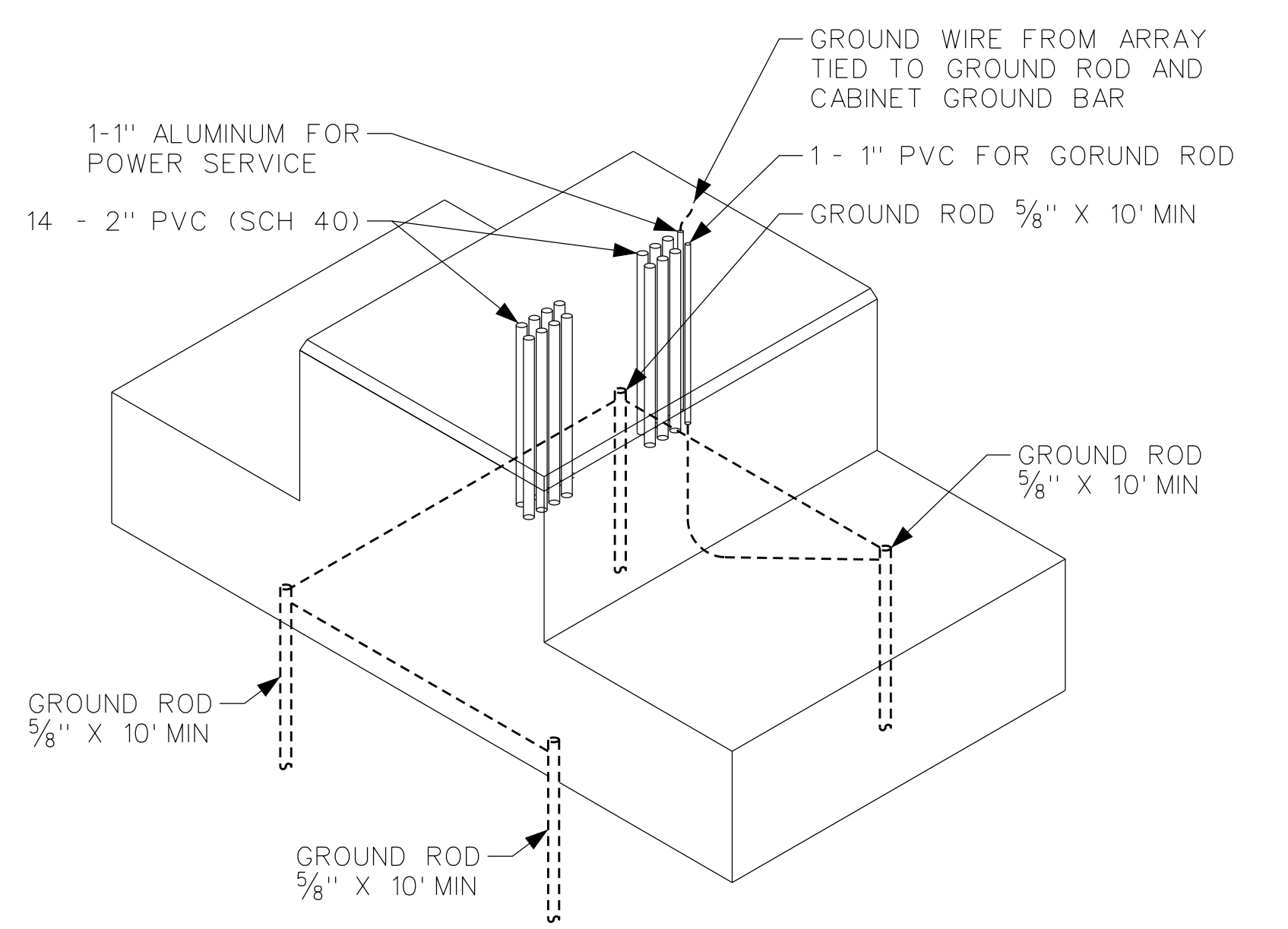

GROUND ROD NOTES:

1. FOUR (4) PERIMETER GROUND RODS SHALL BE BONDED AND BURIED WITH TOP OF ROD 6\"/>
- 2. FOR GROUND ROD INFORMATION SEE NOTES ON T-6.3.

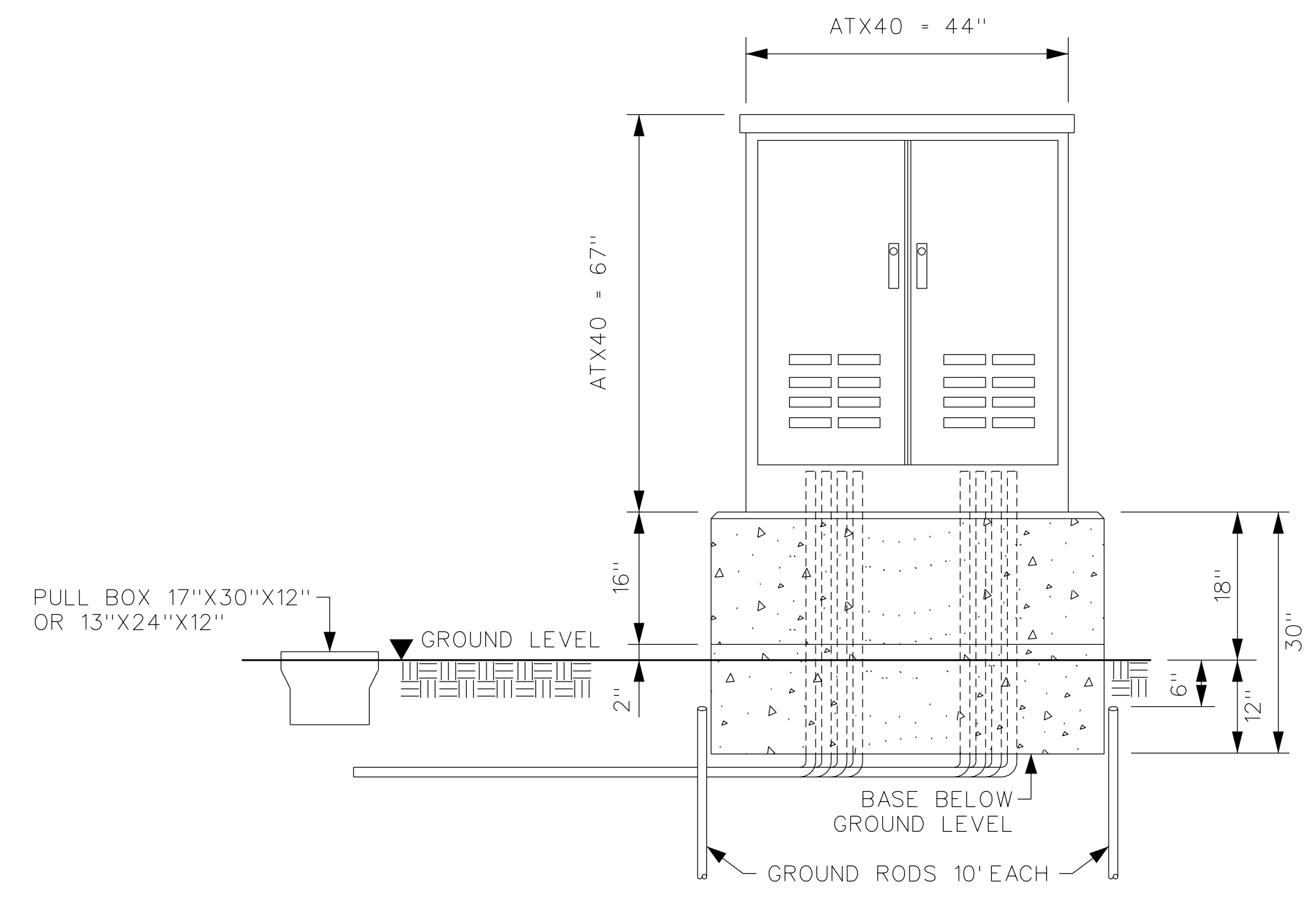

FRONT VIEW

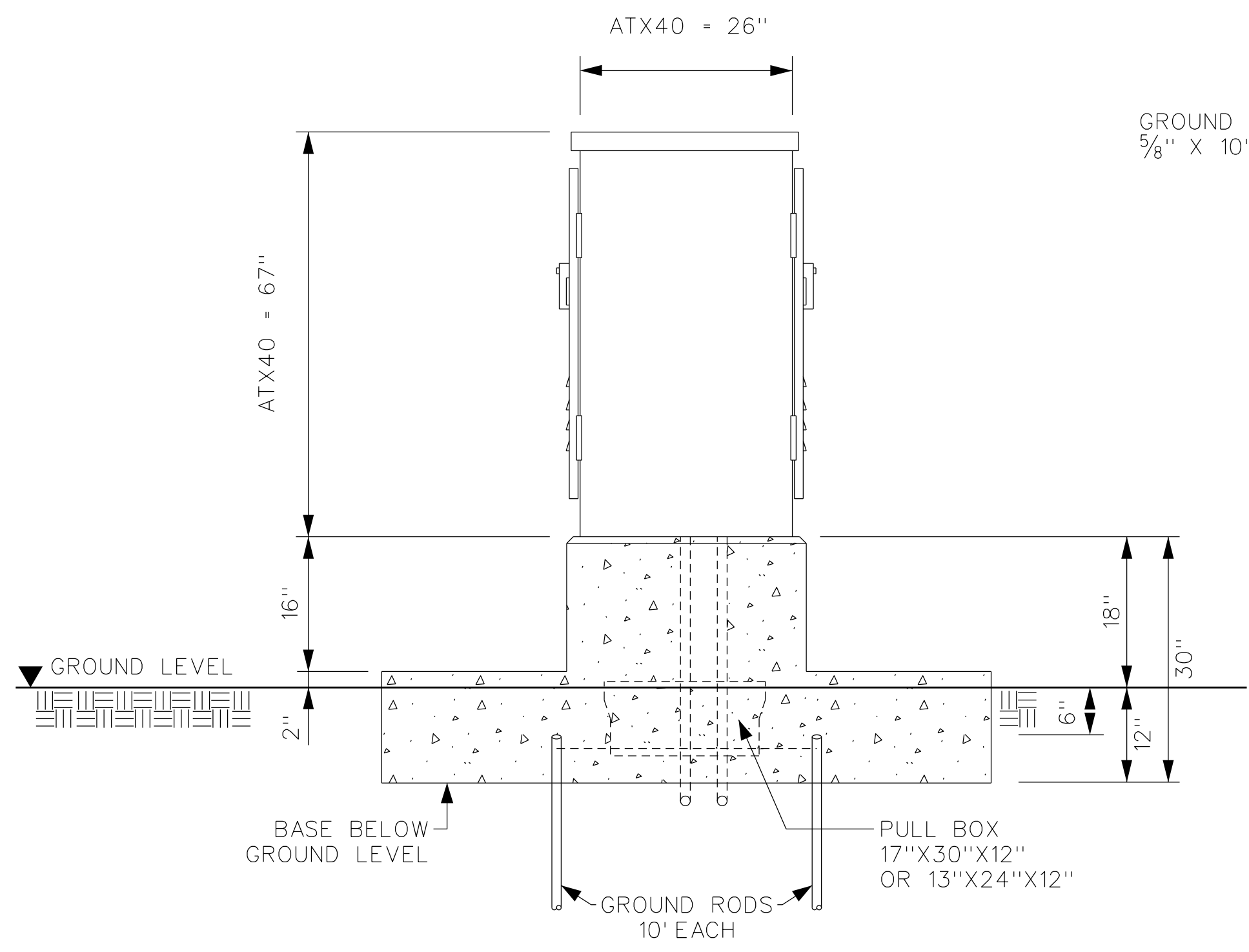

RIGHT-SIDE VIEW

ATX40 CABINET & FOUNDATION DETAIL

GENERAL NOTES:
 1. THIS DRAWING IS NOT TO SCALE.
 2. DESIGN, LAYOUT & DATA ON THIS SHEET ARE FOR ILLUSTRATION PURPOSE ONLY.

**PALM BEACH COUNTY, FLORIDA
 TRAFFIC DIVISION
 SIGNAL TYPICAL**

ATX40 CABINET & FOUNDATION
 DETAIL, GROUND ROD ARRAY

SIGNATURE: *Fatme N. Jafar* DATE: FATMEH N. JAFAR
 ENGINEER OF RECORD
 DRAWN BY: NAME DATE SCALE CONTRACT NO.
 CHECKED BY: N. T. S.

| NO. | DATE | REVISIONS | BY | APP. |
|-----|------|-----------|----|------|
| | | | | |

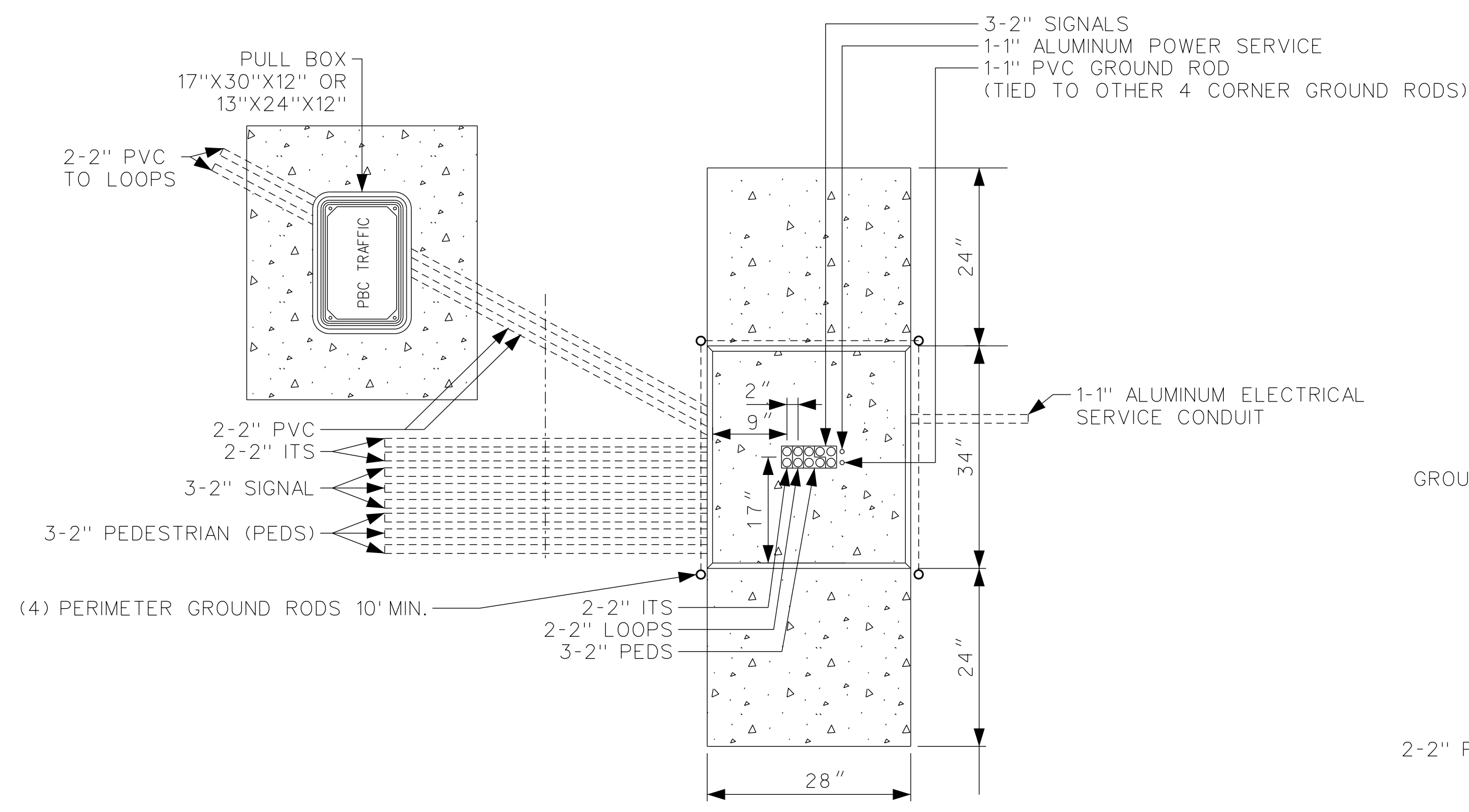

PLAN VIEW

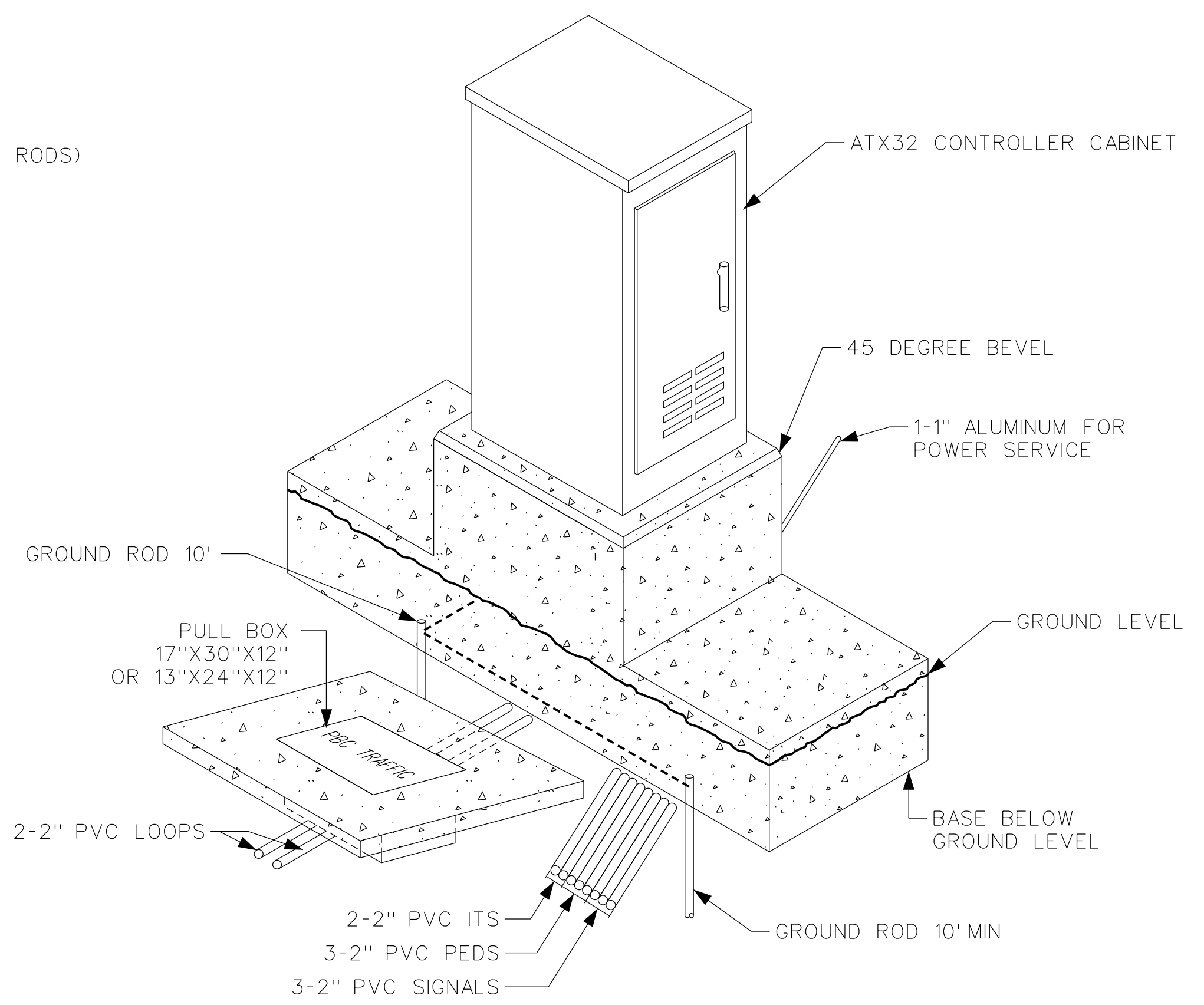

ISOMETRIC VIEW

GROUND ROD ARRAY

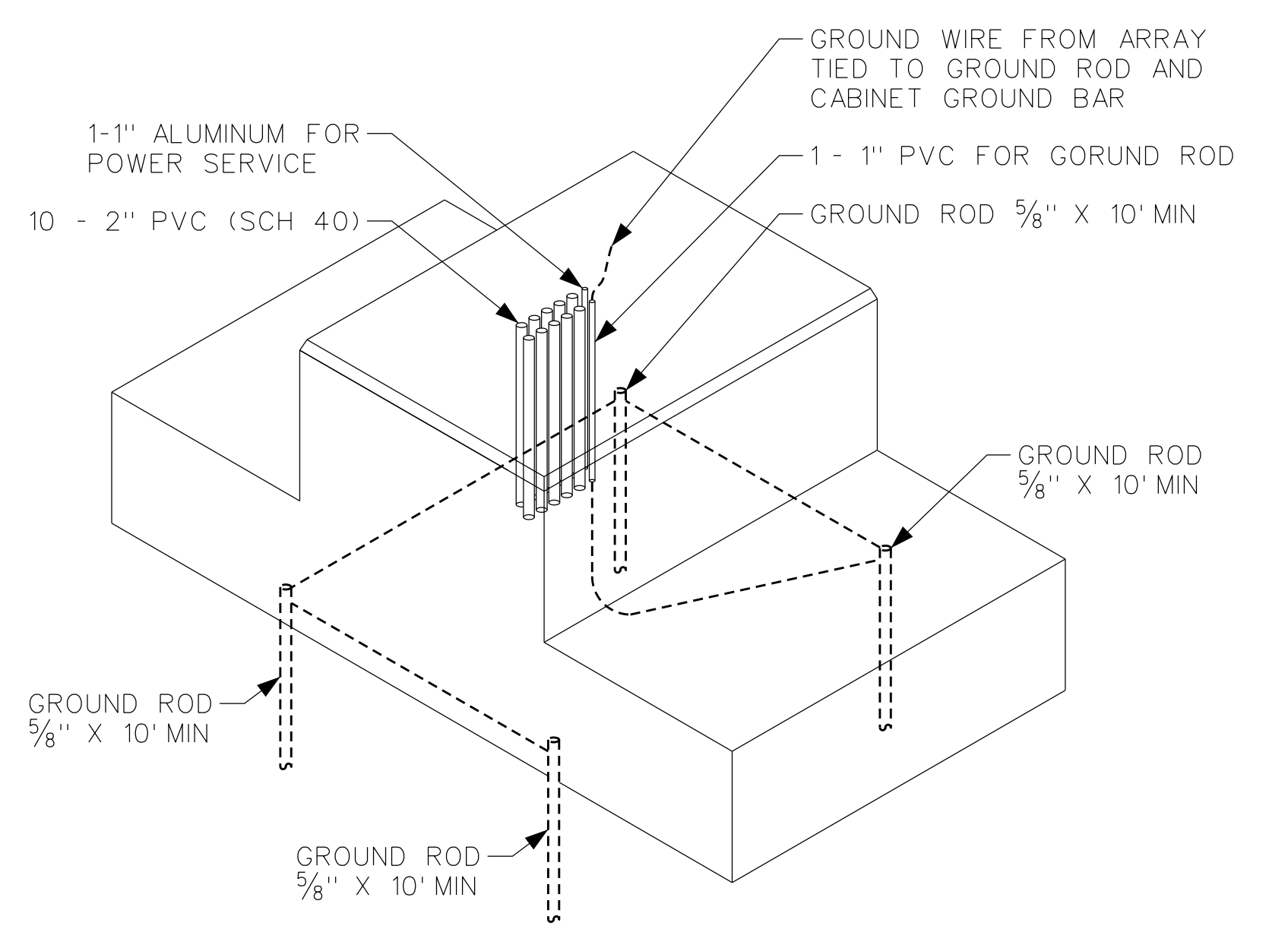

GROUND ROD NOTES:

1. FOUR (4) PERIMETER GROUND RODS SHALL BE BONDED AND BURIED WITH TOP OF ROD 6\"/>
- 2. FOR GROUND ROD INFORMATION SEE NOTES ON T-6.3.

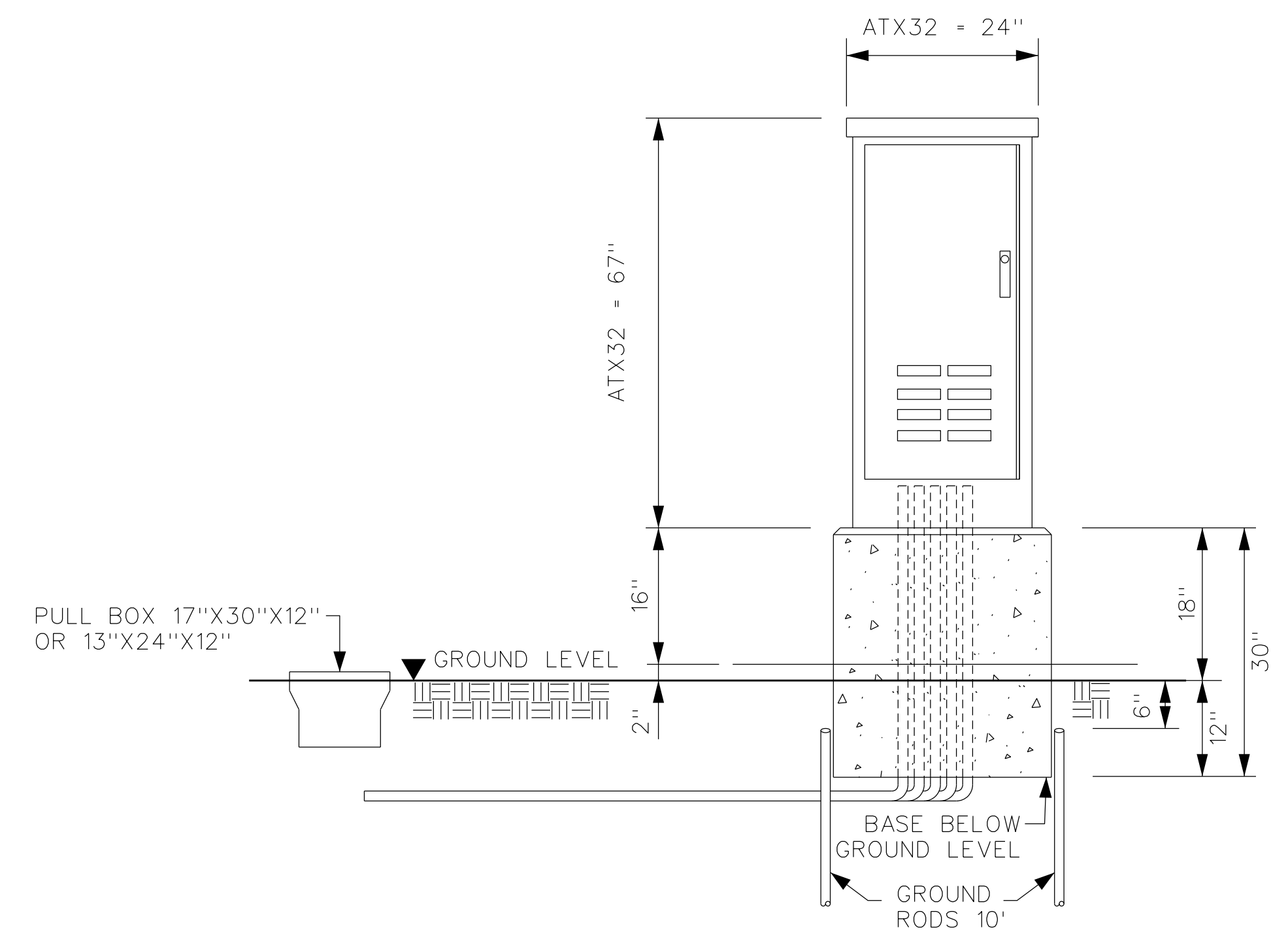

FRONT VIEW

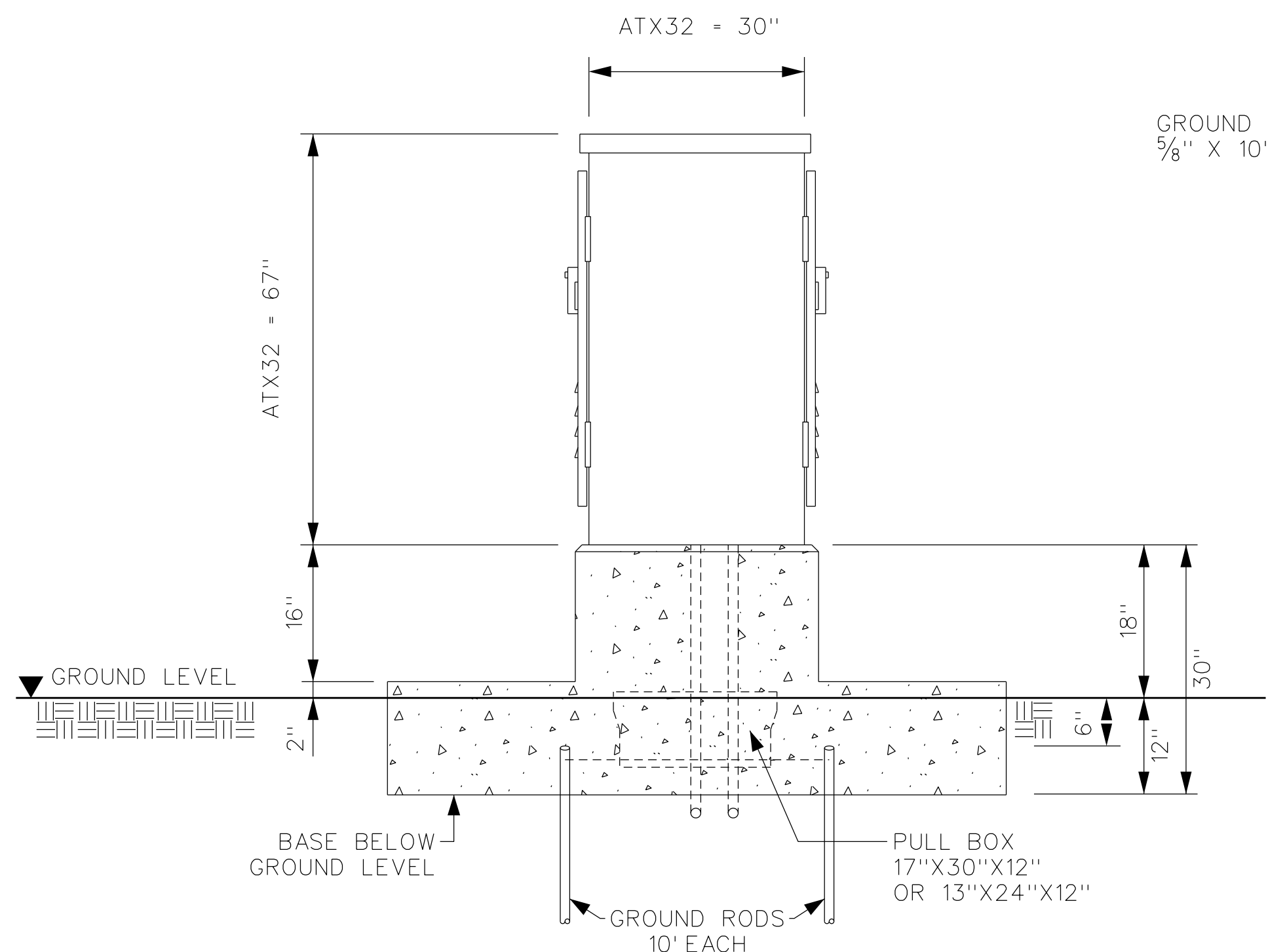

RIGHT-SIDE VIEW

ATX32 CABINET & FOUNDATION DETAIL

GENERAL NOTES:
 1. THIS DRAWING IS NOT TO SCALE.
 2. DESIGN, LAYOUT & DATA ON THIS SHEET ARE FOR ILLUSTRATION PURPOSE ONLY.

**PALM BEACH COUNTY, FLORIDA
 TRAFFIC DIVISION
 SIGNAL TYPICAL**

ATX32 CABINET & FOUNDATION
 DETAIL, GROUND ROD ARRAY

SIGNATURE: *Fatme N. Jafar* DATE: _____ FATMEH N. JAFAR
 ENGINEER OF RECORD
 DRAWN BY: _____ DATE: _____ SCALE: _____ CONTRACT NO. _____
 CHECKED BY: _____ N. T. S.

| NO. | DATE | REVISIONS | BY | APP. |
|-----|------|-----------|----|------|
| | | | | |

ILLUMINATED STREET NAME SIGN TYPICAL (LONG NAME)
ILLUMINATED STREET NAME SIGN TYPICAL (SHORT NAME)

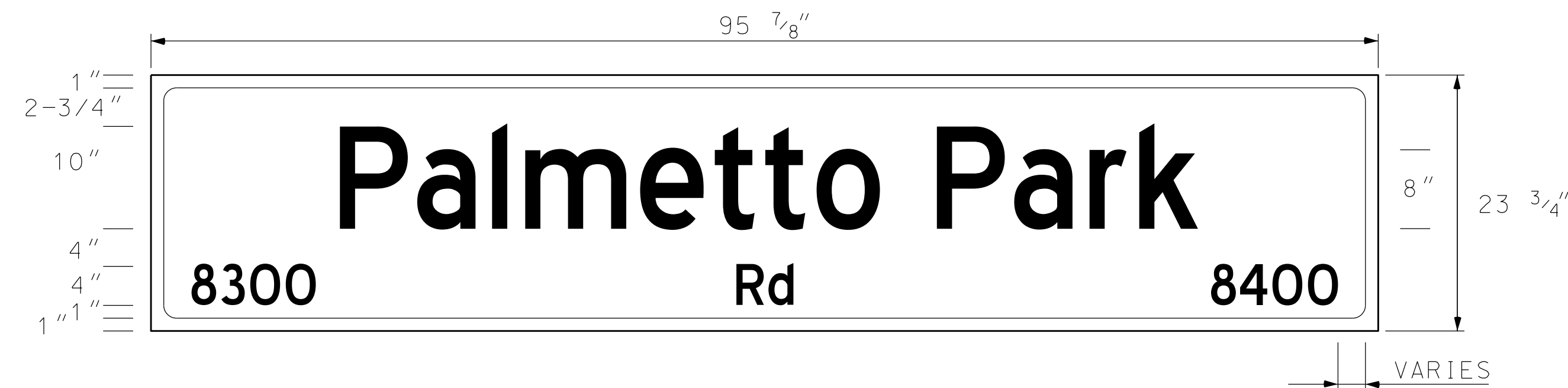

ILLUMINATED STREET NAME SIGN TYPICAL (LONG NAME)
DIVIDED STREET NAME OR T-INTERSECTION
ADD BLOCK NUMBER ON THE SAME SIDE AS INTERSECTING STREET



ILLUMINATED STREET NAME SIGN TYPICAL (SHORT NAME)

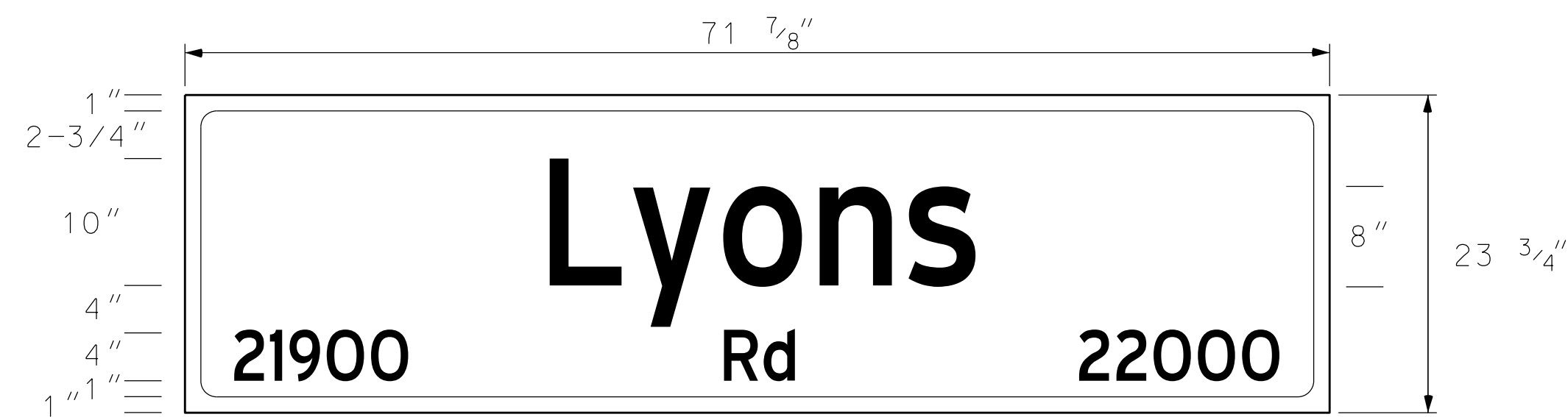

ILLUMINATED STREET NAME SIGN TYPICAL (SHORT NAME)
DIVIDED STREET NAME OR T-INTERSECTION
ADD BLOCK NUMBER ON THE SAME SIDE AS INTERSECTING STREET

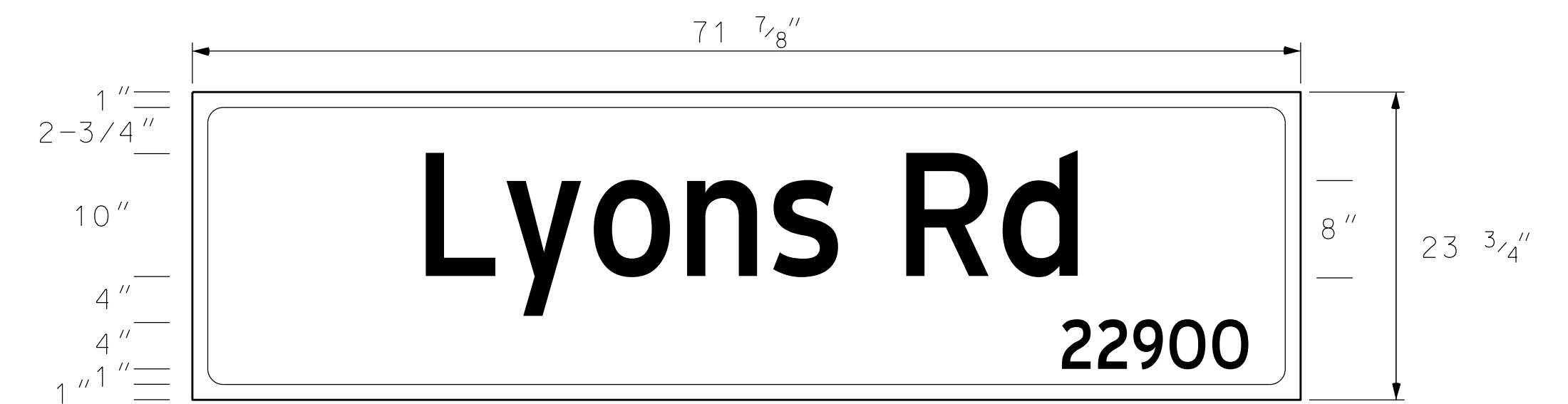

ILLUMINATED STREET NAME SIGN TYPICAL (LONG NAME)
AT EAST / WEST AND NORTH / SOUTH DIVIDING STREETS
ALT. DISPLAY: USE E, W, N OR S TO INDICATE DIRECTION WHEN BLOCK NUMBERS NOT APPLICABLE

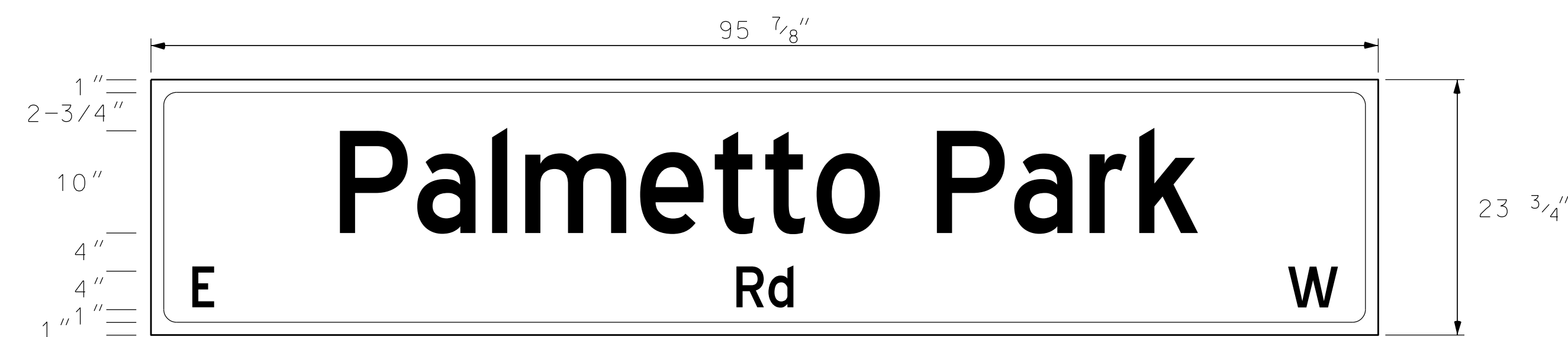

ILLUMINATED STREET NAME SIGN TYPICAL (SHORT NAME)
ALT. DISPLAY: DIRECTIONAL ARROW FOR DIVIDED STREET NAME OR T-INTERSECTION
WHEN BLOCK NUMBERS NOT APPLICABLE

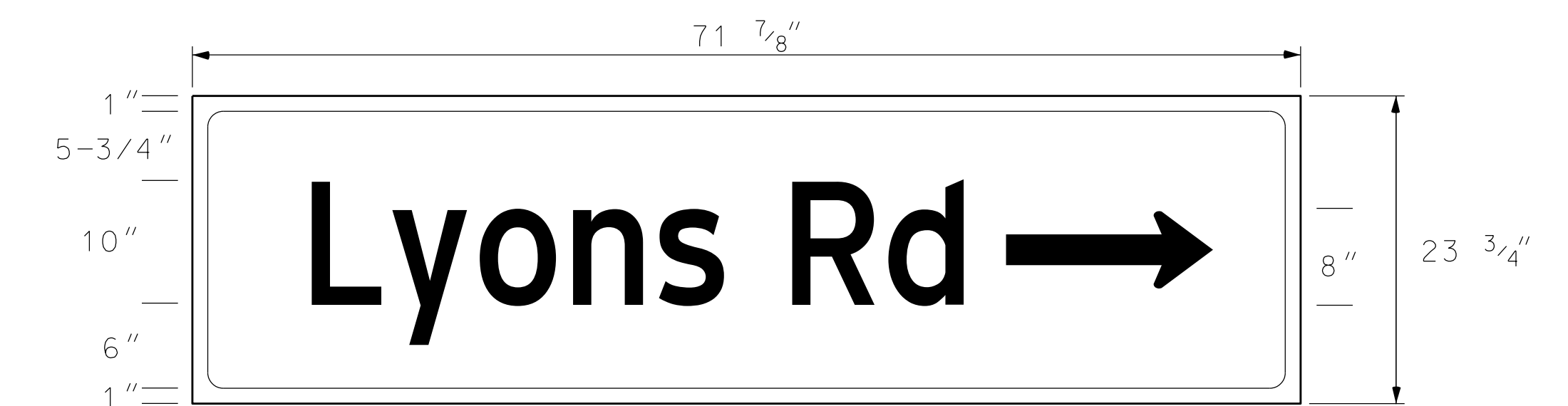

NOTES:

- 1.) USE UPPERCASE AND LOWERCASE STANDARD HIGHWAY ALPHABET SERIES FONT.
- 2.) 10" STANDARD FONT SIZE (ADJUST AS NEEDED).
- 3.) ILLUMINATED STREET NAME SIGNS TO BE INSTALLED WITH ALL MAST ARM INSTALLATIONS.
- 4.) ILLUMINATED STREET NAME SIGNS TO BE DOUBLE SIDED FREE SWINGING.
- 5.) ILLUMINATED STREET NAME SIGN FACES SHALL BE TRANSLUCENT LENSES AND THE BACKGROUND MUST HAVE TRANSLUCENT RETROREFLECTIVE SHEETING
- 6.) EACH SIGN SHALL HAVE A SEPARATE CABLE BACK TO THE BREAKER.
- 7.) EACH SIGN SHALL HAVE A SEPARATE PHOTOCELL.
- 8.) SHOP DRAWINGS SHALL BE SUBMITTED TO PBC TRAFFIC ENGINEER FOR APPROVAL.

GENERAL NOTES:

1. THIS DRAWING IS NOT TO SCALE.
2. DESIGN, LAYOUT & DATA ON THIS SHEET ARE FOR ILLUSTRATION PURPOSE ONLY.

PALM BEACH COUNTY, FLORIDA
TRAFFIC DIVISION
SIGNAL TYPICAL

ILLUMINATED STREET
NAME SIGN DETAIL

| | | | | |
|---------------------------------------|------|------|----------|--------------|
| SIGNATURE | NAME | DATE | SCALE | CONTRACT NO. |
| <i>Fatme N. Jafar</i> | | | N. T. S. | |
| FATMEH N. JAFAR ENGINEER OF RECORD | | | | |

| NO. | DATE | REVISIONS | BY | APP. |
|-----|------|-----------|----|------|
| | | | | |

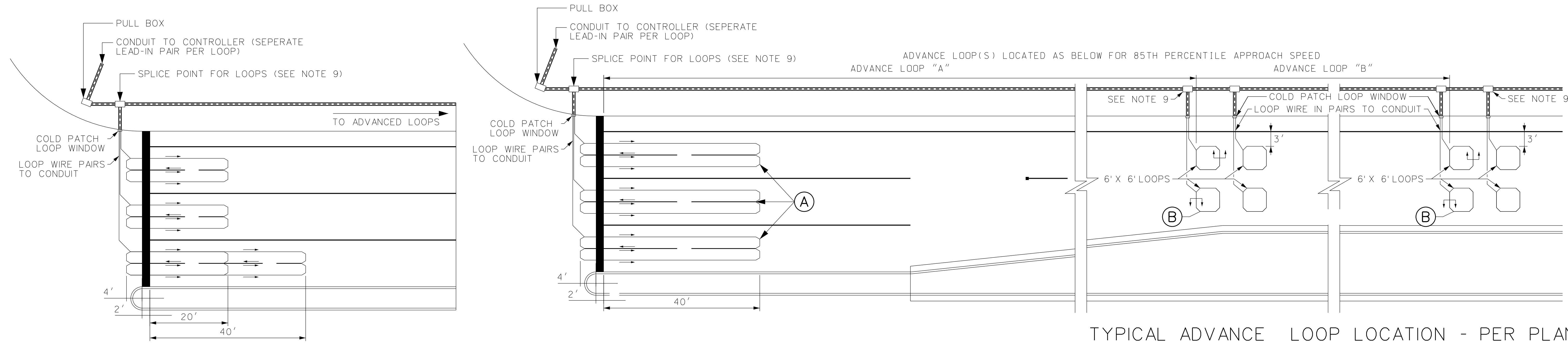

TYPICAL 26' AND 46' STOP BAR LOOP LOCATION

TYPICAL ADVANCE LOOP LOCATION - PER PLAN

NOTES:

1. LOOP WIRE 14 AWG XHHW WITH STRANDED CROSS-LINKED POLYETHYLENE INSULATION 600 VOLTS N.E.C. STD. (WHITNEY BLAKE TYPE 632-0801).
2. LEAD-IN CABLE SHALL BE 18 AWG TINNED COPPER, TWO CONDUCTOR POLYETHYLENE INSULATED, TWISTED SHIELDED PAIR, STRANDED TINNED COPPER DRAIN WIRE, PVC CHROME VINYL POLYVINYL CHLORIDE JACKET, 300V.
3. LOOP "A" REPRESENTS TYPE F PER FDOT INDEX 17781.
4. SEE DETAIL T-11.1 FOR LOOP LEAD-IN SPLICE.
5. ALL LOOP CORNERS SHALL BE CHAMFERED BY 1 FOOT AT 45 DEGREES.
6. THE DEPTH OF ALL SAW CUTS, EXCEPT ACROSS EXPANSION JOINTS, SHALL BE 3" STANDARD WITH A MAXIMUM OF 4".
7. ALL LOOPS ARE CONNECTED TO CONTROLLER WITH CONDUITS CONNECTING PULL BOXES AT EACH CORNER.
8. LOOP SEALANT SHALL BE LIQUID TAR (HOT STEEP ASPHALT TYPE 4)
9. ALL SPLICES SHALL BE MADE IN PULL BOXES. (TWISTED LOOP WIRE MUST BE BROUGHT TO PULL BOX THEN SPLICED TO LOOP LEAD-IN WIRE).
10. AT INTERSECTIONS WHERE PAVERS ARE BEING INSTALLED CONDUITS MUST BE INSTALLED UNDER THE PAVERS FOR THE LOOP LEAD-INS.

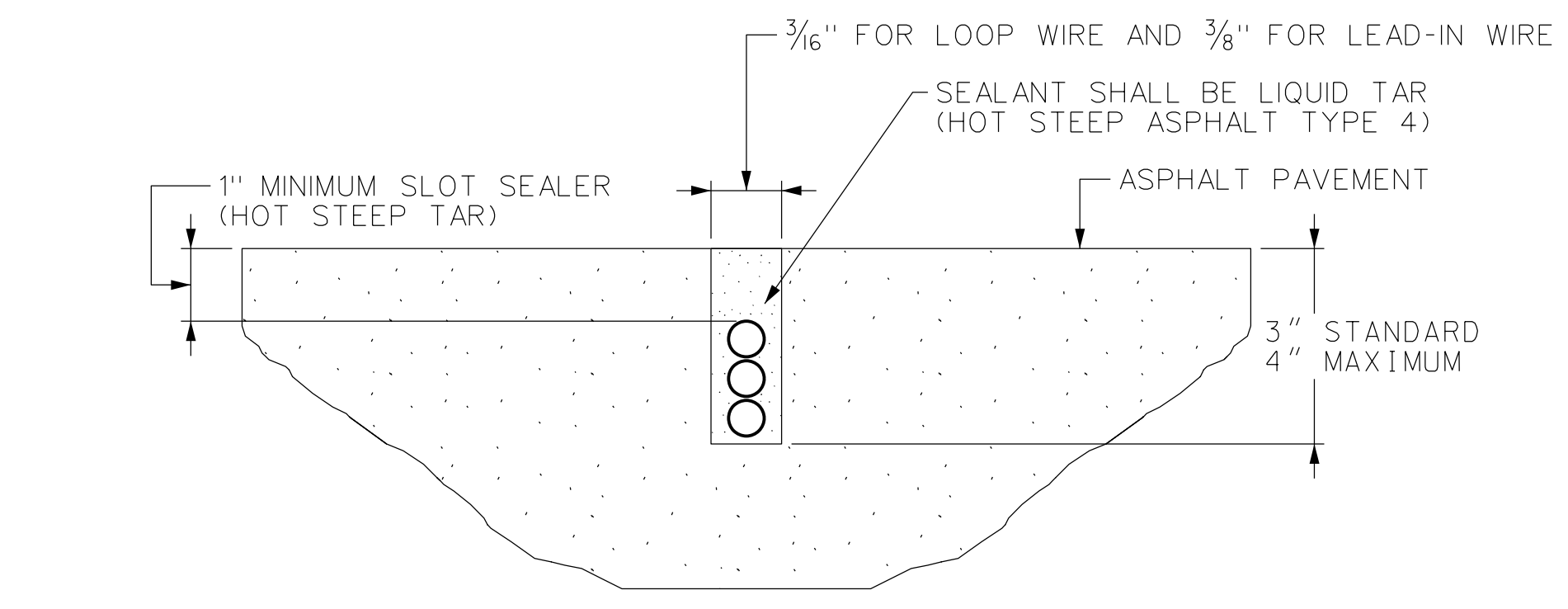

LOOPS AND LEAD-IN HOMERUN WIRES DETAIL

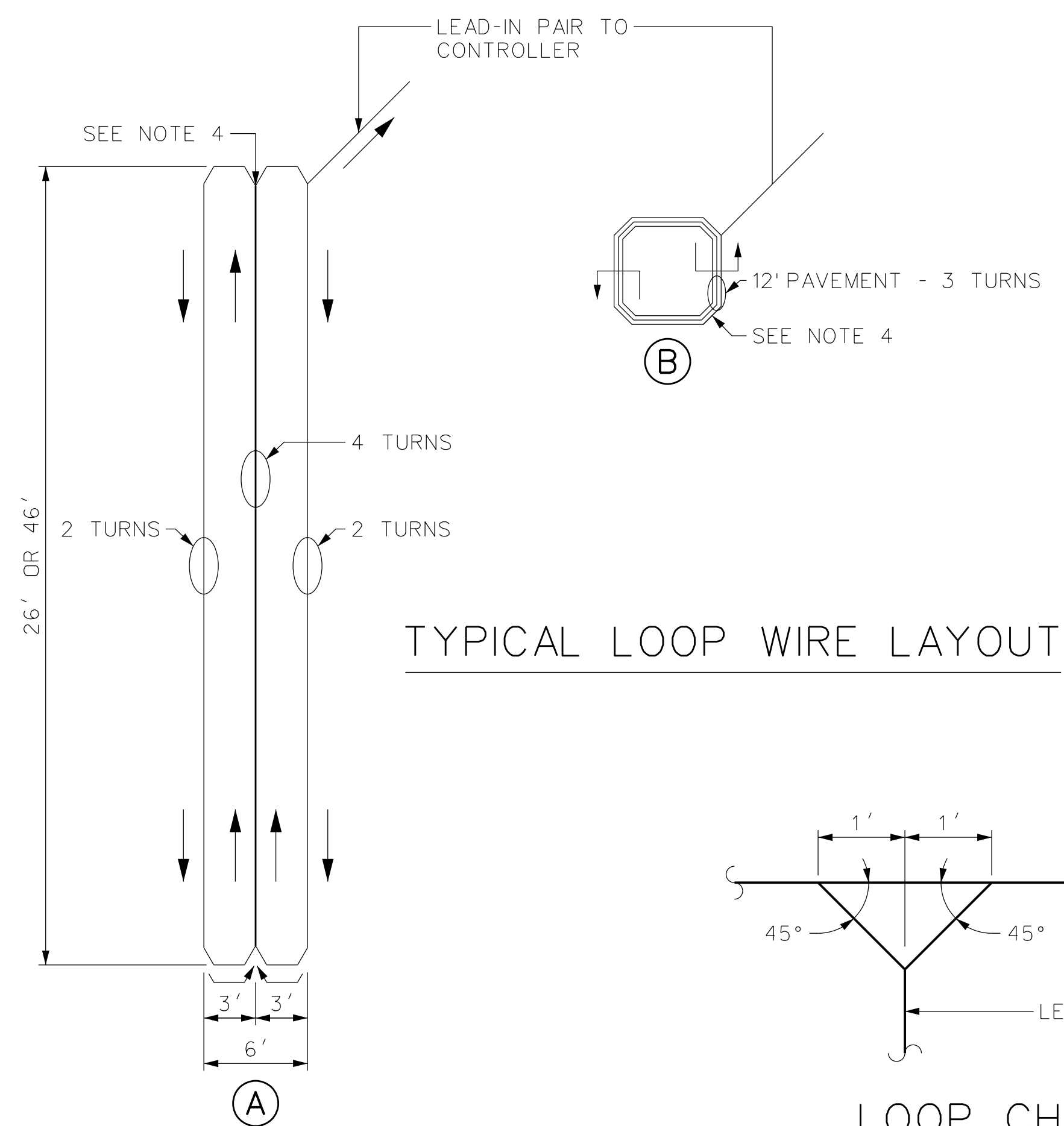

TYPICAL LOOP WIRE LAYOUT

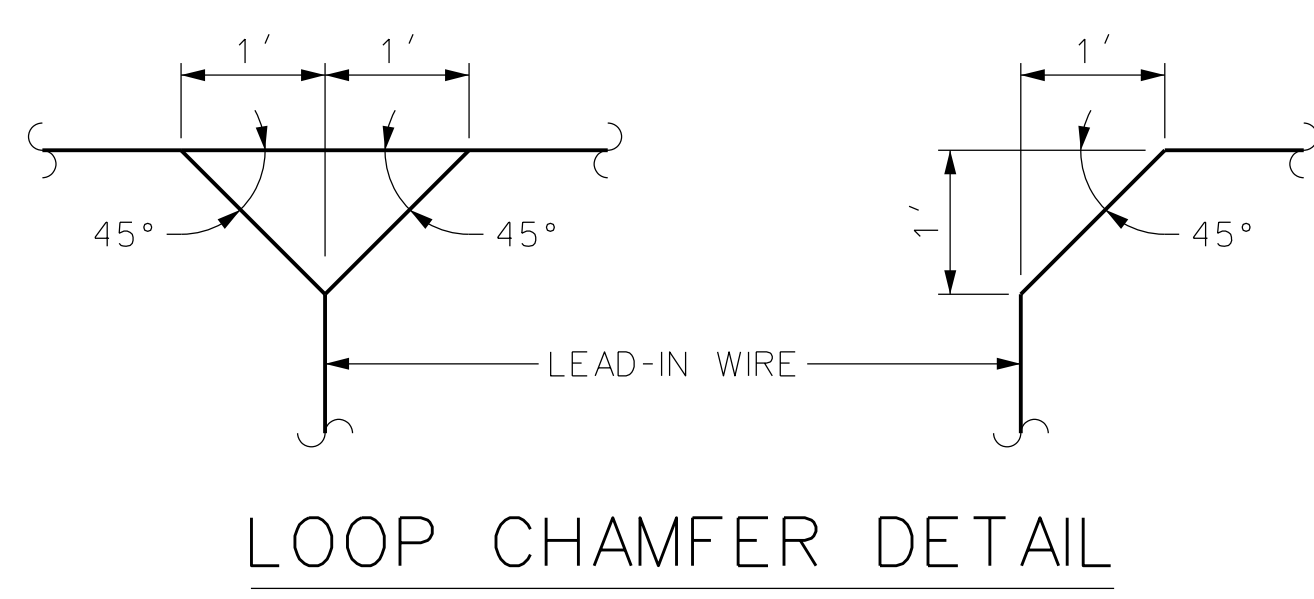

LOOP CHAMFER DETAIL

ADVANCE LOOP LOCATION

| 85TH PERCENTILE SPEED | ADVANCE LOOP "A" BACK EDGE (FROM STOP BAR) | ADVANCE LOOP "B" BACK EDGE (FROM STOP BAR) |
|-----------------------|--|--|
| 40 MPH | 285 FEET | N/A |
| 45 MPH | 225 FEET | 355 FEET |
| 50 MPH | 225 FEET | 385 FEET |
| 55 MPH | 225 FEET | 435 FEET |
| | OR AS NOTED ON PLAN | OR AS NOTED ON PLAN |

USE ADVANCE LOOPS FOR RURAL AREAS ON ROADS WITH SPEED LIMIT OF 55 MPH OR HIGHER, UNLESS OTHERWISE SPECIFIED BY COUNTY ENGINEER.

| NO. | DATE | REVISIONS | BY | APP. |
|--|------|----------------|----|--------------------|
| GENERAL NOTES: 1. THIS DRAWING IS NOT TO SCALE. 2. DESIGN, LAYOUT & DATA ON THIS SHEET ARE FOR ILLUSTRATION PURPOSE ONLY. | | | | |
| PALM BEACH COUNTY, FLORIDA TRAFFIC DIVISION SIGNAL TYPICAL | | | | |
| STOP BAR LOOPS AND ADVANCE LOOPS | | | | |
| SIGNATURE | | DATE | | |
| DRAWN BY | | SCALE | | ENGINEER OF RECORD |
| CHECKED BY | | N. T. S. | | CONTRACT NO. |
| DRAWING T-11 | | SHEET 24 OF 28 | | |

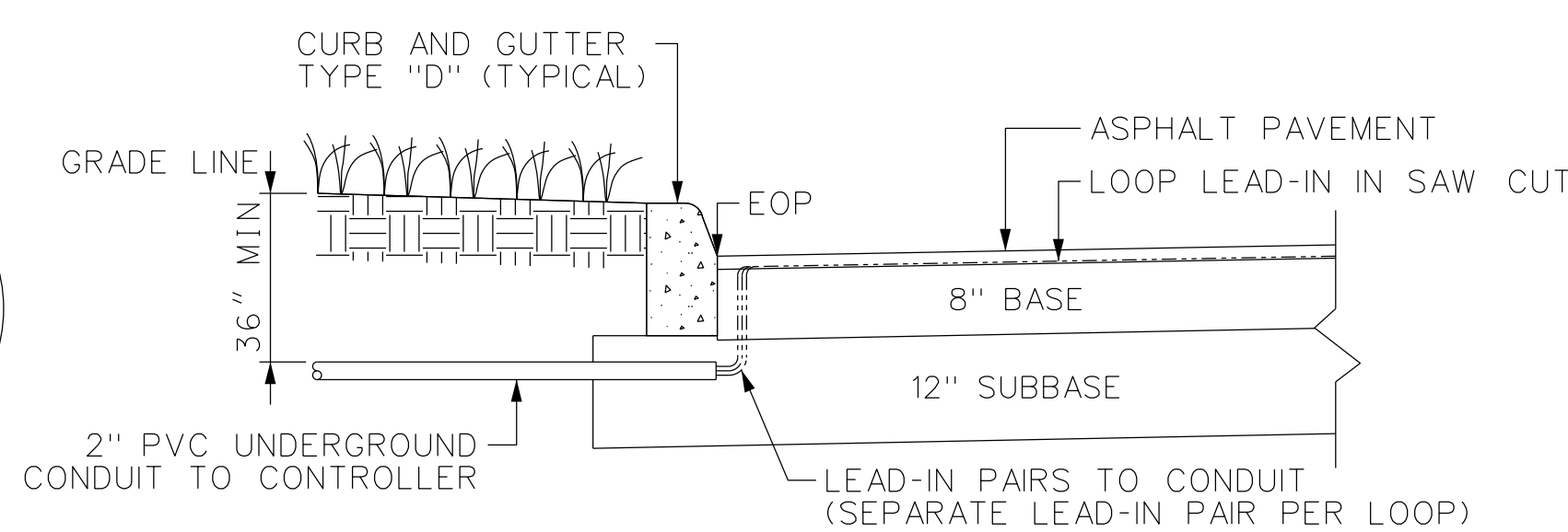
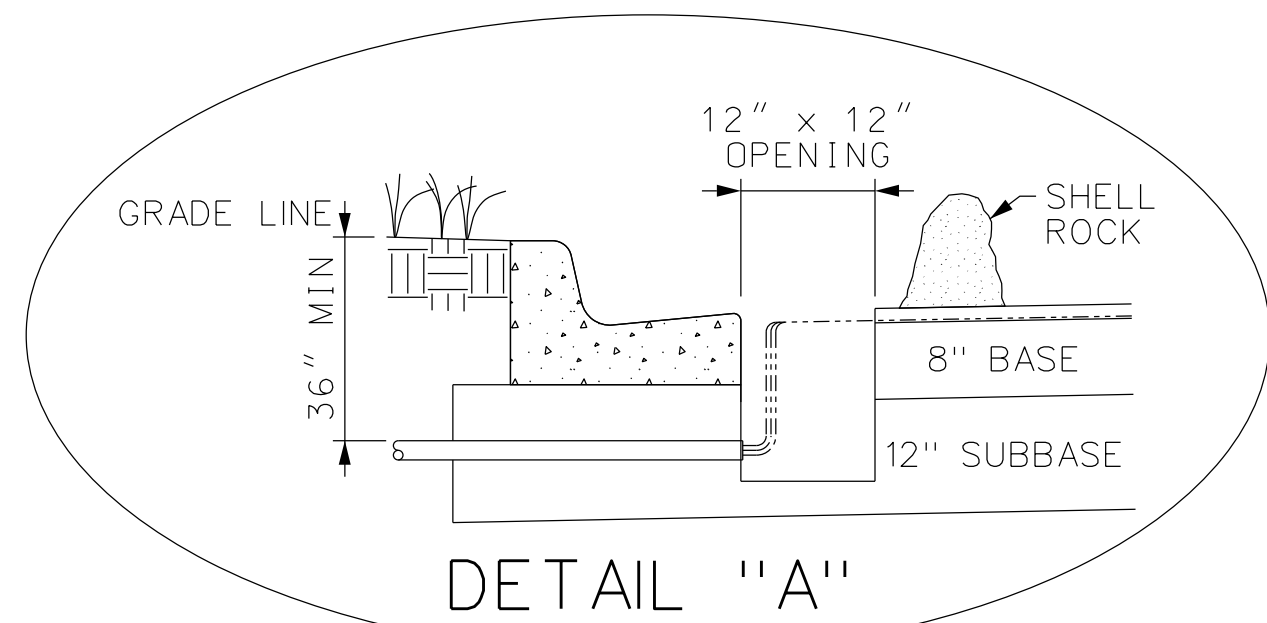
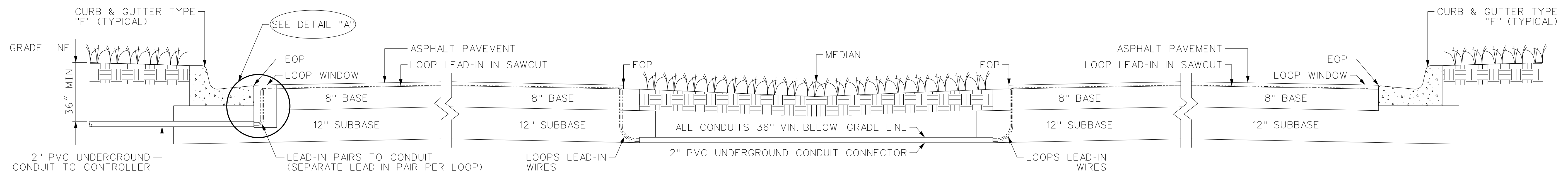

**LOOP LEAD-IN
INSTALLATION DETAIL**

1. 12" X 12" OPENING FOR LOOP LEAD-INS.
2. USE REMOVED SHELL ROCK TO REFILL THE HOLE, COMPACT SHELL ROCK WITH HAND TAMPER.
3. SEAL HOLE WITH EQUAL AMOUNT OF ASPHALT AS REMOVED (4" MINIMUM), CROWN ASPHALT 2" HIGH ABOVE HOLE.

NOTES:

1. LEAD-IN CABLE SHALL BE 18 AWG TINNED COPPER, TWO CONDUCTOR POLYETHYLENE INSULATED, TWISTED SHIELDED PAIR, STRANDED TINNED COPPER DRAIN WIRE, PVC CHROME VINYL POLYVINYL CHLORIDE JACKET, 300V.
2. LOOP WIRE SHALL BE 14 AWG XHHW STRANDED COPPER.
3. LOOPS AND LEAD-INS SHALL ONLY BE SPLICED IN PULL BOXES. LOOP WIRES MUST BE TWISTED FROM HEAD OF LOOP AND RUN TO PULL BOX.

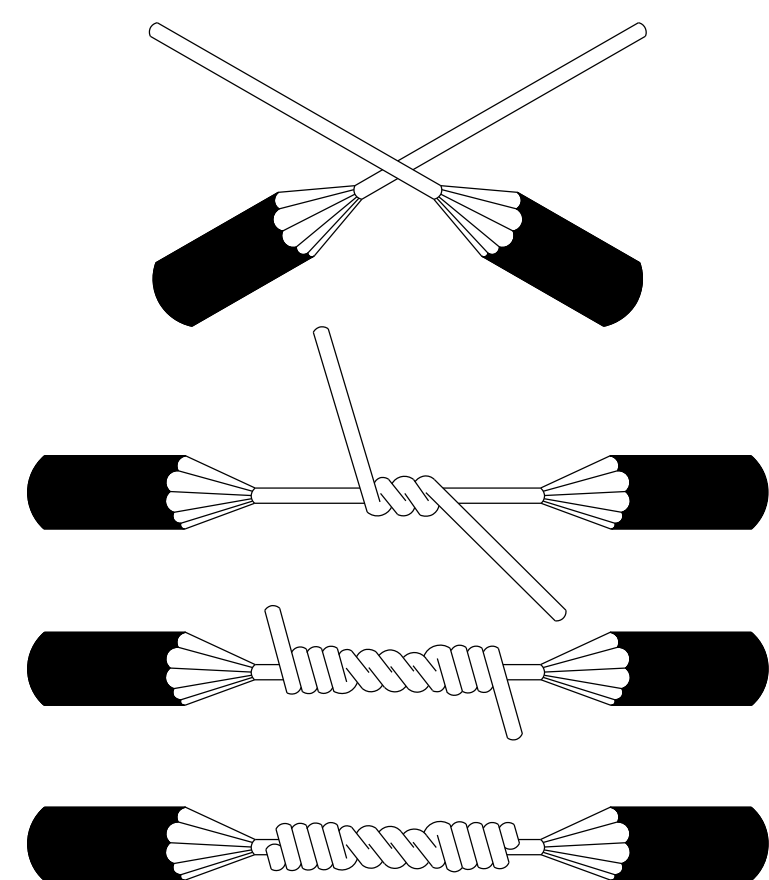

WESTERN UNION SPLICE * *

USE WESTERN UNION SPLICE METHOD FOR SPLICING AS DESCRIBED BELOW.

STEP 1:
PREPARE THE WIRES FOR SPLICING. ENOUGH INSULATION IS REMOVED TO MAKE THE SPLICE. THE CONDUCTOR IS CLEANED.

STEP 2:
BRING THE WIRES TO A CROSSED POSITION AND MAKE A LONG TWIST OR BEND IN EACH WIRE.

STEP 3:
WRAP ONE END OF THE WIRE AND THEN THE OTHER END FOUR OR FIVE TIMES AROUND THE STRAIGHT PORTION OF EACH WIRE.

STEP 4:
PRESS THE ENDS OF THE WIRES DOWN AS CLOSE AS POSSIBLE TO THE STRAIGHT PORTION OF THE WIRE. THIS PREVENTS THE SHARP ENDS FROM PUNCTURING THE TAPE COVERING THAT IS WRAPPED OVER THE SPLICE.

STEP 5:
SOLDER CONNECTION WITH NEW 60/40 ROSIN CORE SOLDER.

STEP 6:
AFTER SOLDER IS APPLIED, WRAP EACH SPLICE SEPARATELY WITH ELECTRICAL TAPE AND COVER WITH LIQUID ELECTRICAL COATING, 3M SCOTCHKOTE OR EQUIVALENT. THEN RE-TAPE AND RE-SEAL WITH ELECTRICAL COATING.

* * WESTERN UNION SPLICE AND STAGGERING SPLICE DETAILS ADAPTED FROM ELECTRICAL ENGINEERING TRAINING SERIES. WEB SITE: [HTTP://TPUB.COM/NEETS/](http://TPUB.COM/NEETS/) (JAN. 2010)
TAPE EACH CONDUCTOR SPLICE INDIVIDUALLY, THEN TAPE PAIR TOGETHER. SCOTCHKOTE SPLICE, TAPE AND SCOTCHKOTE AGAIN.

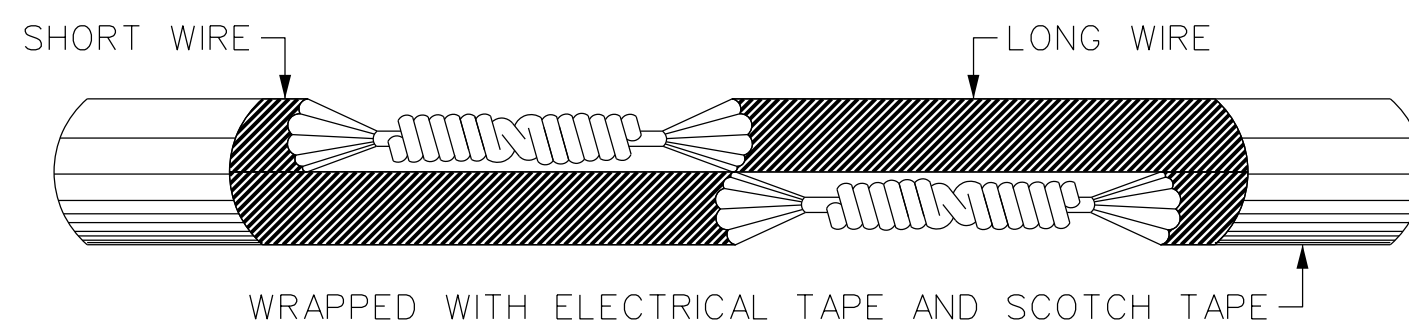

STAGGERING SPLICES * *

JOINING SMALL MULTICONDUCTOR CABLES OFTEN PRESENTS A PROBLEM. EACH CONDUCTOR MUST BE SPLICED AND TAPED. IF THE SPLICES ARE DIRECTLY OPPOSITE EACH OTHER, THE OVERALL SIZE OF THE JOINT BECOMES LARGE AND BULKY. A SMOOTHER AND LESS BULKY JOINT CAN BE MADE BY STAGGERING THE SPLICES.

FIGURE ABOVE SHOWS HOW A TWO-CONDUCTOR CABLE IS JOINED TO A SIMILAR SIZE CABLE BY USING A WESTERN UNION SPLICE AND BY STAGGERING THE SPLICES. CARE SHOULD BE TAKEN TO ENSURE THAT A SHORT WIRE FROM ONE SIDE OF THE CABLE IS SPLICED TO A LONG WIRE, FROM THE OTHER SIDE OF THE CABLE. THE SHARP ENDS ARE THEN CLAMPED FIRMLY DOWN ON THE CONDUCTOR. THE FIGURE SHOWS A WESTERN UNION SPLICE, BUT THE OTHER TYPES OF SPLICES WORK JUST AS WELL.

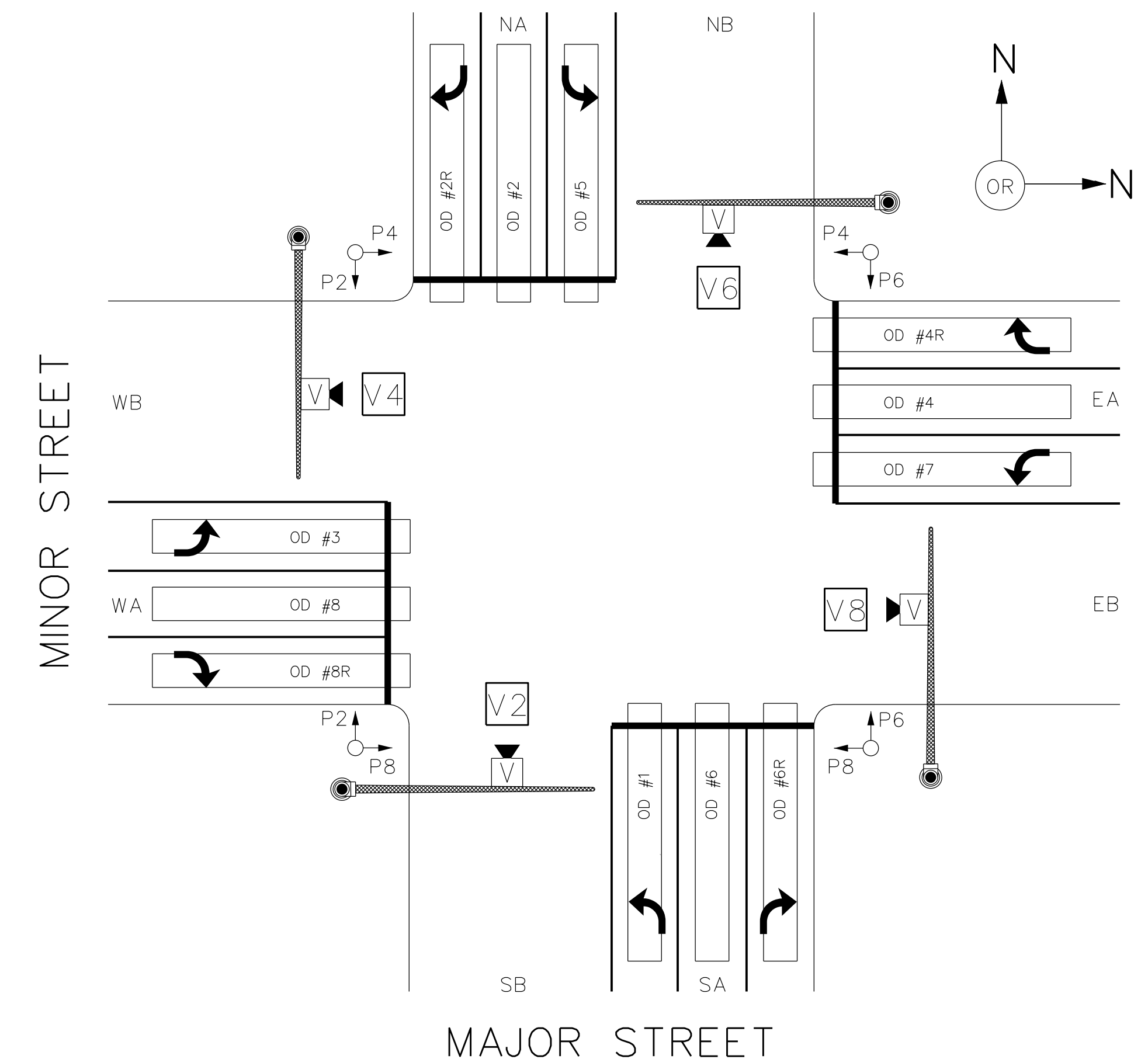

OD # = OPTICAL DETECTION ZONE
(SIZE EQUIVALENT TO SIZE OF LOOPS. SIZE MAY VARY AS PER PLAN.)

VIDEO DETECTION ZONE DETAIL

GENERAL NOTES:

1. THIS DRAWING IS NOT TO SCALE.
2. DESIGN, LAYOUT & DATA ON THIS SHEET ARE FOR ILLUSTRATION PURPOSE ONLY.

PALM BEACH COUNTY, FLORIDA
TRAFFIC DIVISION

SIGNAL TYPICAL

INDUCTANCE LOOP DETECTOR SPLICING
DETAIL, LOOP LEAD-IN DETAIL, VIDEO
DETECTION ZONE DETAIL

| | | | |
|------------|------|-----------------|--------------------|
| SIGNATURE | DATE | FATMEH N. JAFAR | ENGINEER OF RECORD |
| DRAWN BY | DATE | SCALE | CONTRACT NO. |
| CHECKED BY | | N. T. S. | |

| NO. | DATE | REVISIONS | BY | APP. |
|-----|------|-----------|----|------|
| | | | | |

5 - LANE ROADWAY SECTION

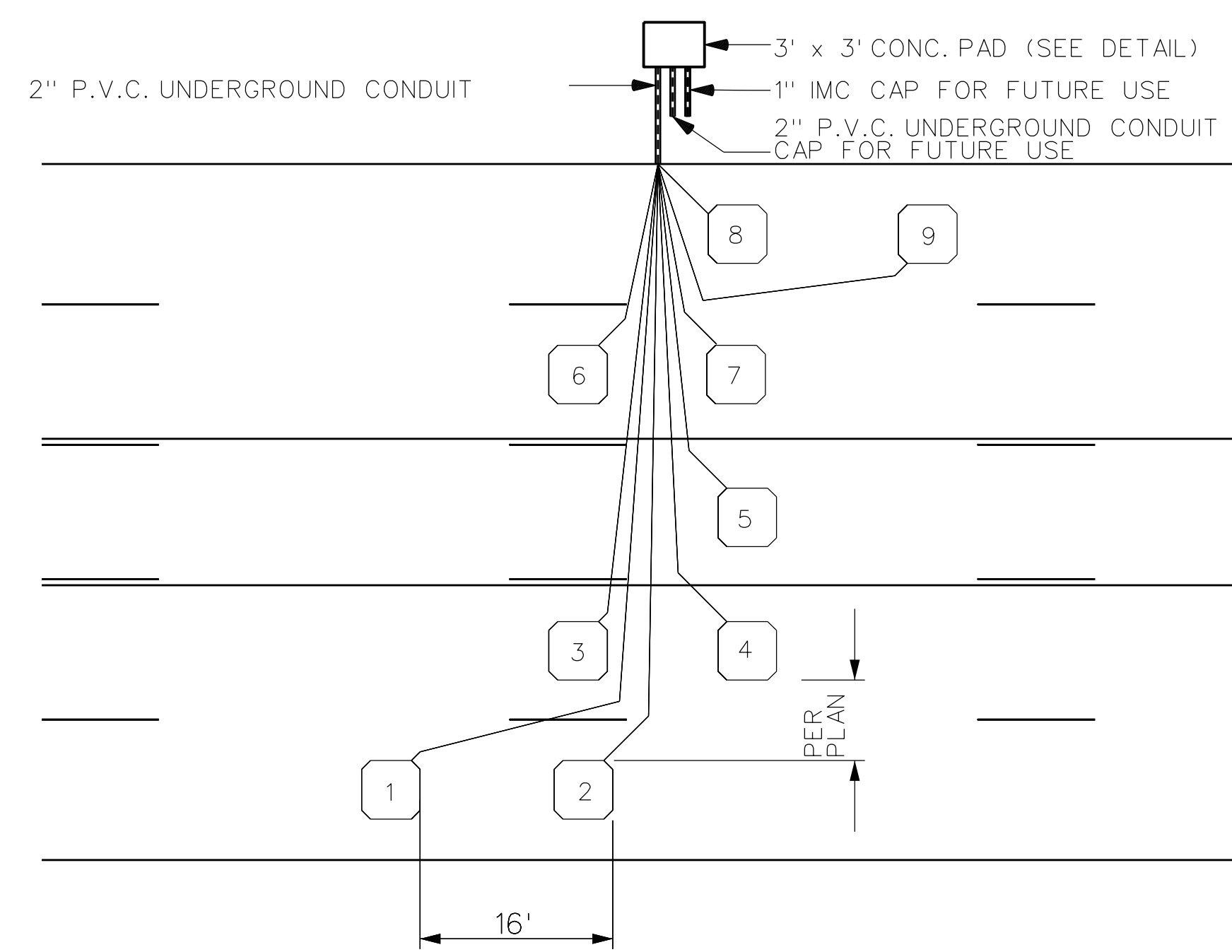

6'X6' LOOP DETAIL

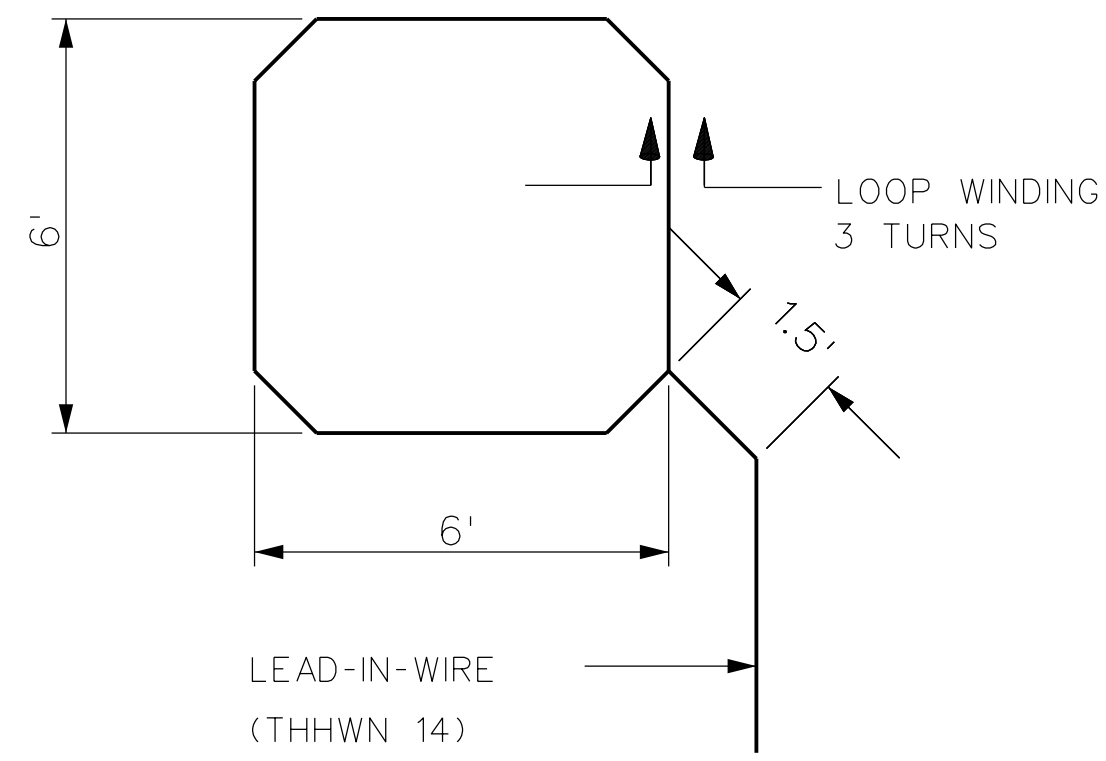

DESIGN NOTES:

1. ALL LOOPS ARE TO BE 6' X 6', WIRE = THHN 14, THREE TURNS. (LOOP SIZE MAY VARY AS PER PLAN.)
2. LEAD-IN SHALL EXTEND 18" AT A 45° ANGLE
3. SPACE LOOPS 16' (LEADING EDGE TO LEADING EDGE) APART.
4. POSITION LOOPS TO BE IN CENTER OF LANE.
5. LOOP LEAD-INS ARE TO BE LABELED AS TO LANE & DIRECTION.
6. EXACT LOCATION OF CONCRETE PAD & BOX TO BE DETERMINED BY THE TRAFFIC DIVISION OR AS PLAN.
7. CABINET TO BE PROVIDED BY THE TRAFFIC DIVISION UNLESS OTHERWISE INDICATED.
8. ONE 2" PVC SCH. 40 AND ONE 1" IMC CONDUIT STUBED-OUT AND CAPPED ARE FOR FUTURE USE.
9. AS PER FLORIDA DEPARTMENT OF TRANSPORTATION STANDARD SPECIFICATION FOR ROAD AND BRIDGE CONSTRUCTION 2022 EDITION, SECTION 660, INDUCTIVE LOOPS AND DESIGN STANDARD PLANS 2022-2023 (OR LATER VERSION) INDEX 660-001.

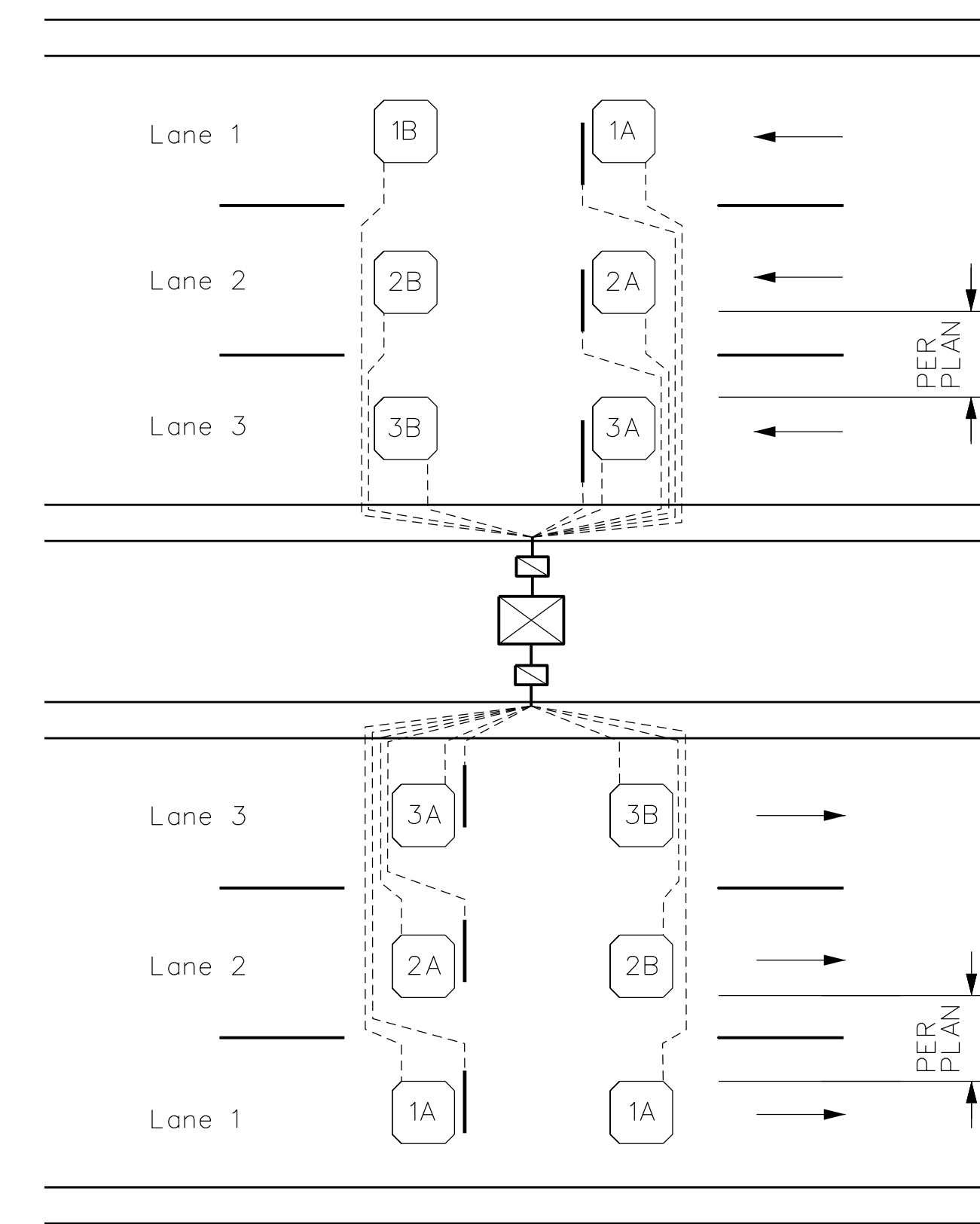

DIVIDED ROADWAY SECTION

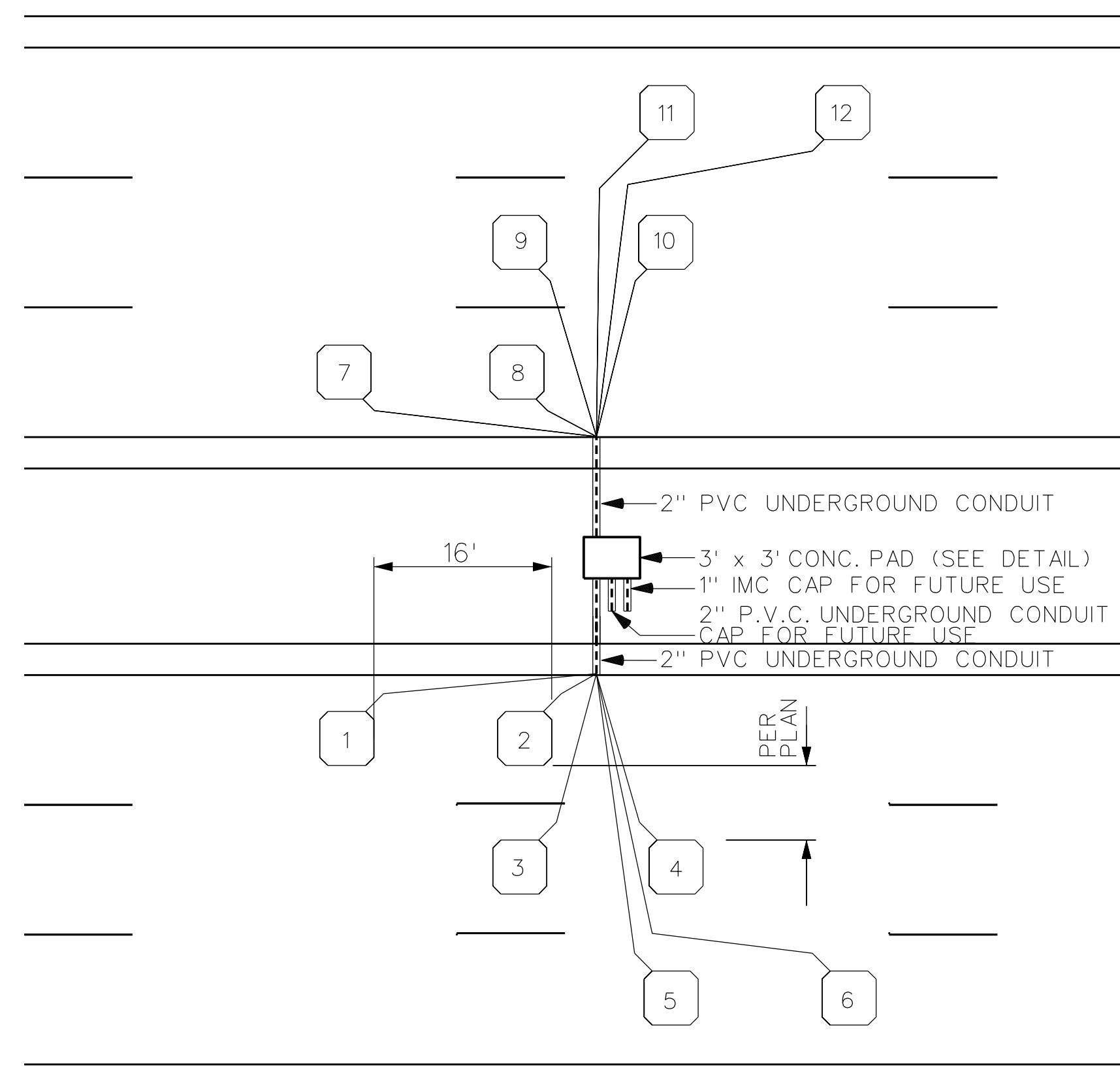

DIVIDED ROADWAY SECTION

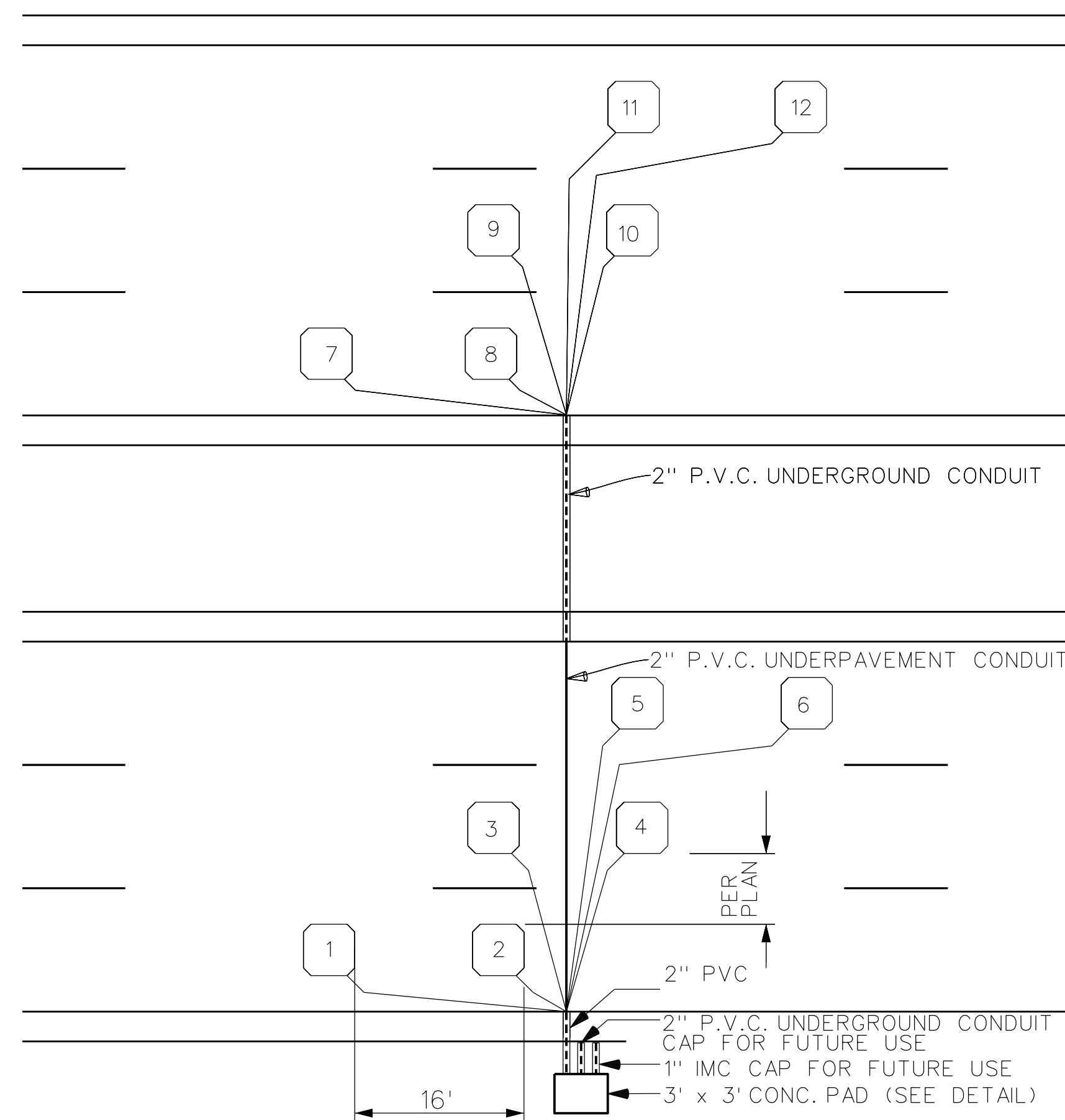

SIX LANE, DIVIDED - TWO WAY

GENERAL NOTES:

1. THIS DRAWING IS NOT TO SCALE.
2. DESIGN, LAYOUT & DATA ON THIS SHEET ARE FOR ILLUSTRATION PURPOSE ONLY.

PALM BEACH COUNTY, FLORIDA
TRAFFIC DIVISION
SIGNAL TYPICAL

PERMANENT COUNT STATION
LOOP DETAIL

| | | | | |
|------------|------|------|-----------------|--------------------|
| SIGNATURE | NAME | DATE | FATMEH N. JAFAR | ENGINEER OF RECORD |
| DRAWN BY | | | SCALE | CONTRACT NO. |
| CHECKED BY | | | N. T. S. | |

| NO. | DATE | REVISIONS | BY | APP. |
|-----|------|-----------|----|------|
| | | | | |

THIS SHEET IS INTENTIONALLY LEFT BLANK

GENERAL NOTES:
1. THIS DRAWING IS NOT TO SCALE.
2. DESIGN, LAYOUT & DATA ON THIS SHEET
ARE FOR ILLUSTRATION PURPOSE ONLY.

PALM BEACH COUNTY, FLORIDA
TRAFFIC DIVISION
SIGNAL TYPICAL

BLANK

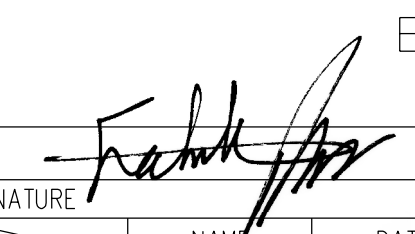
| | | | | |
|------------|---|------|---------------------------------------|--------------|
| SIGNATURE |  | DATE | FATMEH N. JAFAR ENGINEER OF RECORD | |
| DRAWN BY | NAME | DATE | SCALE | CONTRACT NO. |
| CHECKED BY | | | N. T. S. | |

| NO. | DATE | REVISIONS | BY | APP. |
|-----|------|-----------|----|------|
| | | | | |

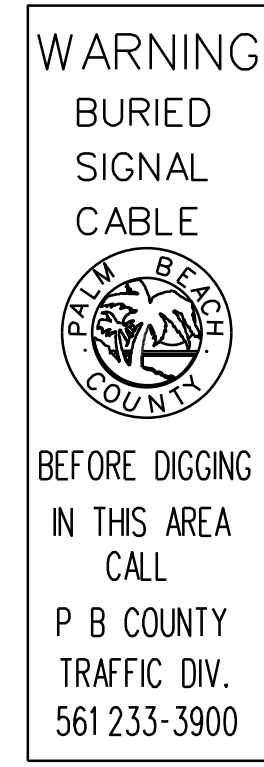

INSTALL ROUTE MARKER AT EVERY OTHER PULL BOX WHERE PULL BOXES ARE IN TURF AREAS AND ON BOTH SIDES OF CANAL CROSSING. DO NOT INSTALL MARKERS IF THE PULL BOXES ARE IN OR NEXT TO SIDEWALK. COST OF ROUTE MARKER SHALL BE INCLUDED IN COST OF CONDUITS.

Store 200' of slack Fiber Optic Cable in 30x48x24" large pull boxes, store 20' in 17x30x24" pull boxes, and store 200' on each side of FO splice enclosure.

NOTE: SIGNAL pull boxes (for signal cables) shall be 17x30x12" deep, not 24" deep. Refer to PBC Signal Typical.

LABELS ARE SUPPLIED BY PALM BEACH COUNTY TRAFFIC. FOR LABELS CALL: 561-681-4326 (SEE NOTE NO. 6)

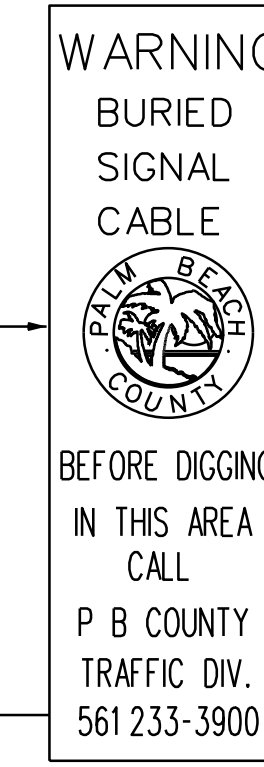

30x48" Lid size x24" deep LARGE PULL BOX

18" WIDE X 6" THICK CONCRETE APRON SLOPE 1/4" PER 1'

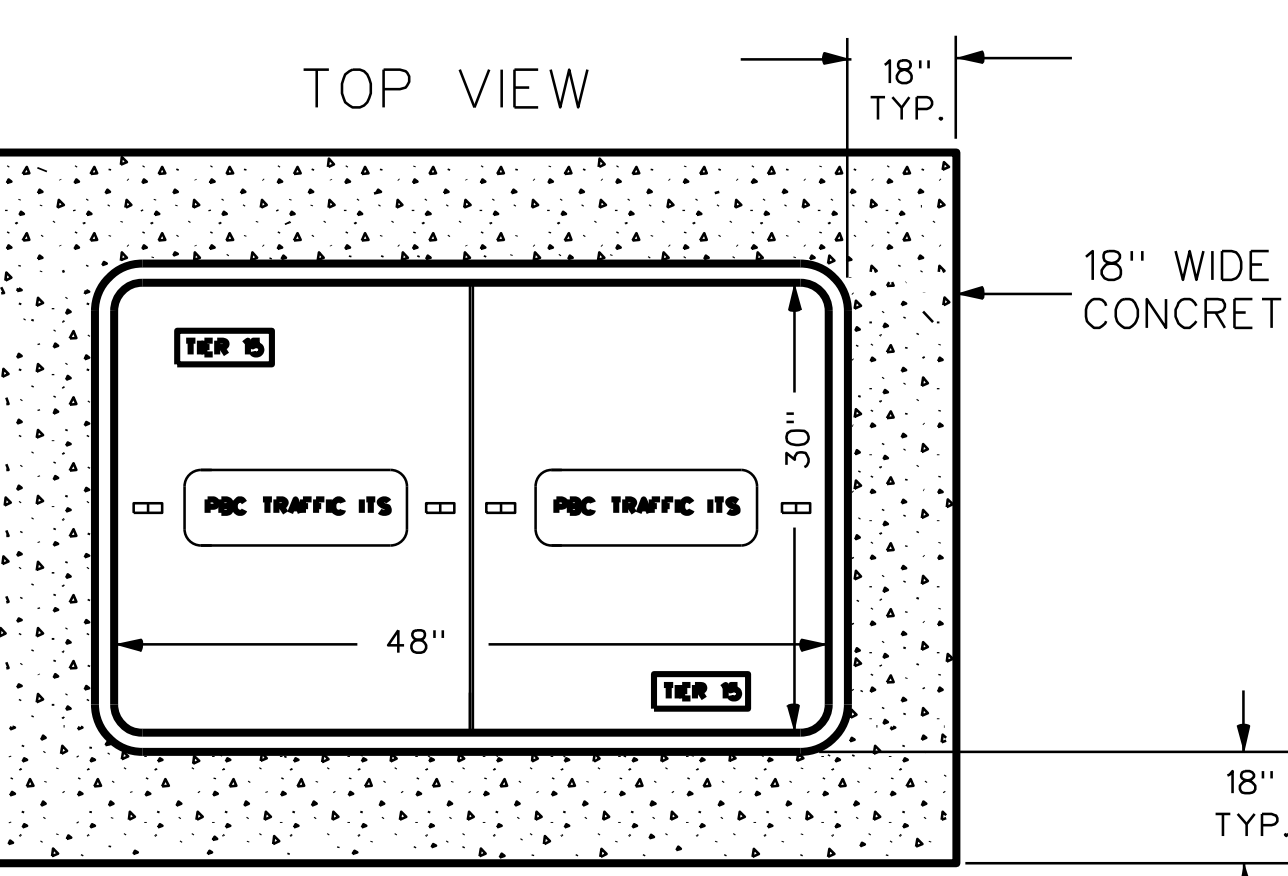
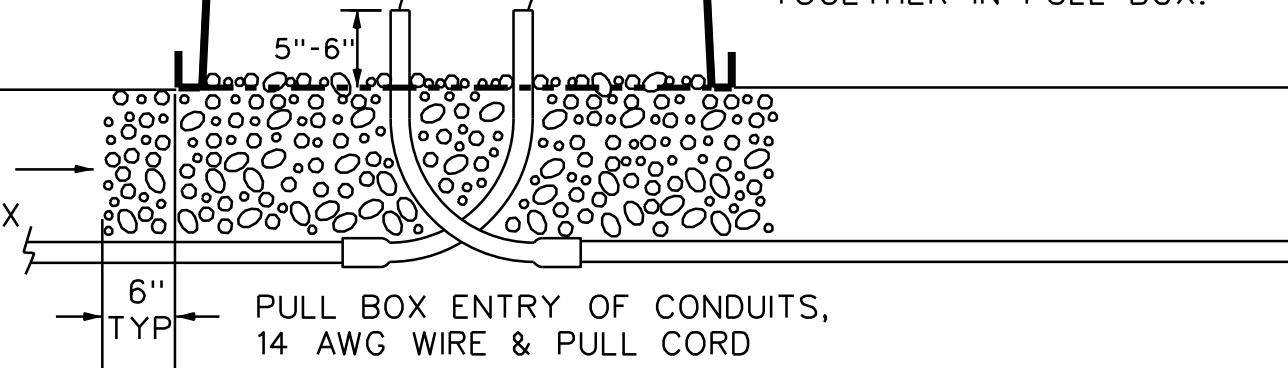
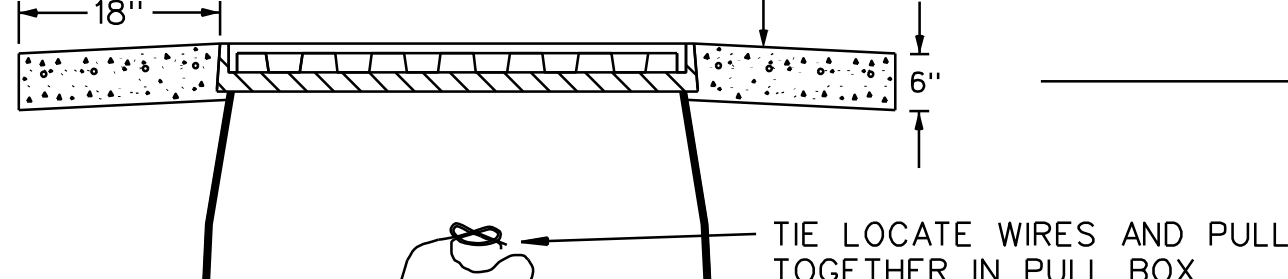

PULL BOX MATERIAL: FIBERGLASS REINFORCED POLYMER CONCRETE
LOAD SPECIFICATION: MIN. TIER 15 (20K-22K) EXCEPT IN ROADWAY USE AASHTO H-20.
LID STAMPED: "PBC TRAFFIC ITS". LID TYPE: TWO PANEL WITH TWO PULL SLOTS EACH

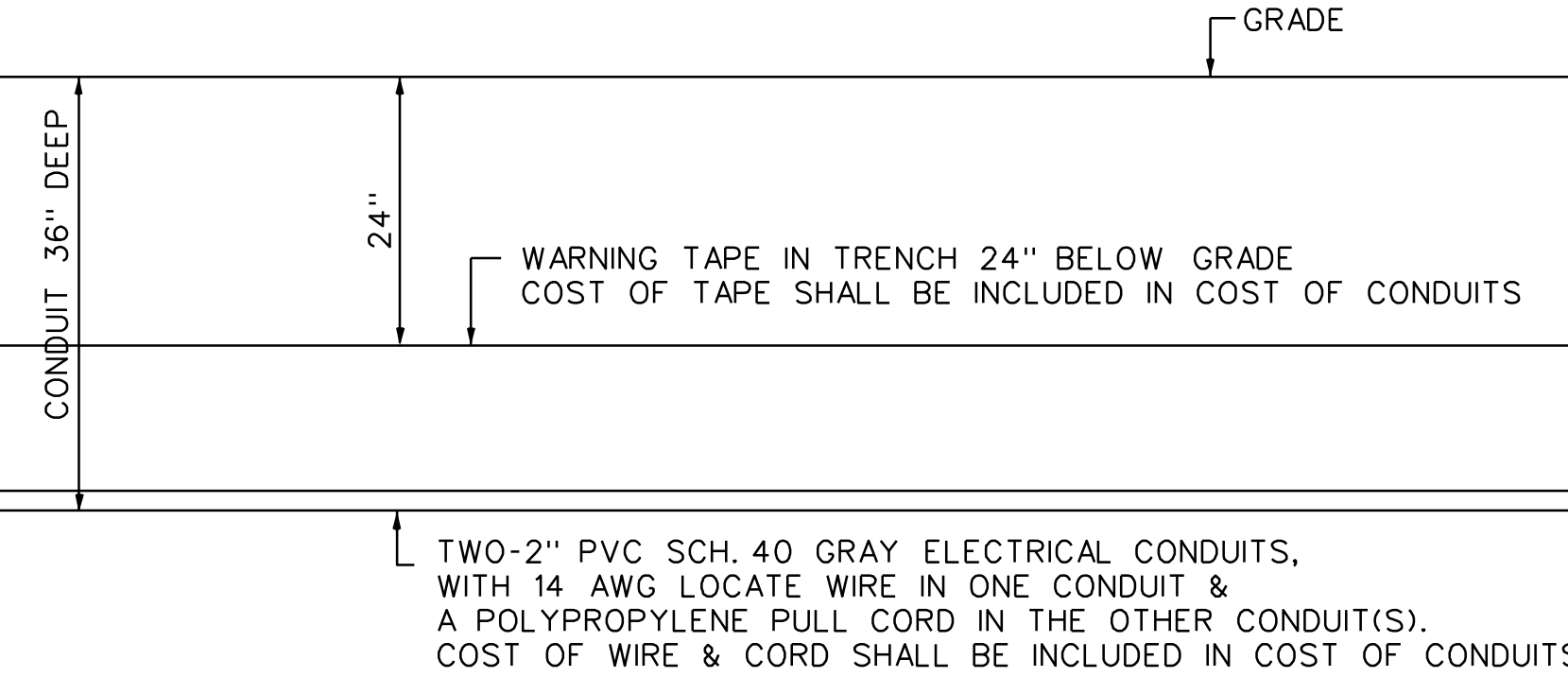

17x30 Lid size x24" Deep Typ. PULL BOX

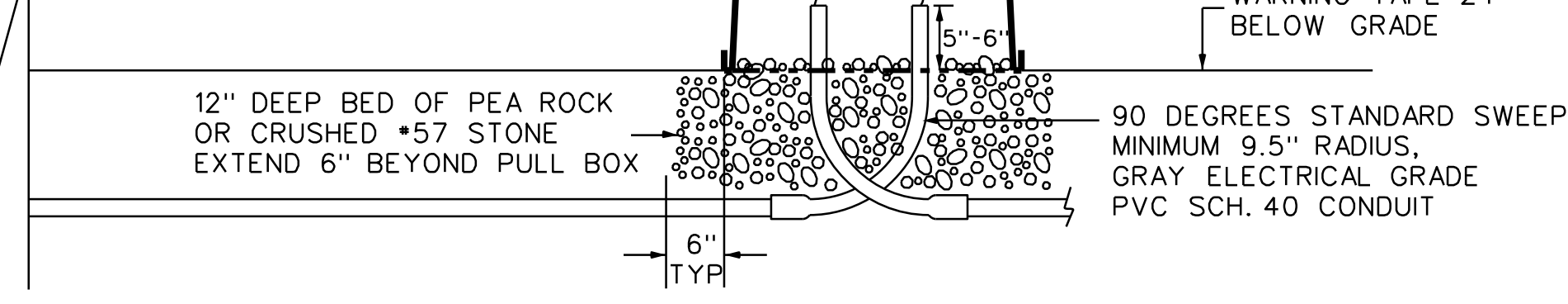
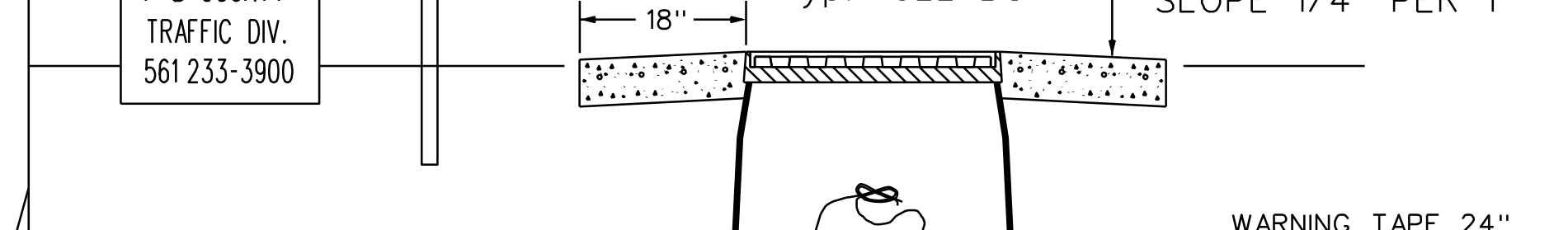

INSTALL A TYPICAL PULL BOXES (17X30X24" DEEP) EVERY 500' (+/-). INSTALL A LARGE PULL BOX (30X48X24" DEEP) EVERY 2000' (+/-) AND AT EACH SIGNALIZED INTERSECTION, OR AS SHOWN ON THE PLANS. WHERE A LARGE PULL BOX IS INSTALLED, IT TAKES THE PLACE OF THE TYPICAL PULL BOX.

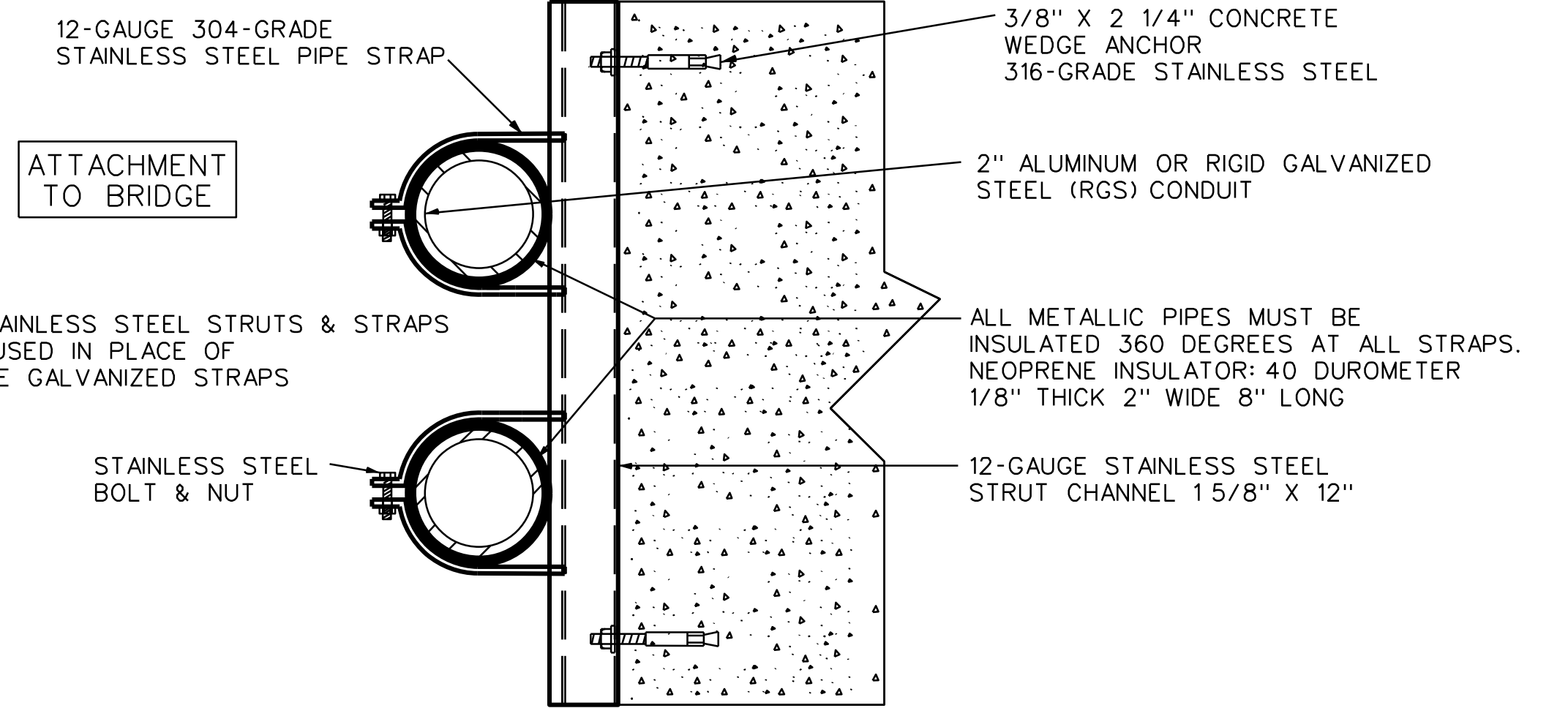
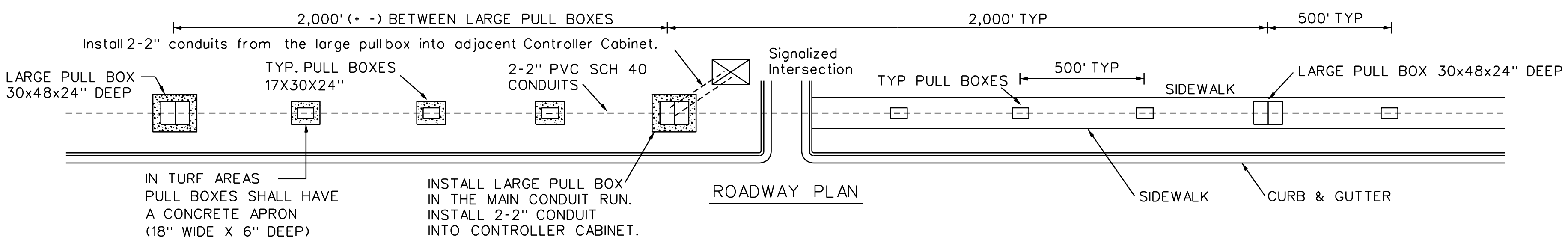

- NOTES:
1. Typical (T-14) for applications not covered in this typical the contractor shall refer to the FDOT Standards Specifications 630 for Road and Bridge Construction.
 2. Pull Boxes and Lids in sidewalks and turf areas shall be a minimum TIER 15 (20K-22K). In vehicular traffic areas (in the roadway) pull boxes shall be AASHTO H-20. Pull Box Lid shall be stamped "PBC TRAFFIC ITS". Large Pull Box Lids (30x48") shall have two panels with two pulling slots in each panel.
 3. Underground Conduits and Sweeps shall be gray-electrical grade 2" PVC SCH 40 or HDPE SDR 11. Install conduits 36" below grade. Ends of conduit shall be sealed with water resistance duct seal.
 4. One run of conduit between pull boxes shall not contain more than four (4) 90 degree bends (360 degrees) including pull box bends.
 5. Signalized Intersections, install two-2" PVC SCH. 40 conduits from the large pull box into the traffic controller cabinet.
 6. Locate Wire, install a 14 AWG insulated THWN strand copper wire (locate wire) in one conduit and a polypropylene pull cord in the other conduit(s). The locate wire, pull cord, warning tape, and guide post shall be included in the cost of the conduits.
 7. Concrete Apron, all pull boxes shall be provided with concrete aprons when not located within sidewalk. Aprons shall be 18" wide x 6" thick sloped 1/4" per 1' away from pull box. Apron shall be Min. 2,500 PSI non structural Class I concrete. The cost of the apron is to be included in the cost to furnish and install pull box.
 8. Pedestrian Ramp, pull box shall not be placed in a pedestrian ramp or slopped area of a pedestrian ramp.
 9. Conduits in Pull Box shall be extended up 5" to 6" from the bottom of the pull box.
 10. Bridge Attachment, when attaching conduits to bridge, wrap neoprene (rubber) gasket completely around galvanized or aluminum IMC conduit at each pipe strap to insulate conduit from pipe strap. Size of neoprene (rubber) insulator: 1/8" thick x 2" wide x 8" long.
 11. Warning Tape: 3" wide, 6 mil thick, intended for burial and use as an underground utility warning notice, marked "CAUTION BURIED FIBER OPTIC". Tape shall be orange with black 2" high block letters on non color fading material. The marking tape shall be buried 24" below grade in the conduit trench from pull box to pull box. Cost included in cost of conduits.
 12. Warning Labels, Palm Beach County Traffic Engineering, 2300 N Jog Rd, Tel.: 561-681-4326 will supply the Contractor with two warning label for each route marker.
 13. PBC Engineer may request two or more 2" conduits as needed.

| NO. | DATE | REVISIONS | BY | APP. |
|-----|----------|--|--------|------|
| 1 | 8-21-09 | Changed pull box for fiber optic cable from 12" deep to 24" deep. | H.E.R. | |
| 2 | 11-2-09 | Changed Bridge Attachment from 1-Hole 'C' Strap to 2-Hole Strap. | H.E.R. | |
| 3 | 11-27-12 | Revised Bridge Attachment Per PBC ROAD & BRIDGE Min. Requirements. | H.E.R. | |
| 4 | 10-25-13 | Remove wire mesh for apron, Change PSI to 2500 non structural class I. | H.E.R. | |
| 5 | 3-27-15 | Locate wire, pull cord, warning tape, & guide post included in cost of cond. | H.E.R. | |
| 6 | 12-15-15 | All ITS Fiber Optic Pull Box Lids shall be stamped "PBC TRAFFIC ITS". | H.E.R. | |
| 7 | 9-28-16 | Pull Box in sidewalk or turf TIER 15 (20K-22K) in roadway-AASHTO H-20. | H.E.R. | |
| 8 | 8-3-17 | Changed Warning Tape from 12" to 24" below grade. | H.E.R. | |
| 9 | 12-10-18 | Store 200' Slack FO Cable on each side of a FO splice enclosure. | H.E.R. | |
| 10 | 9-1-20 | Conduit sweeps shall be 5" to 6" above bottom of pull box/pea rock. | H.E.R. | |

PALM BEACH COUNTY, FLORIDA
TRAFFIC DIVISION

UNDERGROUND/UNDER PAVEMENT ITS TRAFFIC FACILITIES

TYPICAL: TWO CONDUITS WITH PULL BOXES, ROUTE MARKERS, WARNING TAPE, LOCATE WIRE & PULL CORD

12-07-20
DATE
Rosam Awwad
REGISTERED ENGINEER

| | | | | |
|------------|----------|---------|-------|--------------|
| SIGNATURE | NAME | DATE | SCALE | CONTRACT NO. |
| | H. E. R. | 4-23-97 | N.T.S | |
| CHECKED BY | R.A. | | | |

T-14

SHEET 14 OF 14 SHEETS